

# Gold Cello Digital Servo Drive Installation Guide EtherCAT and CAN



# Notice

This guide is delivered subject to the following conditions and restrictions:

- This guide contains proprietary information belonging to Elmo Motion Control Ltd. Such information is supplied solely for the purpose of assisting users of the Gold Cello servo drive in its installation.
- The text and graphics included in this manual are for the purpose of illustration and reference only. The specifications on which they are based are subject to change without notice.
- Information in this document is subject to change without notice.

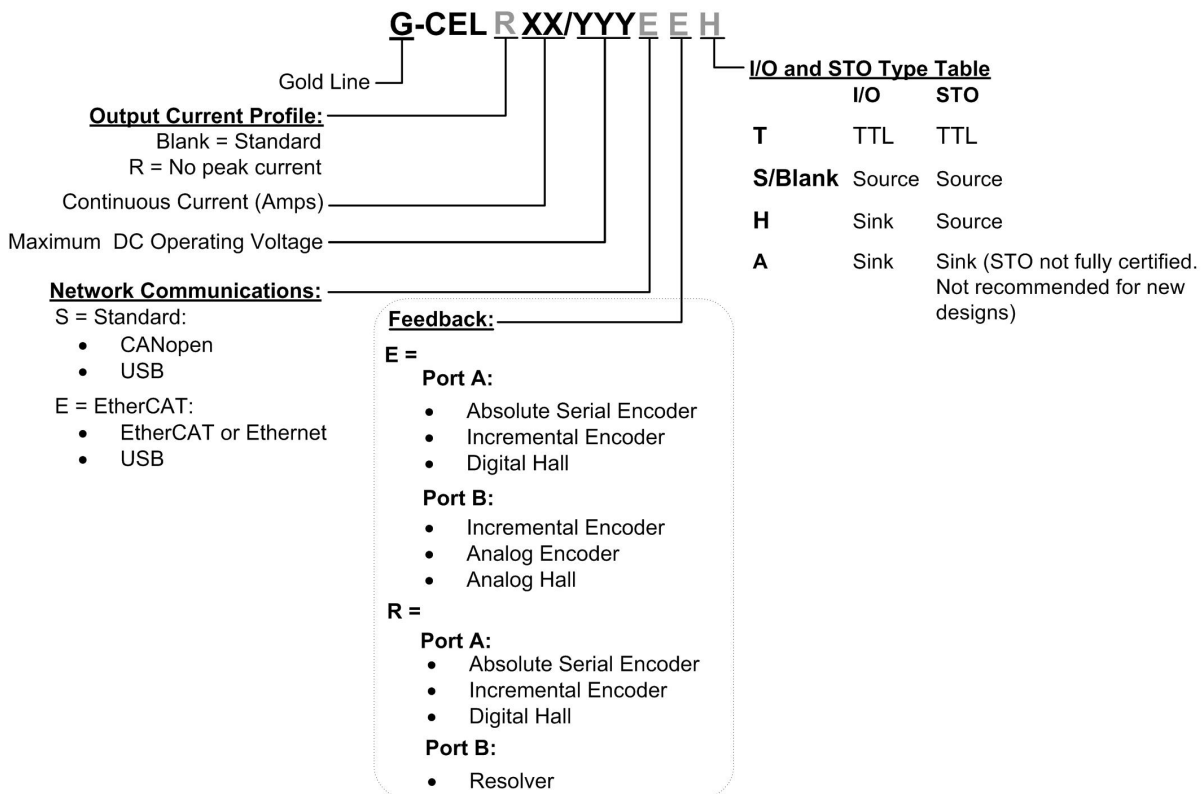
Document no. MAN-G-CELIG (Ver. 1.204)

Copyright © 2016

Elmo Motion Control Ltd.

All rights reserved.

## Catalog Number



## Revision History

Version	Date
Ver. 1.200	June 2014
Ver. 1.201	Aug 2014
Ver. 1.202	July 2015
Ver. 1.203	Oct 2015



- Chapter 1: This Installation Guide .....6**
- Chapter 2: Safety Information .....6**
  - 2.1. Warnings ..... 7
  - 2.2. Cautions..... 7
  - 2.3. CE Marking Conformance..... 7
  - 2.4. Warranty Information ..... 7
- Chapter 3: Product Description.....8**
  - 3.1.1. Accessories ..... 8
- Chapter 4: Technical Information.....9**
  - 4.1. Physical Specifications..... 9
  - 4.2. Technical Data ..... 9
    - 4.2.1. Auxiliary Supply ..... 10
    - 4.2.2. Product Features ..... 10
  - 4.3. Environmental Conditions..... 11
    - 4.3.1. Gold Line ..... 11
  - 4.4. Gold Line Standards..... 12
- Chapter 5: Installation.....13**
  - 5.1. Unpacking the Drive Components ..... 13
  - 5.2. Connectors and Indicators ..... 14
    - 5.2.1. EtherCAT Connector Types..... 14
    - 5.2.2. CAN Connector Types..... 15
  - 5.3. Mounting the Gold Cello ..... 17
  - 5.4. Gold Cello Connection Diagrams..... 18
- Chapter 6: Wiring.....20**
  - 6.1. Basic Recommendations ..... 22
    - 6.1.1. General ..... 22
    - 6.1.2. Feedback Cable Port A and Port B Connector ..... 23
    - 6.1.3. Feedback Cable Port C Connector ..... 24
    - 6.1.4. IO Cable Connector..... 24
    - 6.1.5. STO (Port C) Cable Connector..... 25
  - 6.2. Motor Power Connector Pinouts (J9)..... 26
  - 6.3. Main Power (J11)..... 28
  - 6.4. Auxiliary Power (J10)(optional) ..... 30
  - 6.5. Drive Status Indicator ..... 32
  - 6.6. Port A (P1) ..... 33
    - 6.6.1. Incremental Encoder ..... 34
    - 6.6.2. Hall Sensor ..... 34

# Table of Contents

MAN-G-CELIQ (Ver. 1.204)

6.6.3.	Absolute Serial Type Encoder .....	35
6.7.	Port B (P2).....	37
6.7.1.	Incremental Encoder .....	38
6.7.2.	Interpolated Analog Encoder .....	39
6.7.3.	Resolver .....	40
6.8.	Port C, Analog Input, and STO (P3).....	41
6.8.1.	Port C .....	43
6.8.2.	Analog Input .....	43
6.8.3.	STO.....	44
6.8.3.1.	Source Mode PLC Voltage Level .....	44
6.8.3.2.	TTL Mode TTL Voltage Level .....	44
6.8.3.3.	SINK Mode – PLC Voltage Level .....	45
6.9.	Digital Inputs and Outputs (P4) .....	46
6.9.1.	Digital Input and Output TTL Mode.....	48
6.9.2.	Digital Input and Output PLC Source Mode .....	50
6.9.3.	Digital Input and Output Sink Mode.....	52
6.10.	USB 2.0 (J22).....	54
6.11.	EtherCAT Communications Version .....	55
6.11.1.	EtherCAT IN/Ethernet Pinouts.....	55
6.11.2.	EtherCAT OUT .....	56
6.11.3.	EtherCAT Wiring .....	56
6.11.4.	EtherCAT Link Indicators .....	57
6.11.5.	EtherCAT Status Indicator .....	57
6.12.	CAN Communication Version .....	58
6.12.1.	CAN Wiring .....	59
6.13.	Powering Up .....	60
6.14.	Initializing the System .....	60
<b>Chapter 7:</b>	<b>Dimensions .....</b>	<b>61</b>



## ***Chapter 1: This Installation Guide***

This installation Guide details the technical data, pinouts, and power connectivity of the Gold Cello. For a comprehensive detailed description of the functions refer to the MAN-G-Panel Mounted Drives Hardware manual which describes Panel Mounted products.

## ***Chapter 2: Safety Information***

In order to achieve the optimum, safe operation of the Gold Cello, it is imperative that you implement the safety procedures included in this installation guide. This information is provided to protect you and to keep your work area safe when operating the Gold Cello and accompanying equipment.

**Please read this chapter carefully before you begin the installation process.**

Before you start, ensure that all system components are connected to earth ground. Electrical safety is provided through a low-resistance earth connection.

Only qualified personnel may install, adjust, maintain and repair the servo drive. A qualified person has the knowledge and authorization to perform tasks such as transporting, assembling, installing, commissioning and operating motors.

The Gold Cello contains electrostatic-sensitive components that can be damaged if handled incorrectly. To prevent any electrostatic damage, avoid contact with highly insulating materials, such as plastic film and synthetic fabrics. Place the product on a conductive surface and ground yourself in order to discharge any possible static electricity build-up.

To avoid any potential hazards that may cause severe personal injury or damage to the product during operation, keep all covers and cabinet doors shut.

The following safety symbols are used in this and all Elmo Motion Control manuals:



**Warning:**

**This information is needed to avoid a safety hazard, which might cause bodily injury or death as a result of incorrect operation.**



**Caution:**

This information is necessary to prevent bodily injury, damage to the product or to other equipment.



**Important:**

Identifies information that is critical for successful application and understanding of the product.



## 2.1. Warnings

- To avoid electric arcing and hazards to personnel and electrical contacts, never connect/disconnect the servo drive while the power source is on.
- Power cables can carry a high voltage, even when the motor is not in motion. Disconnect the Gold Cello from all voltage sources before servicing.
- The high voltage products within the Gold Line range contain grounding conduits for electric current protection. Any disruption to these conduits may cause the instrument to become hot (live) and dangerous.
- After shutting off the power and removing the power source from your equipment, wait at least 1 minute before touching or disconnecting parts of the equipment that are normally loaded with electrical charges (such as capacitors or contacts). Measuring the electrical contact points with a meter, before touching the equipment, is recommended.



## 2.2. Cautions

- The maximum DC power supply connected to the instrument must comply with the parameters outlined in this guide.
- When connecting the Gold Cello to an approved isolated auxiliary power supply, connect it through a line that is separated from hazardous live voltages using reinforced or double insulation in accordance with approved safety standards.
- Before switching on the Gold Cello, verify that all safety precautions have been observed and that the installation procedures in this manual have been followed.
- Make sure that the Safe Torque Off is operational

## 2.3. CE Marking Conformance

The Gold Cello is intended for incorporation in a machine or end product. The actual end product must comply with all safety aspects of the relevant requirements of the European Safety of Machinery Directive 2006/42/EC as amended, and with those of the most recent versions of standards EN 60204-1 and EN ISO 12100 at the least, and in accordance with 2006/95/EC.

Concerning electrical equipment designed for use within certain voltage limits, the Gold Cello meets the provisions outlined in 2006/95/EC. The party responsible for ensuring that the equipment meets the limits required by EMC regulations is the manufacturer of the end product.

## 2.4. Warranty Information

The products covered in this manual are warranted to be free of defects in material and workmanship and conform to the specifications stated either within this document or in the product catalog description. All Elmo drives are warranted for a period of 12 months from the time of installation, or 12 months from time of shipment, whichever comes first. No other warranties, expressed or implied — and including a warranty of merchantability and fitness for a particular purpose — extend beyond this warranty.



## ***Chapter 3: Product Description***

The Gold Cello is an advanced high power density servo drive which delivers up to **3.3 kW of continuous power** or **6.6 kW of peak power** in a 469.35 cc (28.3 in<sup>3</sup>) package (150 x 105 x 29.8 mm or 5.9" x 4.1" x 1.17").

This advanced, high power density servo drive provides top performance, advanced networking and built-in safety, as well as a fully featured motion controller and local intelligence. The Gold Cello is powered by a single 14 V – 195 V isolated DC power source (not included) and a “smart” control-supply algorithm enables the drive to operate with only one power supply with no need for an auxiliary power supply for the logic.

The Gold Cello can operate as a stand-alone device or as part of a multi-axis system in a distributed configuration on a real-time network.

The Gold Cello drive is easily set up and tuned using Elmo Application Studio (EASII) software tools. As part of the Gold product line, it is fully programmable with the Elmo motion control language. For more about software tools, refer to the Elmo Application Studio Software Manual.

The Gold Cello is available in a variety of options. There are multiple power rating options, two different communications options, a variety of feedback selections and I/O configuration possibilities.

### **3.1.1. Accessories**

Gold Cello Cable Kit, catalog number: CBL-GCELKIT (can be ordered separately)

For further details, see the MAN-G-CEL-CBLKIT documentation for this cable kit.





## Chapter 4: Technical Information

### 4.1. Physical Specifications

Feature	Units	All Types
Weight	g (oz)	484 g (17.07 oz)
Dimensions	mm (in)	150 x 105 x 29.8 mm (5.9" x 4.1" x 1.17")
Mounting method		Panel mounted (on back or on side)

### 4.2. Technical Data

Feature	Units	All Types					
		20/100	35/100	50/100	10/200	17/200	20/200
Minimum supply voltage	VDC	14			23		
Nominal supply voltage	VDC	85			170		
Maximum supply voltage	VDC	96			195		
Maximum continuous power output	W	1600	2800	4000	1650	2800	3300
Efficiency at rated power (at nominal conditions)	%	> 98					
Maximum output voltage	VDC	14 V to 96 V			23 V to 195 V		
Continuous current limit (I <sub>c</sub> ) amplitude of sinusoidal current, or DC trapezoidal commutation	A	20	35	50	10	17	20
Sinusoidal continuous RMS current limit (I <sub>c</sub> )	A	14.2	24.7	35.4	7.07	12	17.7
Peak current limit	A	2 x I <sub>c</sub>			2 x I <sub>c</sub>		

**Table 1: Power Ratings**

**Note on current ratings:** The current ratings of the Gold Cello are given in units of DC amperes (ratings that are used for trapezoidal commutation or DC motors). The RMS (sinusoidal commutation) value is the DC value divided by 1.41.



### 4.2.1. Auxiliary Supply

Feature	Details
Auxiliary power supply	Isolated DC source only
Auxiliary supply input voltage	14 to 96 V (100 V models) 23 to 195 VDC (200 V models)
Auxiliary supply input power	≤ 5 VA without external loading ≤ 8 VA with full external loading

### 4.2.2. Product Features

Main Feature	Details	Presence and No.
<b>STO</b>	TTL	√
	PLC Source	√
	PLC Sink	<b>is not fully certified , and not recommended for new designs</b>
<b>Digital Input Option</b>	TTL	6
	PLC Source	6
	PLC Sink	6
<b>Digital Output Option</b>	TTL	4
	PLC Source	4
	PLC Sink	4
<b>Analog Input</b>	Differential ±10V	1
<b>Feedback</b>	Standard Port A, B, & C	√
<b>Communication Option</b>	USB	√
	EtherCAT	√
	CAN	√



### 4.3. Environmental Conditions

You can guarantee the safe operation of the Gold Cello by ensuring that it is installed in an appropriate environment.

#### 4.3.1. Gold Line

Feature	Details
<b>Operating ambient temperature according to IEC60068-2-2</b>	0 °C to 40 °C (32 °F to 104 °F)
<b>Storage temperature</b>	-20 °C to +85 °C ( -4 °F to +185 °F)
<b>Maximum non-condensing humidity according to IEC60068-2-78</b>	95%
<b>Maximum Operating Altitude</b>	2,000 m (6562 feet) It should be noted that servo drives capable of higher operating altitudes are available on request.
<b>Mechanical Shock according to IEC60068-2-27</b>	15g / 11ms Half Sine
<b>Vibration according to IEC60068-2-6</b>	5 Hz ≤ f ≤ 10 Hz: ±10mm 10 Hz ≤ f ≤ 57 Hz: 4G 57 Hz ≤ f ≤ 500 Hz:5G



## 4.4. Gold Line Standards

The following table describes the Main Standards of the Gold Cello servo drive. For further details refer to the MAN-G-Panel Mounted Drives Hardware manual.

Main Standards	Item
The related standards below apply to the performance of the servo drives as stated in the environmental conditions in section 4.3.1 Gold Line above.	
<b>STO IEC 61800-5-2:2007 SIL 3</b>	Adjustable speed electrical power drive systems – Safety requirements – Functional
<b>EN ISO 13849-1:2008 PL e, Cat 3</b>	Safety of machinery — Safety-related parts of control systems.
<b>Approved IEC/EN 61800-5-1</b>	Adjustable speed electrical power drive systems Safety requirements – Electrical, thermal and energy
<b>Recognized UL61800-5-1</b>	Adjustable speed electrical power drive systems Safety requirements – Electrical, thermal and energy
<b>Recognized UL 508C</b>	Power Conversion Equipment
<b>In compliance with UL 840</b>	Insulation Coordination Including Clearances and Creepage Distances for Electrical Equipment
<b>Conformity with CE 2006/95/EC</b>	Low-voltage directive 2006/95/EC
<b>Recognized CSA C22.2 NO. 14-13</b>	Industrial Control Equipment



## Chapter 5: Installation

The Gold Cello must be installed in a suitable environment and properly connected to its voltage supplies and the motor.

### 5.1. Unpacking the Drive Components

Before you begin working with the Gold Cello, verify that you have all of its components, as follows:

- The Gold Cello servo drive
- The Elmo Application Studio (EAS) software and software manual

The Gold Cello is shipped in a cardboard box with Styrofoam protection.

#### To unpack the Gold Cello:

1. Carefully remove the servo drive from the box and the Styrofoam.
2. Check the drive to ensure that there is no visible damage to the instrument. If any damage has occurred, report it immediately to the carrier that delivered your drive.
3. To ensure that the Gold Cello you have unpacked is the appropriate type for your requirements, locate the part number sticker on the side of the Gold Cello. It looks like this:



GCEL005A

4. Verify that the Gold Cello type is the one that you ordered, and ensure that the voltage meets your specific requirements.

The part number at the top provides the type designation. Refer to the appropriate part number in the section Catalog Number at the beginning of the installation guide.

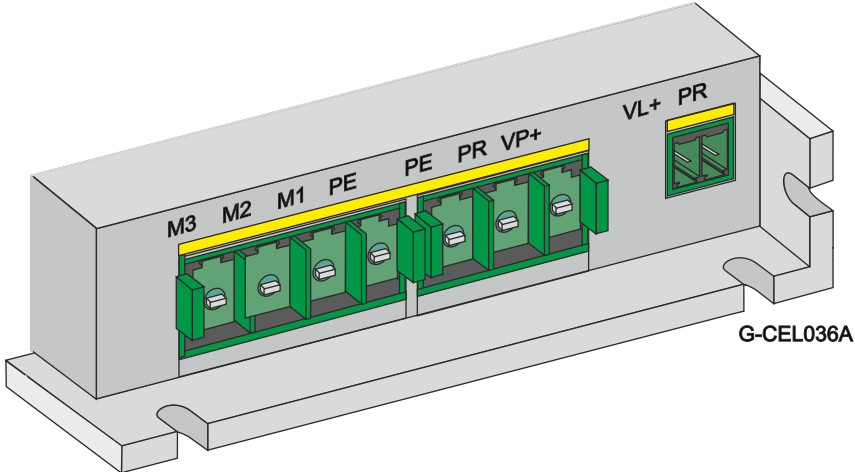
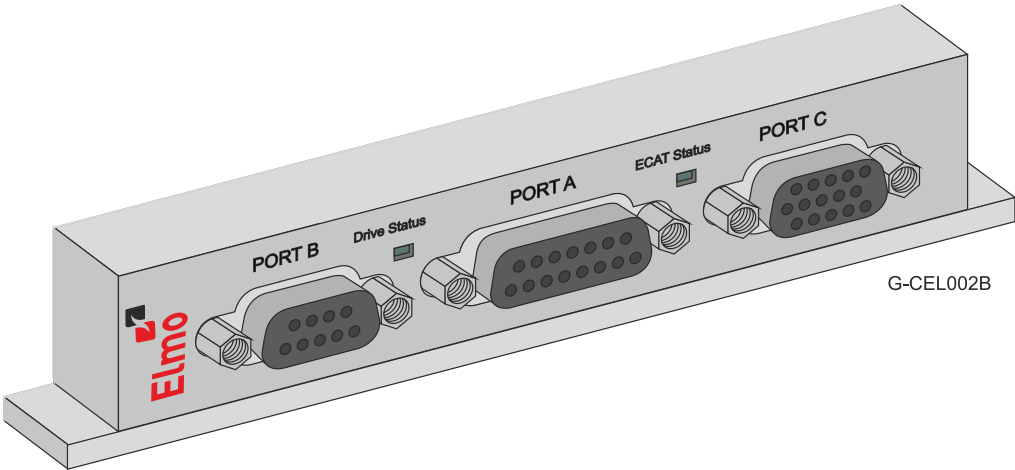


## 5.2. Connectors and Indicators

The Gold Cello has 10 connectors.

### 5.2.1. EtherCAT Connector Types

The EtherCAT Gold Cello has the following connectors:

No. Pins	Type	Function
<b>Bottom Connectors</b>		
		
4	Phoenix 7.62 mm Pitch	Motor phases
3	Phoenix 7.62 mm Pitch	Main Power
2	Phoenix 3.81 mm Pitch	Auxiliary supply input
<b>Front Connectors</b>		
		
<b>Front Connectors - EtherCAT</b>		
15	Socket D-Type	Port A
9	Socket D-Type	Port B
15	Socket High Density D-Type	Port C and Safety



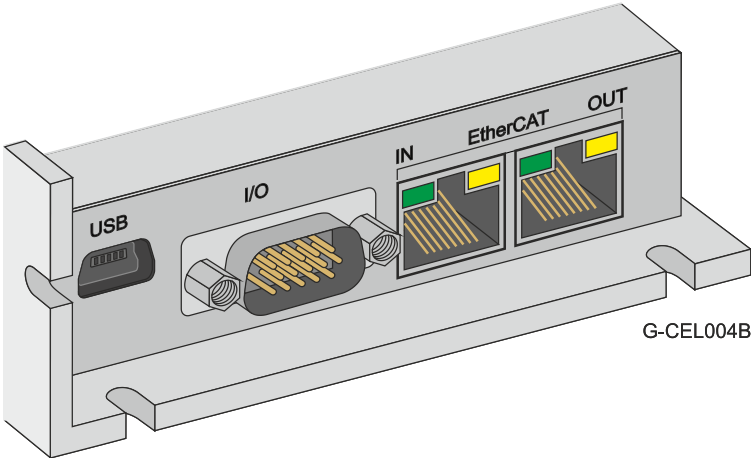
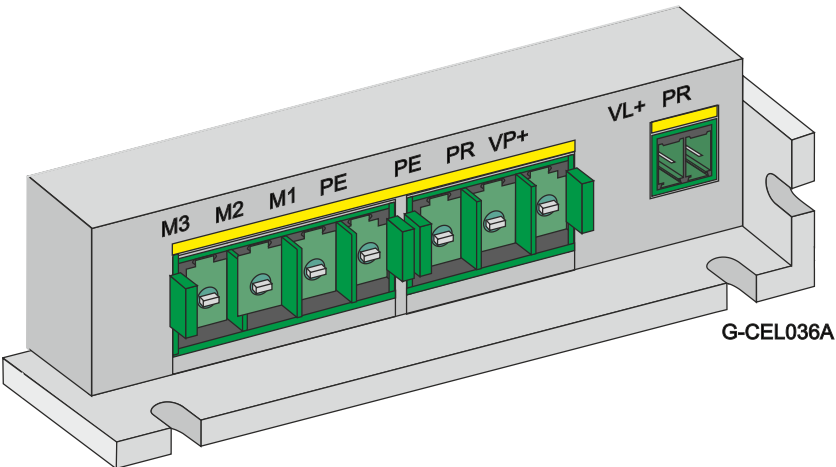
No. Pins	Type	Function
<b>Top Connectors</b>		
		
<b>Top Connectors - EtherCAT</b>		
15	Pin High Density D-Type	I/O
5	USB Device Mini-B	USB
<b>EtherCAT Version</b>		
8	RJ-45	Ethernet/EtherCAT_IN communication
8	RJ-45	EtherCAT OUT communication

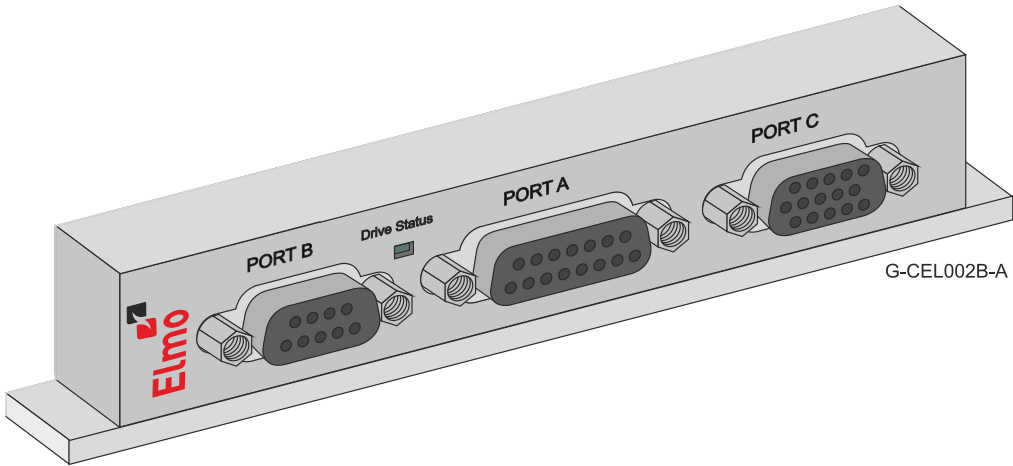
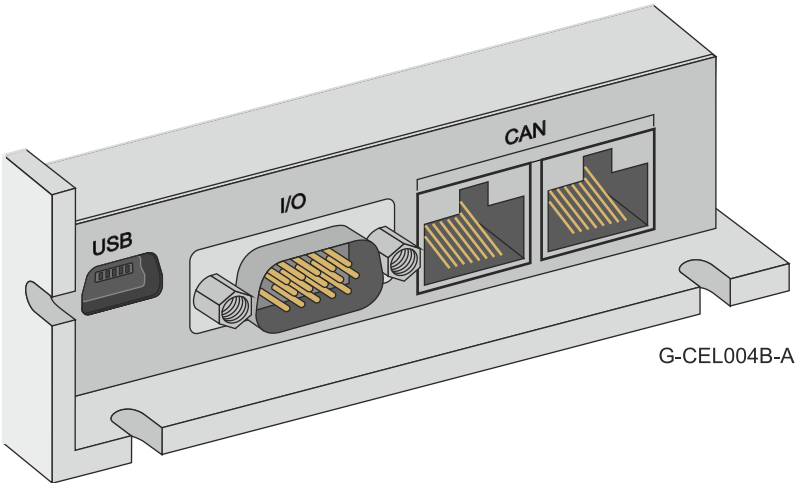
Table 2: EtherCAT Connector Types

### 5.2.2. CAN Connector Types

The CAN Gold Cello has the following connectors:

No. Pins	Type	Function
<b>Bottom Connectors</b>		
		
4	Phoenix 7.62 mm Pitch	Motor phases
3	Phoenix 7.62 mm Pitch	Main Power



No. Pins	Type	Function
2	Phoenix 3.81 mm Pitch	Auxiliary supply input
<b>Front Connectors</b>		
 <p style="text-align: center;"><b>Front Connectors - CAN</b></p>		
15	Socket D-Type	Port A
9	Socket D-Type	Port B
15	Socket High Density D-Type	Port C and Safety
<b>Top Connectors</b>		
 <p style="text-align: center;"><b>Top Connectors - CAN</b></p>		
15	Pin High Density D-Type	I/O
5	USB Device Mini-B	USB
<b>CAN Version</b>		
8	RJ-45	CAN communication
8	RJ-45	CAN communication

**Table 3: CAN Connector Types**





### 5.3. Mounting the Gold Cello

The Gold Cello has been designed for two standard mounting options:

- Wall Mount along the back (can also be mounted horizontally on a metal surface)
- Book Shelf along the side

M4 round head screws, one through each opening in the heat sink, are used to mount the Gold Cello (see the diagram below).

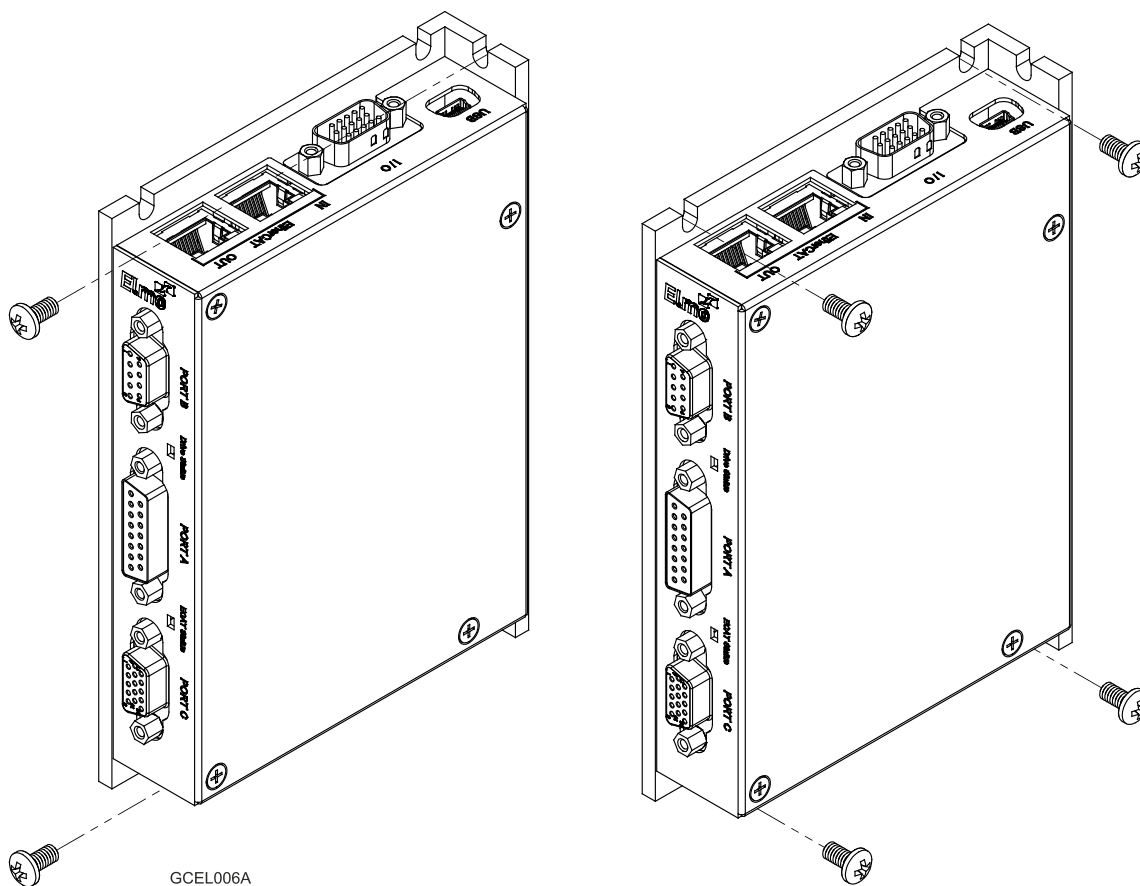
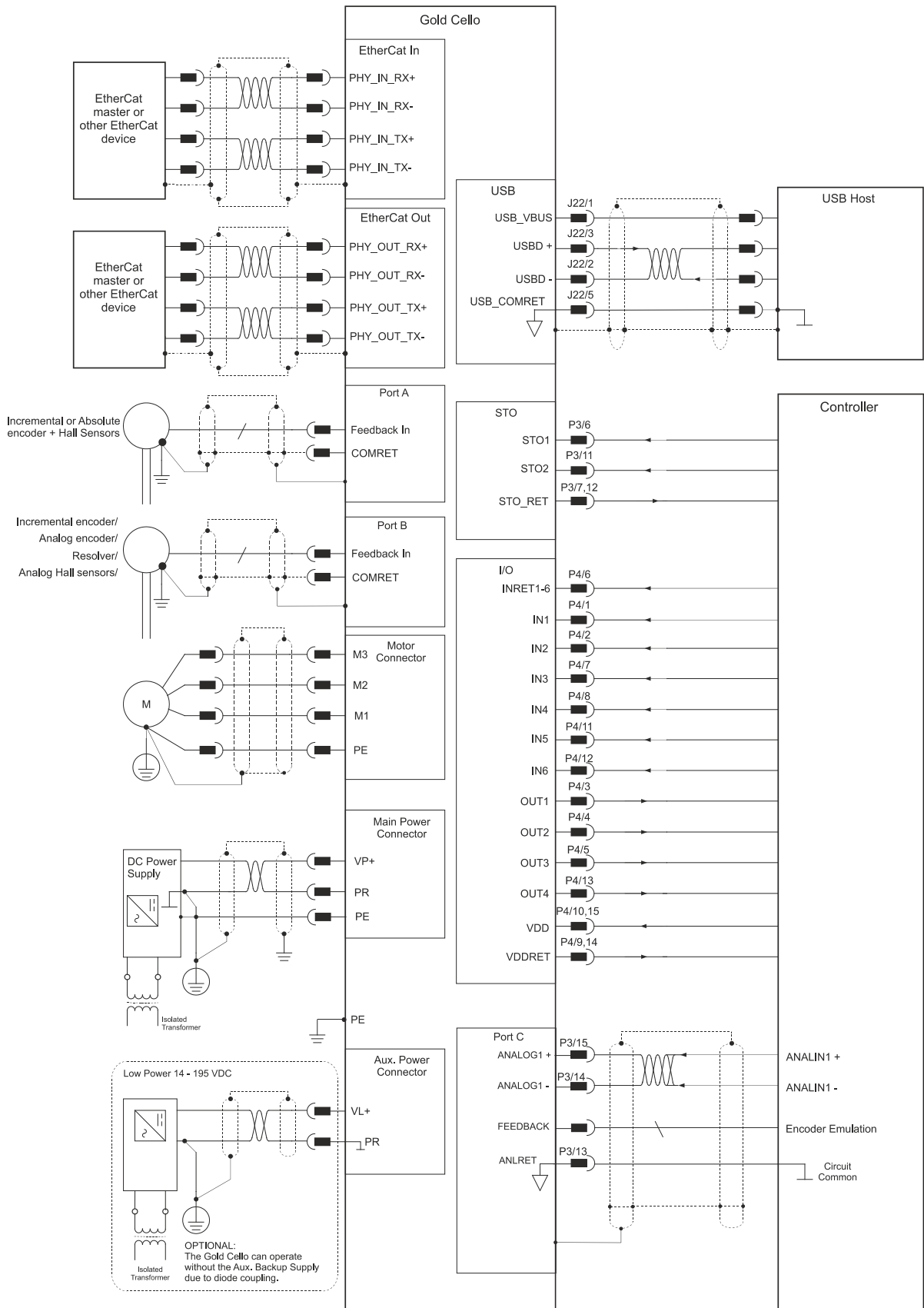


Figure 1: Mounting the Gold Cello



## 5.4. Gold Cello Connection Diagrams



GCEL026B

Figure 2: Gold Cello Connection Diagram – EtherCAT

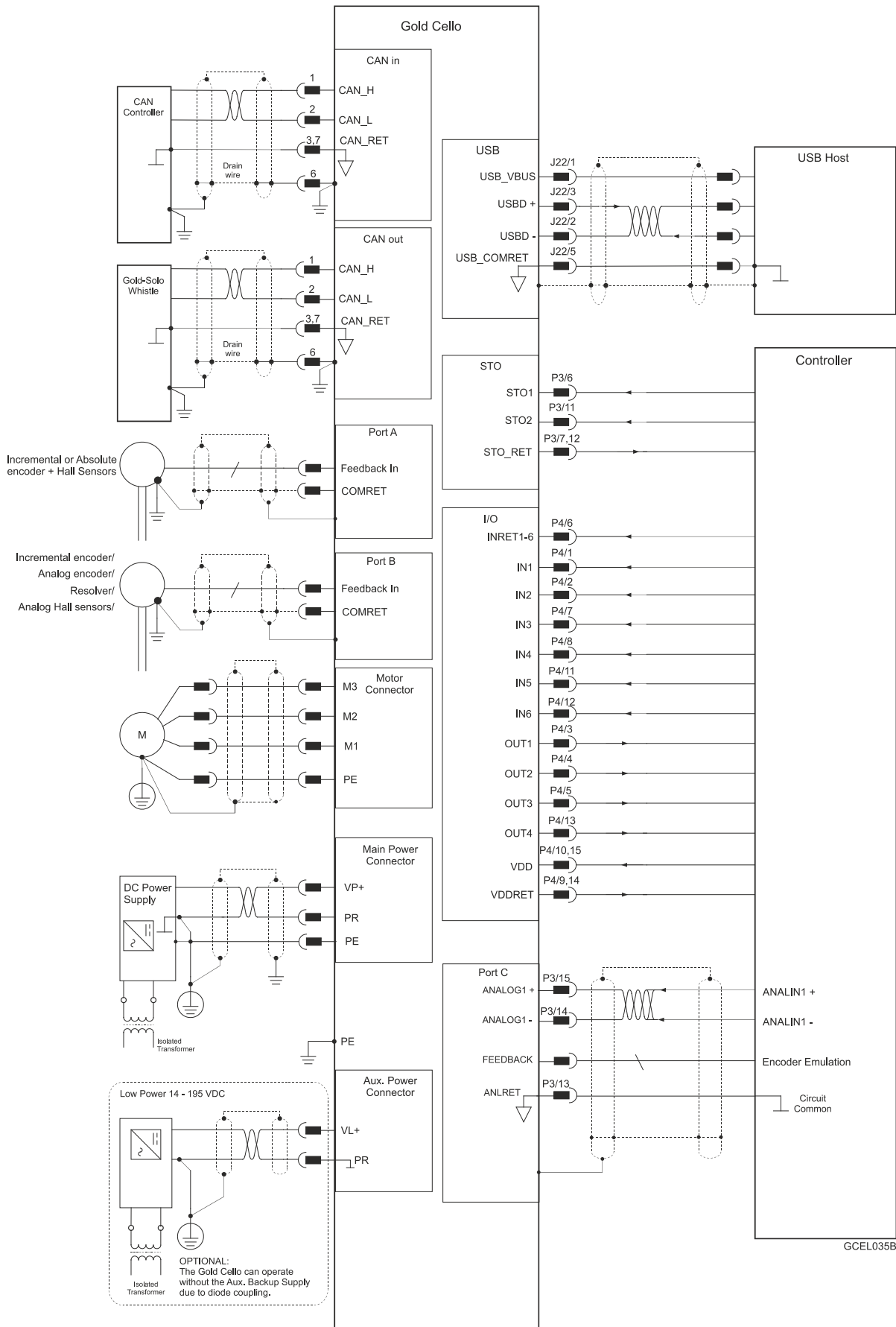



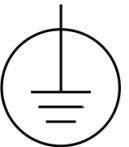
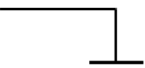
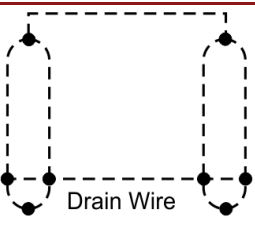
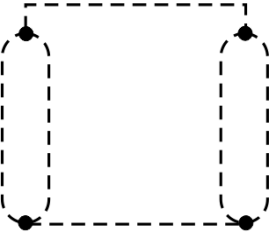
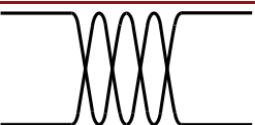
Figure 3: Gold Cello Connection Diagram – CAN



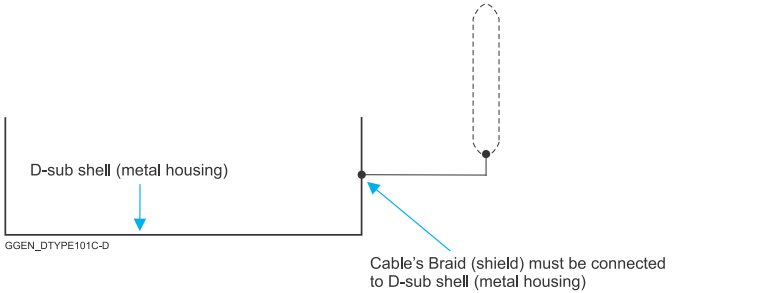
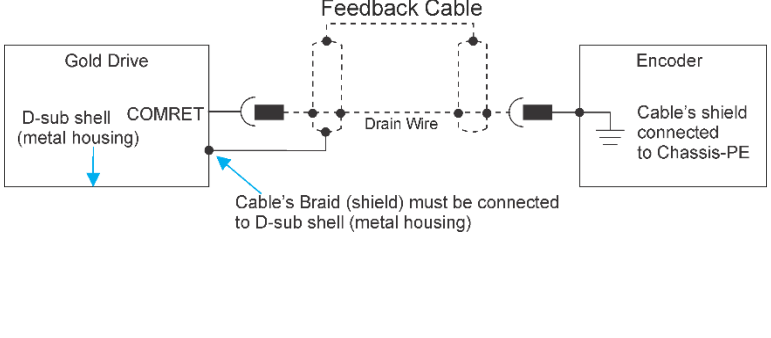
## Chapter 6: Wiring

Once the product is mounted, you are ready to wire the device. Proper wiring, grounding and shielding are essential for ensuring safe, immune and optimal servo performance of the drive.

The following table legend describes the wiring symbols detailed in all installation guides.

Wiring Symbol	Description
 GGEN_101D-A	Earth connection (PE)
 GGEN_101D-B	Protective Earth Connection
 GGEN_101D-C	Common at the Controller
 GGEN_101D-D	Shielded cable with drain wire. The drain wire is a non-insulated wire that is in direct contact with the braid (shielding). Shielded cable with drain wire significantly simplifies the wiring and earthing.
 GGEN_101D-E	Shielded cable braid only, without drain wire.
 GGEN_101D-F	Twisted-pair wires



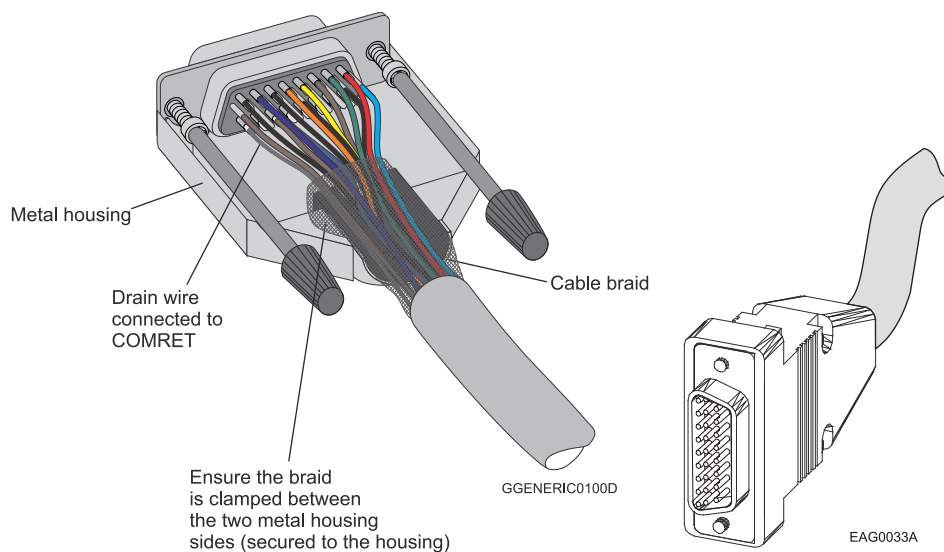
Wiring Symbol	Description
 <p>D-sub shell (metal housing)</p> <p>GGEN_DTYPE101C-D</p> <p>Cable's Braid (shield) must be connected to D-sub shell (metal housing)</p>	<p>D-type Connector: The cable's braid (Shield) must be connected to the D-sub shell (metal housing)</p>
 <p>Gold Drive</p> <p>D-sub shell (metal housing)</p> <p>COMRET</p> <p>Feedback Cable</p> <p>Drain Wire</p> <p>Encoder</p> <p>Cable's shield connected to Chassis-PE</p> <p>Cable's Braid (shield) must be connected to D-sub shell (metal housing)</p>	<p>Encoder Earthing.</p> <p>The cable's shield is connected to the chassis (PE) in the connector.</p> <p>Earthing the Encoder and connecting the Earth (PE) to the drive COMRET is mandatory to insure reliable operation, high noise immunity and rejection of voltage common mode interferences.</p>



## 6.1. Basic Recommendations

### 6.1.1. General

1. Use shielded cables. For best results, the cable should have an aluminum foil shield covered by copper braid, and should contain a drain wire.  
Use 24, 26 or 28 AWG twisted-pair shielded with drain wire cables.
2. Keep the cable as short as possible.  
Do not mount the power cables of the motor and power bus in the proximity of the control and feedback cables.
3. Ensure that in normal operating conditions, the “earth connection” wires and shield of the control cables *carry no current*. The only time these conductors carry current is under abnormal conditions, when electrical equipment has become a potential shock or fire hazard while conducting external EMI interferences directly to ground, in order to prevent them from affecting the drive. Failing to meet this requirement might result in drive/controller/host failure.
4. After completing the wiring, carefully inspect all wires to ensure tightness, good solder of joints and general safety.



**Figure 4: D-Type Cable Assemblies**

5. Use only a D-Sub connector with a **metal housing** (Figure 4).
6. Make sure the braid shield is in tight contact with the metal housing of the D-type connector (Figure 4).



### 6.1.2. Feedback Cable Port A and Port B Connector

1. On the motor side connections, ground the shield to the motor chassis.
2. At least One COMRET (Common Return) must be connected to the PE.

Implement the following steps to connect the COMRET to the PE:

- a. At the drive, connect the feedback drain wire to one of the COMRET terminals in the D-Type feedback connector (Figure 5).
- b. At the motor, connect the feedback cable drain wire to the GND motor chassis terminal of the feedback connector.

The drawings below display two earth connections.

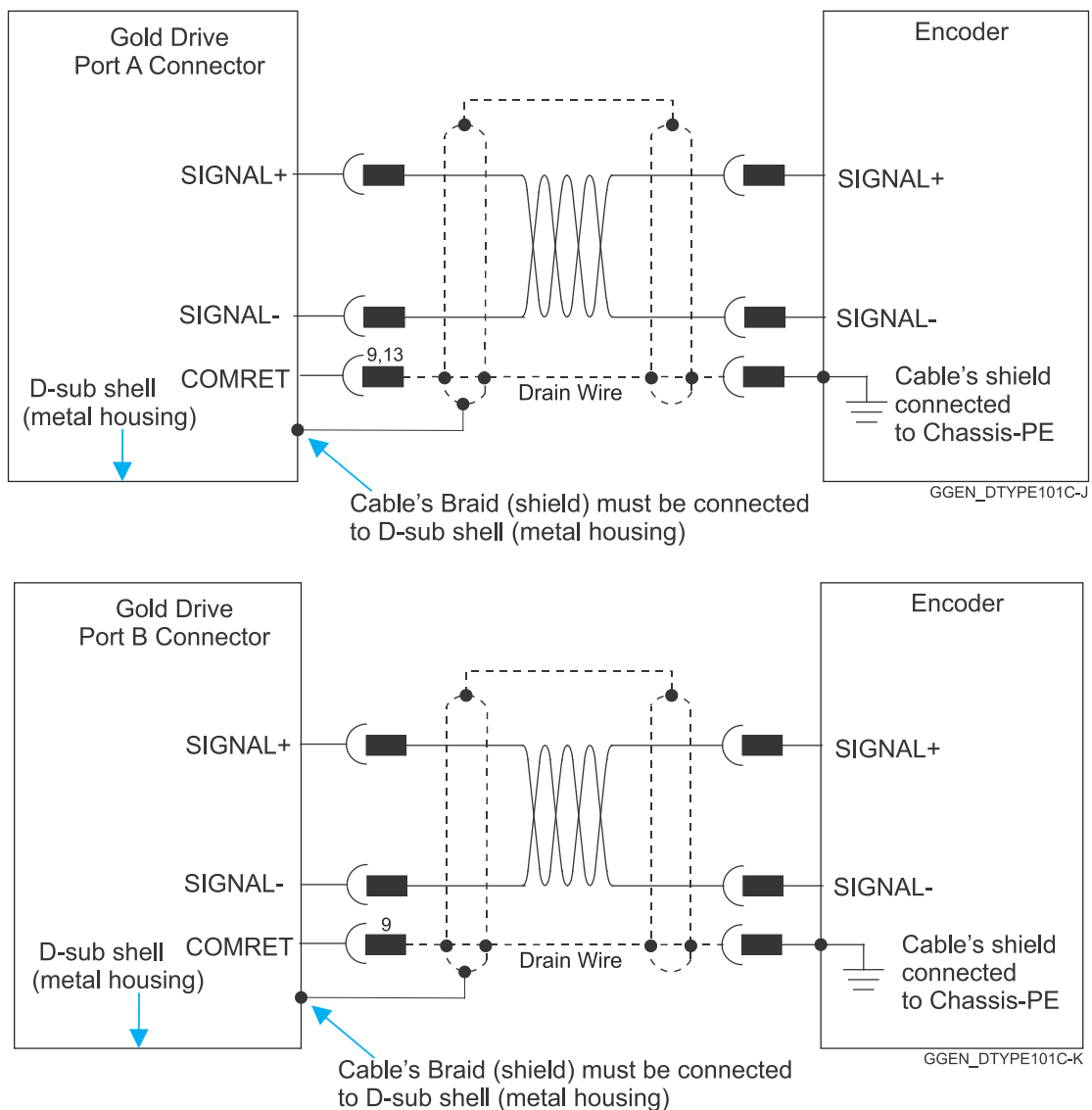


Figure 5: Feedback Port A and B Cable Assemblies



### 6.1.3. Feedback Cable Port C Connector

1. At the controller side connections, follow the controller manufacturer's recommendations concerning the shield.
2. The connection of the Drain wire to the Port C is not mandatory.

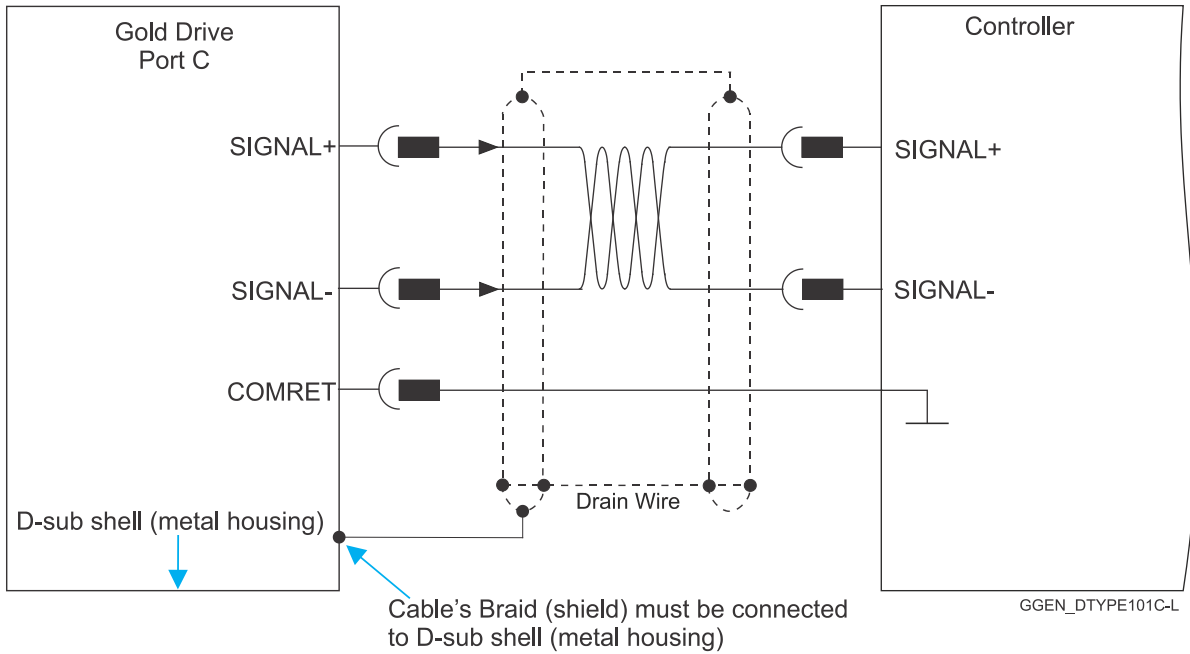


Figure 6: Feedback Port C Cable Assemblies

### 6.1.4. IO Cable Connector

It is recommended to use shielded cable, but is not mandatory.

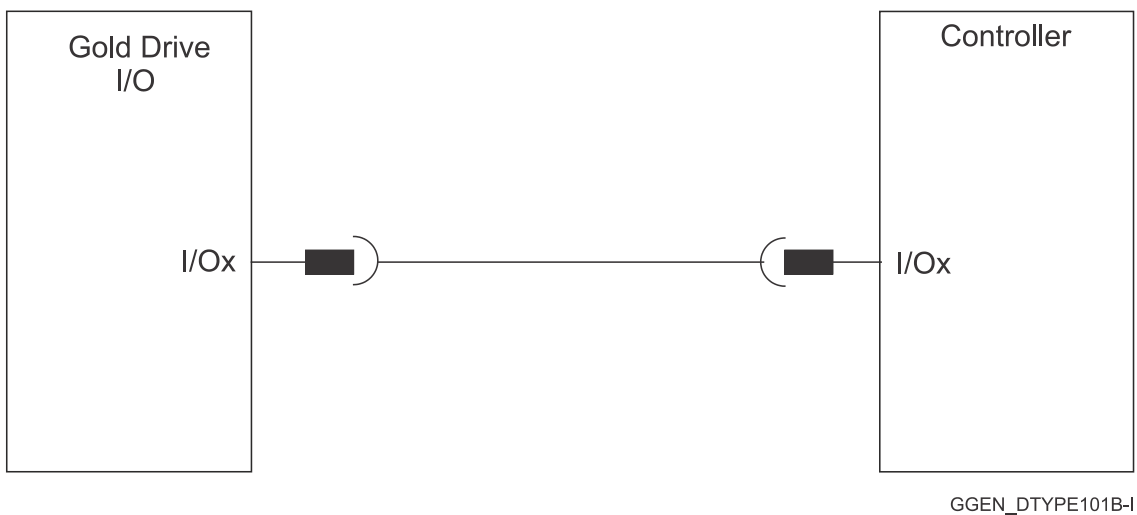


Figure 7: Feedback IO Cable Assemblies





### 6.1.5. STO (Port C) Cable Connector

It is recommended to use shielded cable, but is not mandatory.

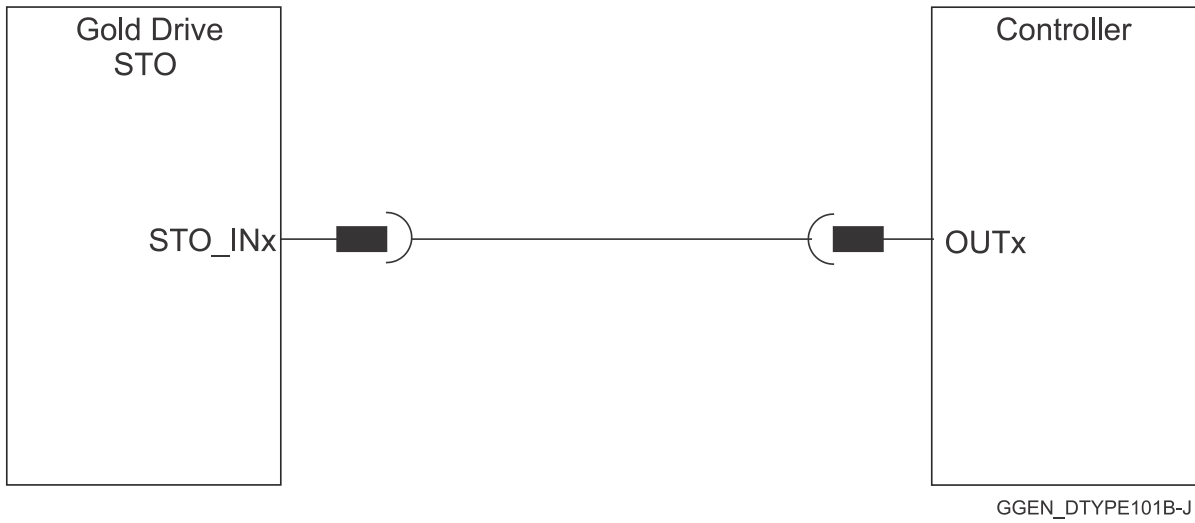


Figure 8: STO Cable Assemblies



## 6.2. Motor Power Connector Pinouts (J9)

See Chapter 8 in the in the MAN-G-Panel Mounted Drives Hardware manual for full details.

Signal (J9)	Function	Cable	
		Brushless Motor	Brushed DC Motor
M3	Motor phase	Motor	Motor
M2	Motor phase	Motor	Motor
M1	Motor phase	Motor	N/C
PE	Protective Earth Motor Chassis	Motor	Motor

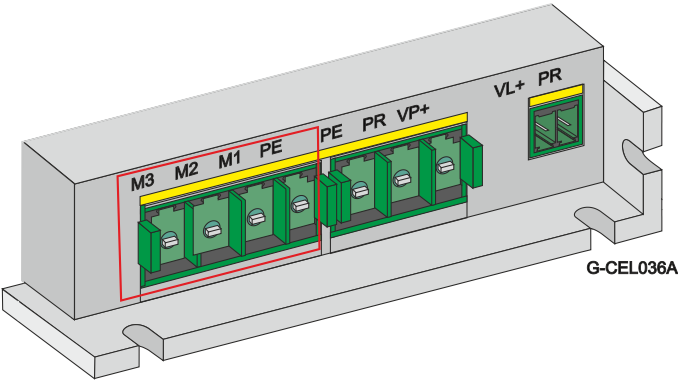
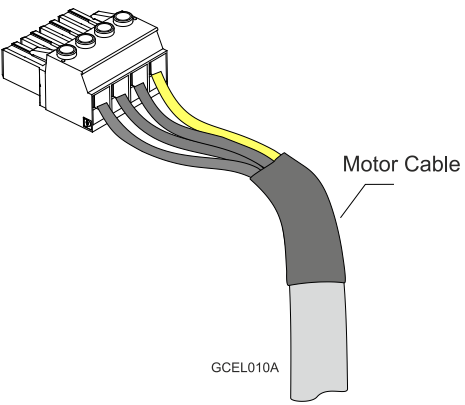
Pin Positions	
 <p><b>4-Pin Phoenix 7.62 mm Pitch</b></p>	 <p><b>4-Pin Phoenix Plug-in Connector</b></p>

Table 4: Connectors for Motor

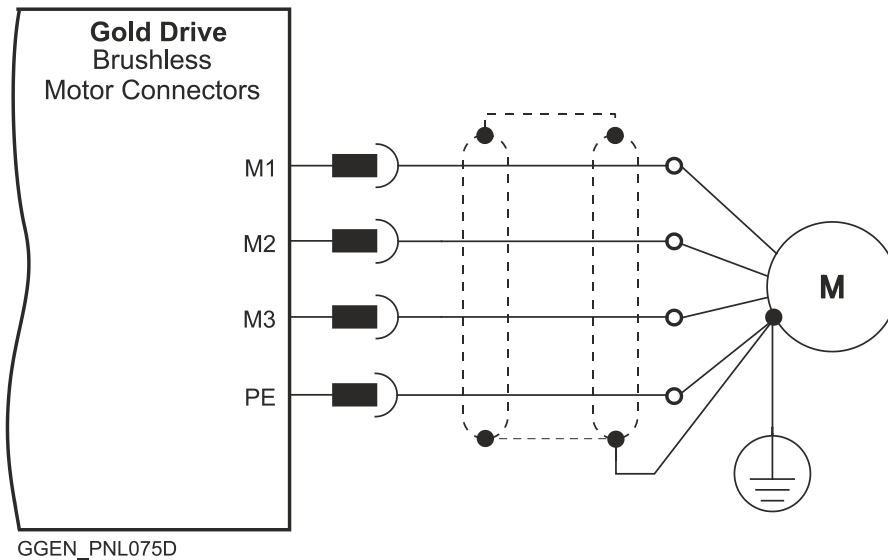


Figure 9: Brushless Motor Power Connection Diagram

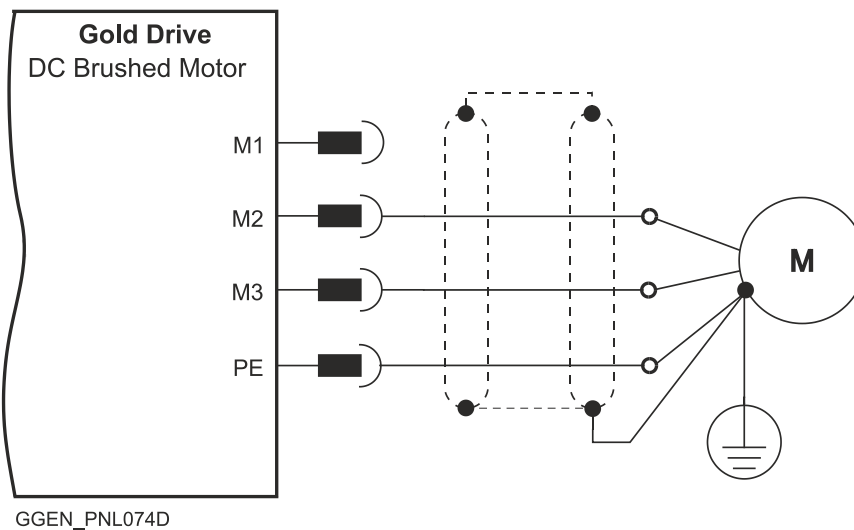


Figure 10: DC Brushed Motor Power Connection Diagram

To power the drive, connect the M1, M2, M3, and PE pins on the Gold Cello. The phase connection is arbitrary as Elmo Application Studio (EASII) will establish the proper commutation automatically during setup. When tuning a number of drives, you can copy the setup file to the other drives and thus avoid tuning each drive separately. In this case the motor-phase order must be the same as on the first drive.

- For best immunity, it is highly recommended to use a 4-wire shielded (not twisted) cable for the motor connection. The gauge is determined by the actual current consumption of the motor.
- Connect the cable shield to the closest ground connection at the motor end.
- For better EMI performance, the shield should be connected to Protective Earth (PE terminal). Connect the Braid wire to the PE terminal on the motor connector.
- Ensure that the motor chassis is properly grounded.

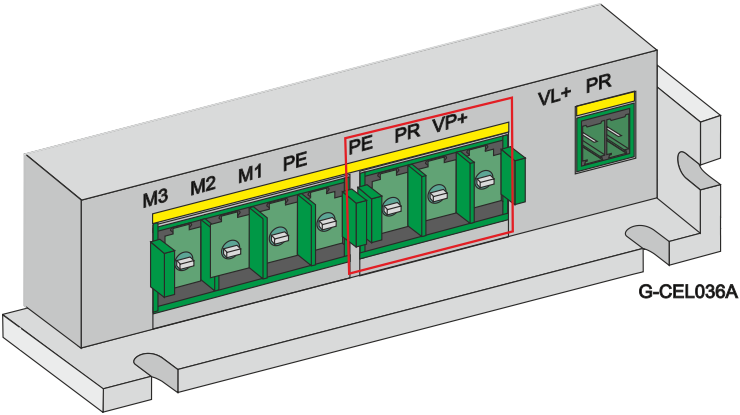


### 6.3. Main Power (J11)

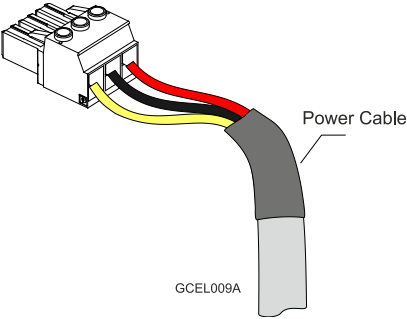
The Gold Cello receives power from main and auxiliary supplies and delivers power to the motor.

**Note:** There are multiple voltage ratings of the Gold Cello (14 V to 195 V), so you must use the correct power supply according to the maximum operating voltage of the Gold Cello. Refer to section 4.2 Technical Data.

Signal (J11)	Function	Cable
VP+	Positive Power input	DC Power
PR	Power return	DC Power
PE	Protective earth	DC Power



**3-Pin Phoenix 7.62 mm Pitch**



**3-Pin Phoenix Plug-in Connector**

Table 5: Connectors for Main Power

Power to the Gold Cello is provided by a 14 to 195 VDC source. A smart control-supply algorithm enables the drive to operate with the power supply only, with no need for an auxiliary supply.

Connect the DC power cable to the VP+ and PR terminals on the Main Power Connector.

**To connect the DC power supply:**

- The source of the 14 to 195 VDC power supply must be isolated.
- For best immunity, it is highly recommended to use twisted and shielded cables for the DC power supply. A 3-wire shielded cable should be used. The gauge is determined by the actual current consumption of the motor.
- Connect the cable shield to the closest ground connection near the power supply.
- Connect the PE to the closest ground connection near the power supply.
- Connect the PR to the closest ground connection near the power supply.
- Before applying power, first verify the polarity of the connection.

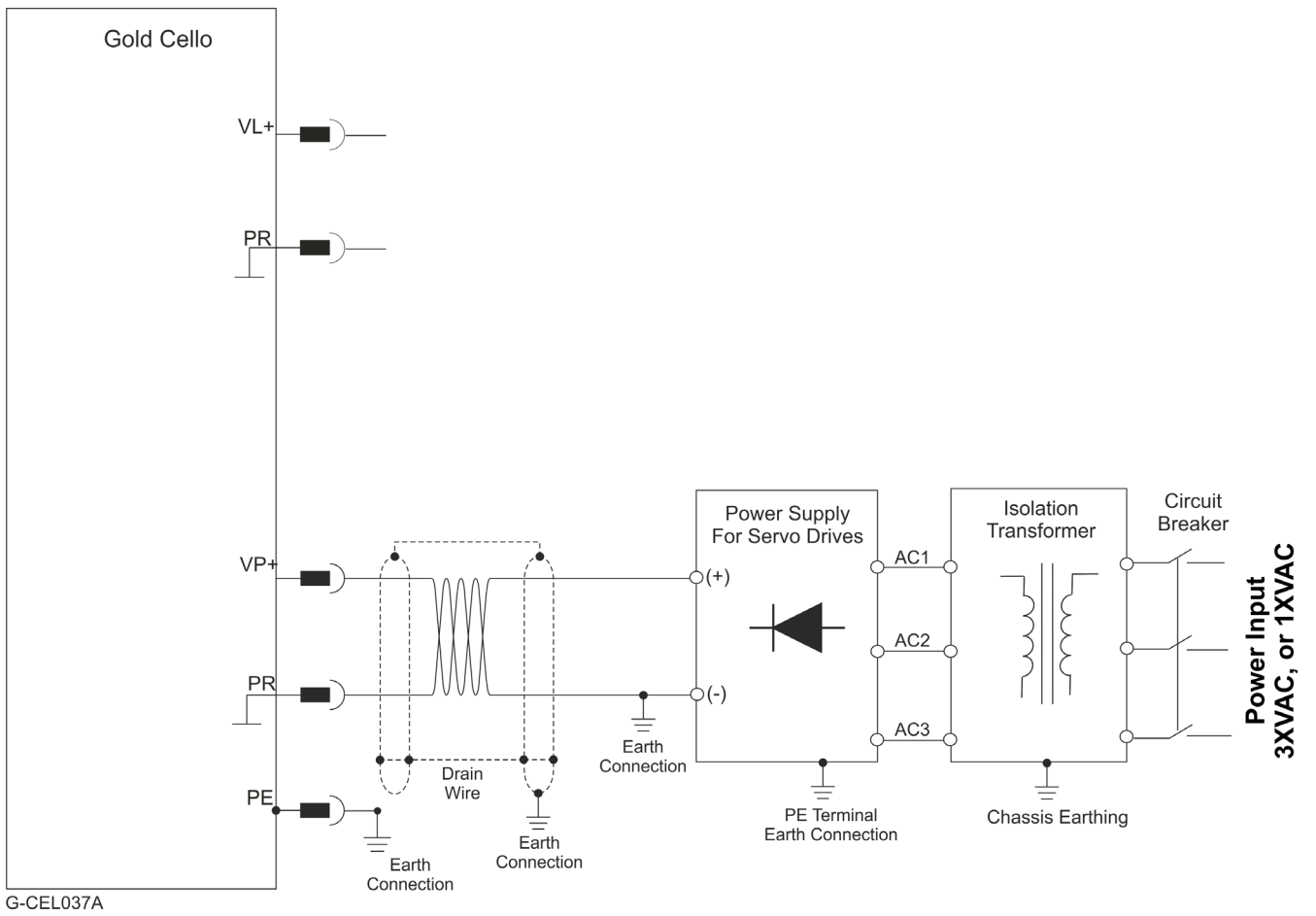


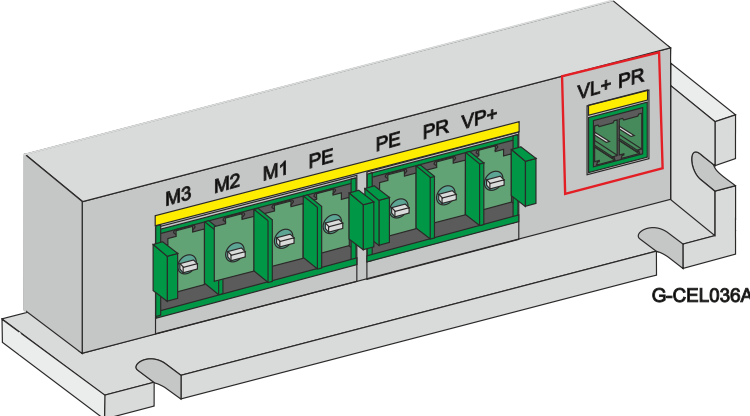
Figure 11: Main Power Supply Connection Diagram (no Auxiliary Supply)



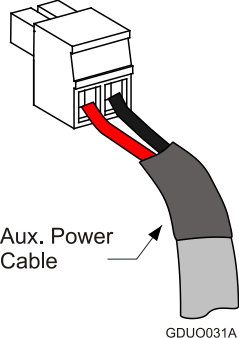
## 6.4. Auxiliary Power (J10)(optional)

Signal (J10)	Function	Cable
VL+	Auxiliary Supply Input	DC Power
PR	Auxiliary Supply Return	DC Power



**2-Pin Phoenix 3.81 mm Pitch**



**2-Pin Phoenix Plug-in Connector**

Table 6: Aux. Power Connector – Pin Assignments



**Caution:** Power from the Gold Cello to the motor must come from the Main Supply and **not** from the Auxiliary Supply.

**Note:** The source of the Auxiliary Supply must be isolated.

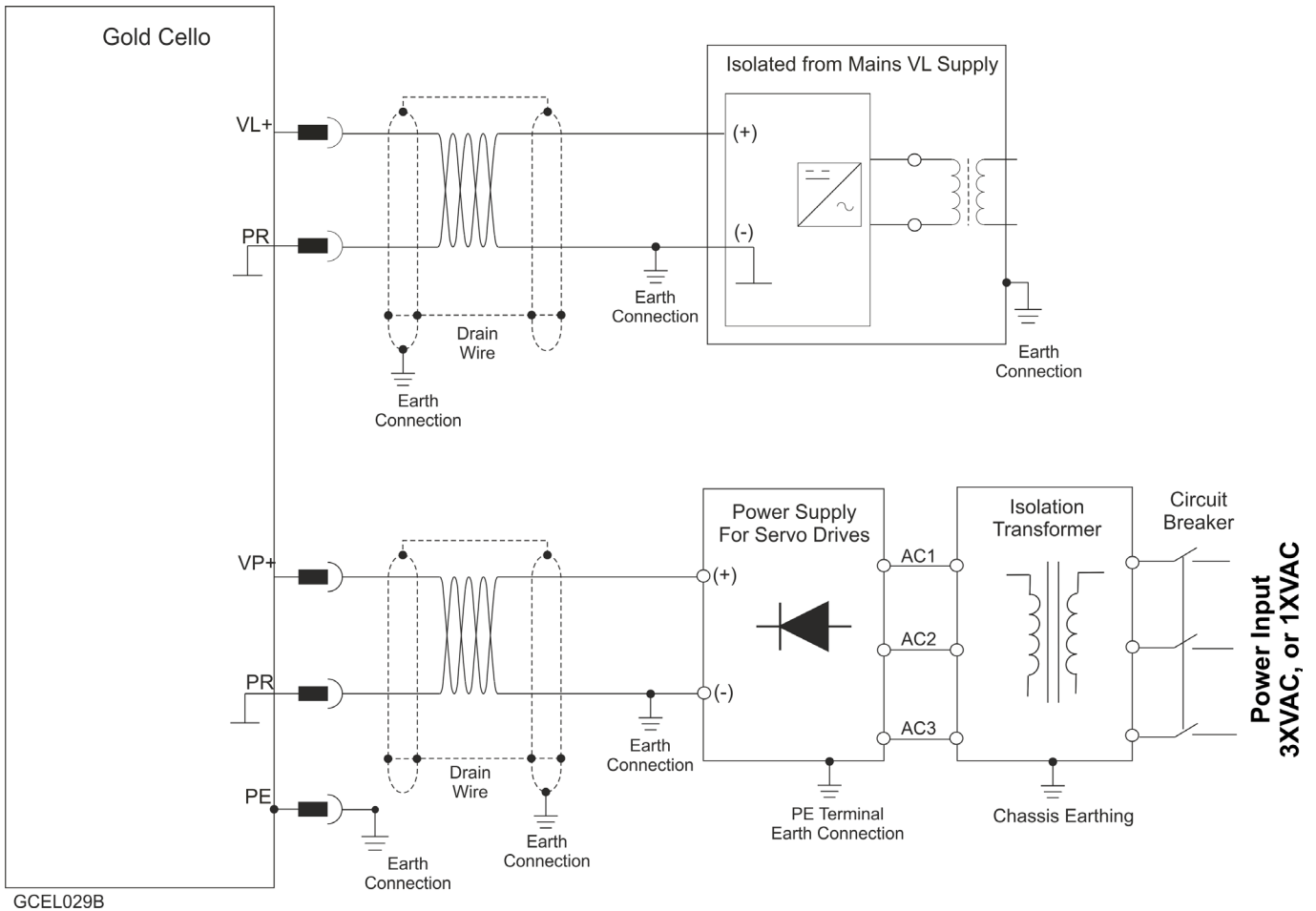
Connect the VL and PR pins on the Gold Cello in the manner described below.

Power to the Auxiliary Supply can be provided by a separate Auxiliary Supply.



**To connect the auxiliary supply:**

- The source of the auxiliary supply must be isolated.
- For safety reasons, connect the return (common) of the auxiliary supply source to the closest ground near the auxiliary supply source.
- Connect the cable shield to the closest ground near the auxiliary supply source.
- Before applying power, first verify the polarity of the connection.



**Figure 12: Separate Auxiliary Supply Connection Diagram**



## 6.5. Drive Status Indicator

The Gold Cello is equipped with several light-emitting diode (LED) indicators.

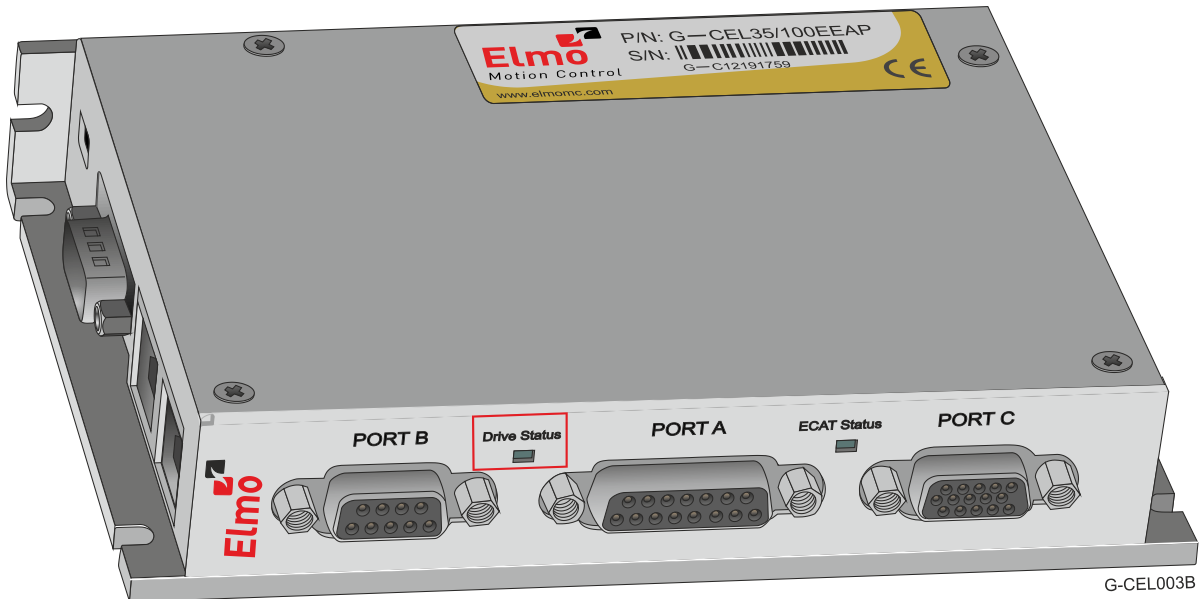


Figure 13: Drive Status LED

The red/green dual LED is used for immediate indication of the following states:

- **Initiation state:** In this state the LED indicates whether the drive is in the boot state (blinking red) or in the operational state (steady red).
- **Working state:** In this state the LED indicates whether the drive is in an amplifier failure state (red) or is ready to enable the motor (green).



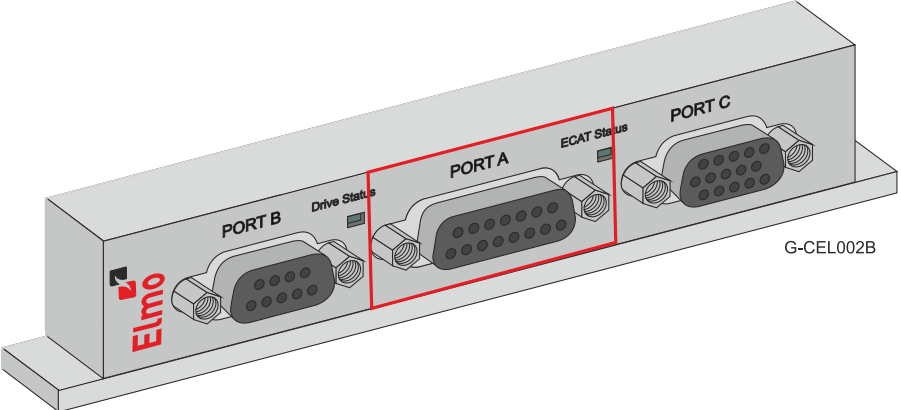
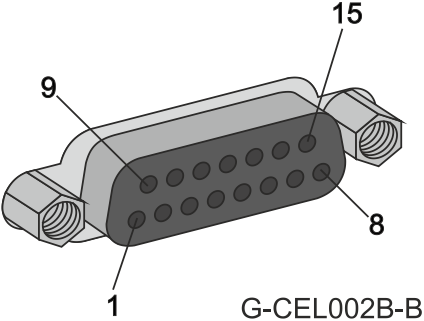


## 6.6. Port A (P1)

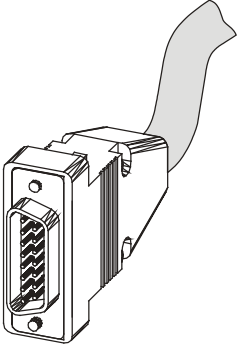
See Section 10.3 in the in the MAN-G-Panel Mounted Drives Hardware manual for full details.

		Incremental Encoder		Absolute Serial Encoder	
Pin (P1)	Signal	Function	Signal	Function	
12,4	+5V	Encoder +5V supply	+5V	Encoder +5V supply	
3,9,11,13	COMRET	Common return	COMRET	Common return	
6	PortA_ENC_A+	Channel A+	ABS_CLK+	Abs encoder clock +	
5	PortA_ENC_A-	Channel A-	ABS_CLK-	Abs encoder clock -	
15	PortA_ENC_B+	Channel B+	ABS_DATA+	Abs encoder data +	
14	PortA_ENC_B-	Channel B-	ABS_DATA-	Abs encoder data -	
8	PortA_ENC_INDEX+	Index+	Reserved	Reserved	
7	PortA_ENC_INDEX-	Index-	Reserved	Reserved	
2	HA	Hall sensor A	HA	Hall sensor A	
10	HB	Hall sensor B	HB	Hall sensor B	
1	HC	Hall sensor C	HC	Hall sensor C	

**15-Pin D-Type Female Connector**



**15-Pin D-Type Male Connector**

Table 7: Port A Pin Assignments



### 6.6.1. Incremental Encoder

The following figure describes the connections at Port A for the Incremental encoder.

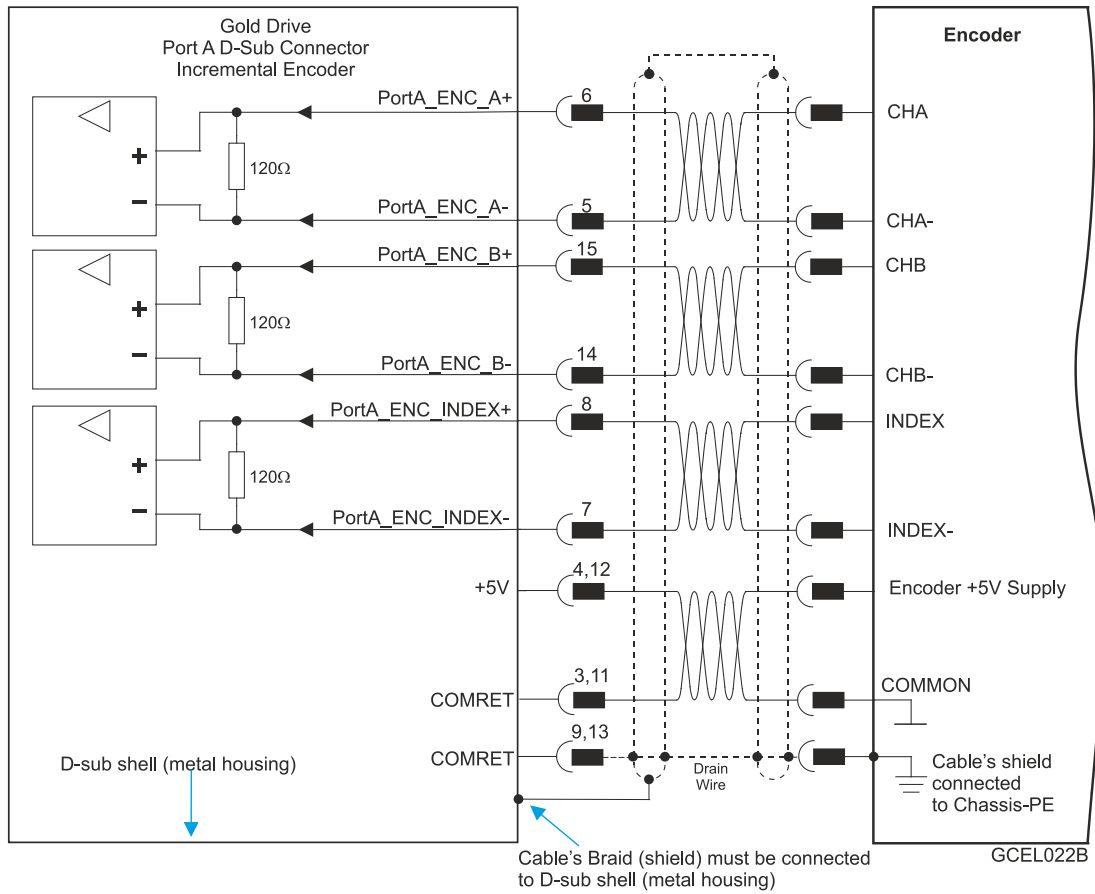


Figure 14: Port A D-Type Incremental Encoder Input – Recommended Connection Diagram

### 6.6.2. Hall Sensor

The following figure describes the connections at Port A for the Hall Sensor.

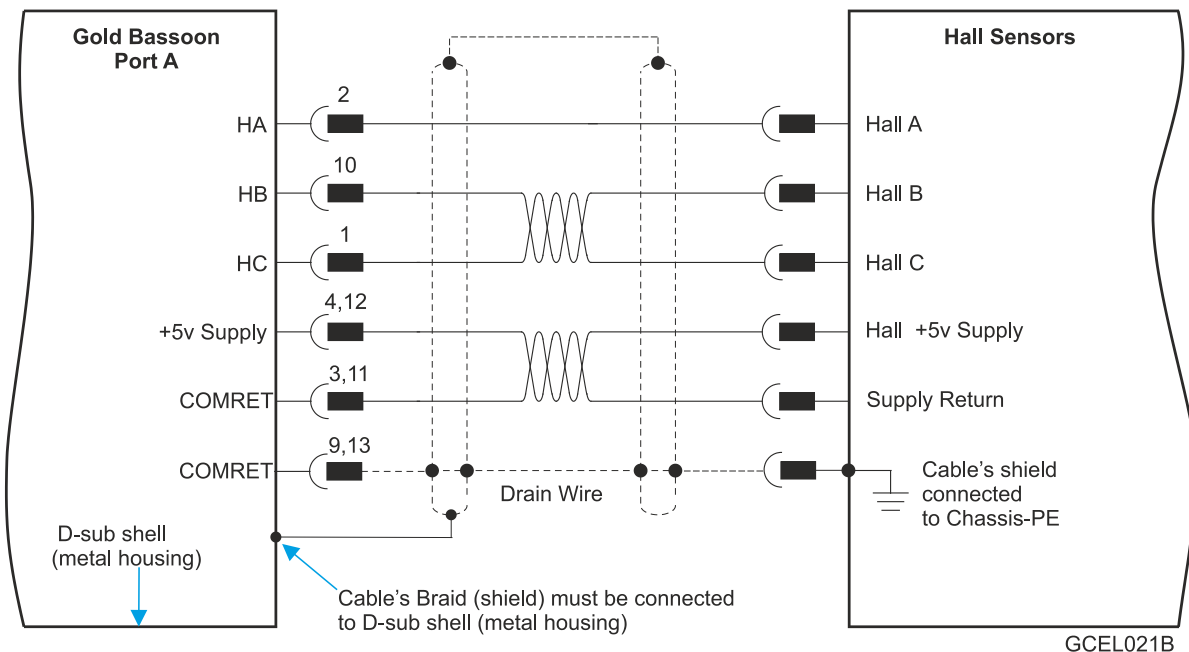
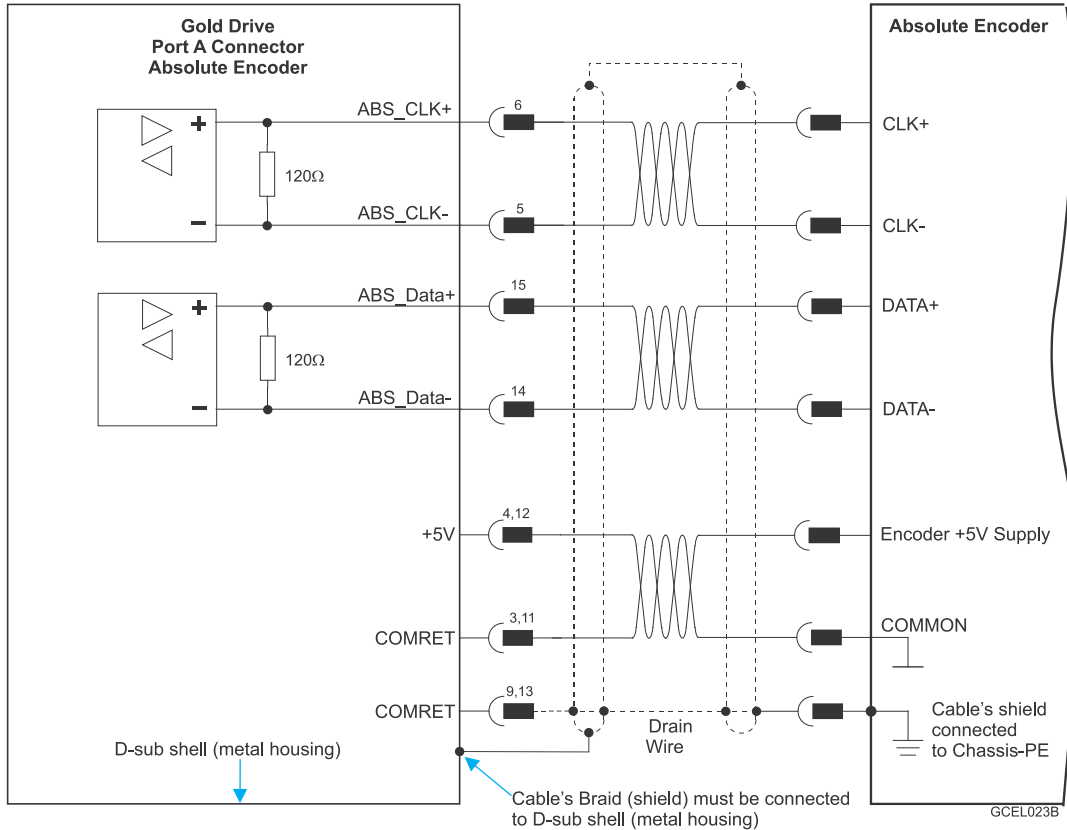


Figure 15: Hall Sensor Connection Diagram

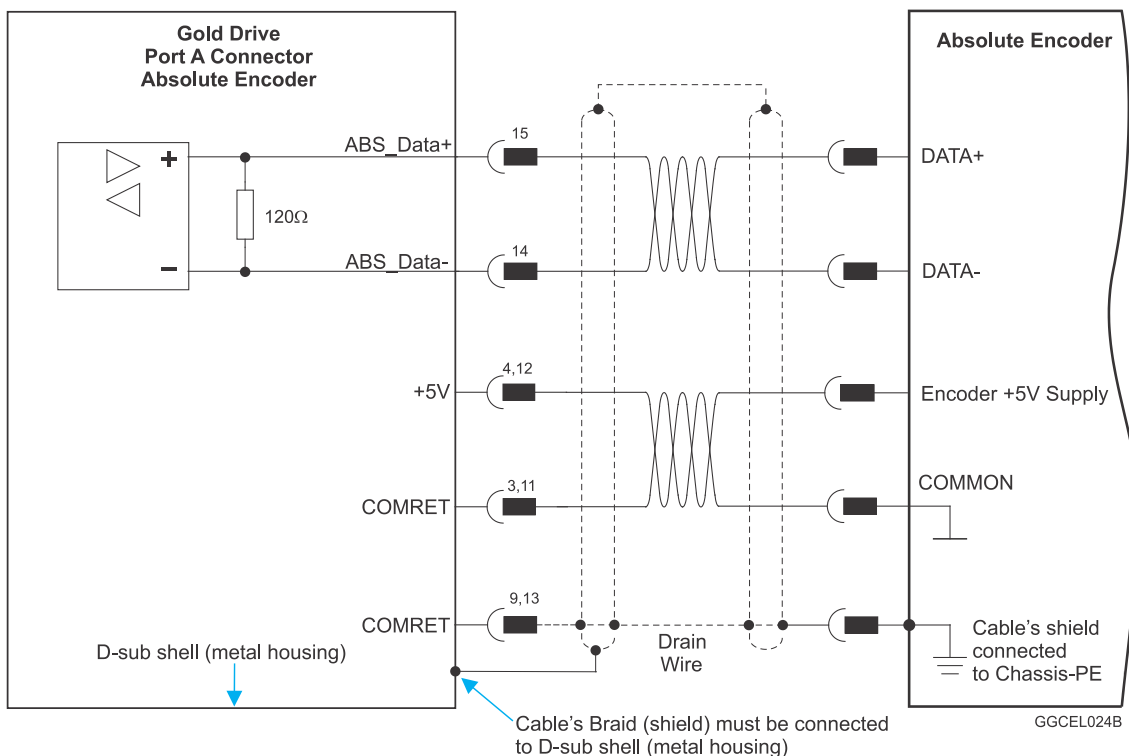


### 6.6.3. Absolute Serial Type Encoder

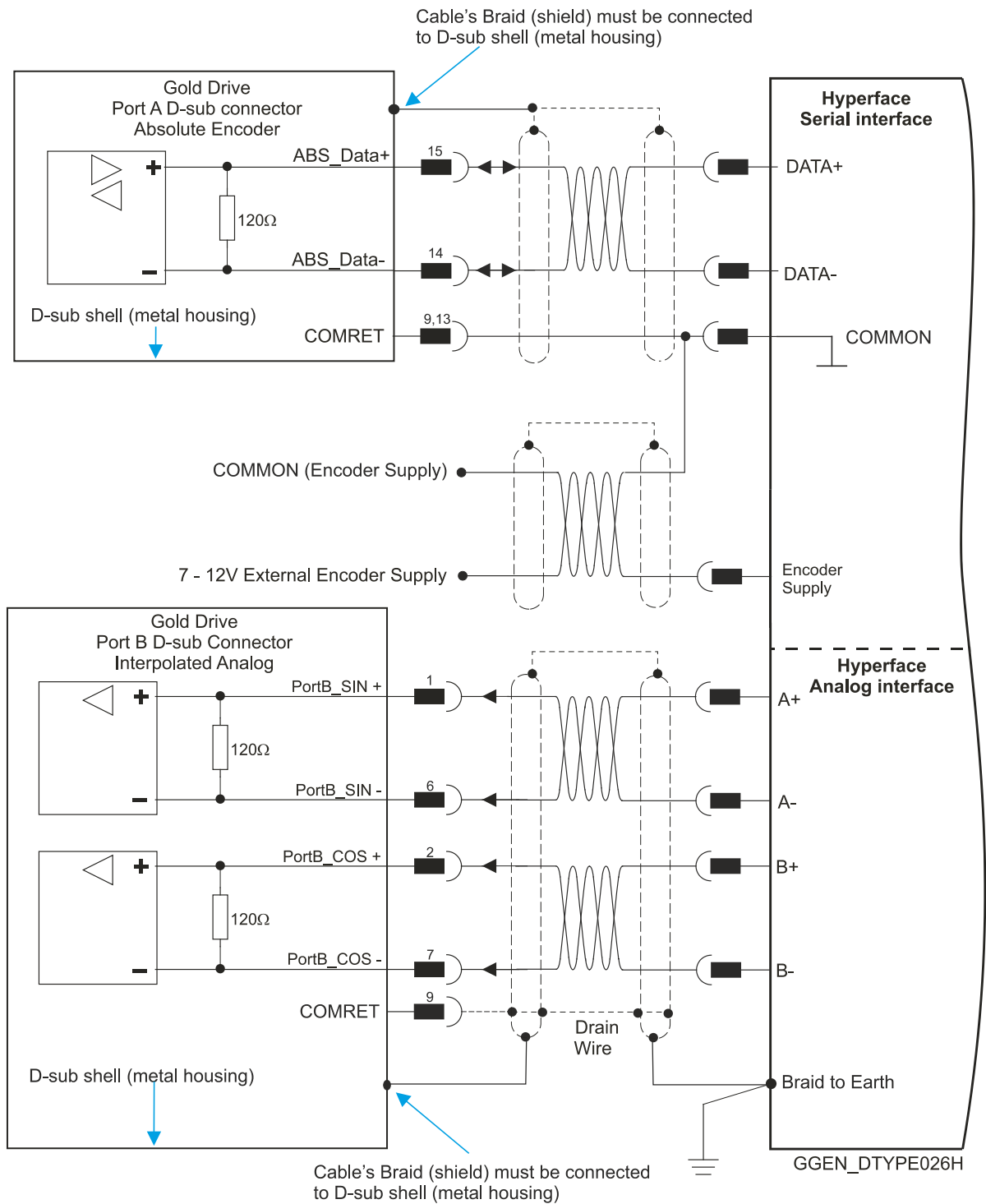
The following figures describe the connections at Port A for the Absolute Serial type encoders.



**Figure 16: Absolute Serial Encoder – Recommended D-Type Connection Diagram for EnDAT, Biss, and SSI**



**Figure 17: Absolute Serial Encoder – Recommended D-Type Connection Diagram for Sensors Supporting Data Line Only (NRZ types, e.g., Panasonic / Mitutoyo / Sanyo Danki / Tamagawa)**



**Figure 18: Absolute Serial Encoder – Recommended D-Type Connection Diagram for Stegmann Hiperface**



## 6.7. Port B (P2)

See Section 10.4 in the in the MAN-G-Panel Mounted Drives Hardware manual for full details.

Port B		Incremental or Interpolated Analog Encoder	Resolver	
		<b>G-CELXXX/YYYYEEA</b>	<b>G-CELXXX/YYYYERA</b>	
Pin (P2)	Signal	Function	Signal	Function
4	+5V	Encoder +5V supply	NC	
5, 9	COMRET	Common return	COMRET	Common return
1	PortB_ENC_A+/SIN+	Incremental Encoder A+ / Sine+	SIN+	Sine+
6	PortB_ENC_A-/SIN-	Channel A- / Sine-	SIN-	Sine-
2	PortB_ENC_B+/COS+	Channel B+ / Cosine+	COS+	Cosine+
7	PortB_ENC_B-/COS-	Channel B- / Cosine-	COS-	Cosine-
3	PortB_ENC_INDEX+	Index+	RESOLVER_OUT+	Vref f=1/TS, 50 mA Max.
8	PortB_ENC_INDEX-	Index -	RESOLVER_OUT-	Vref complement f= 1/TS, 50 mA Max.

### Pin Positions

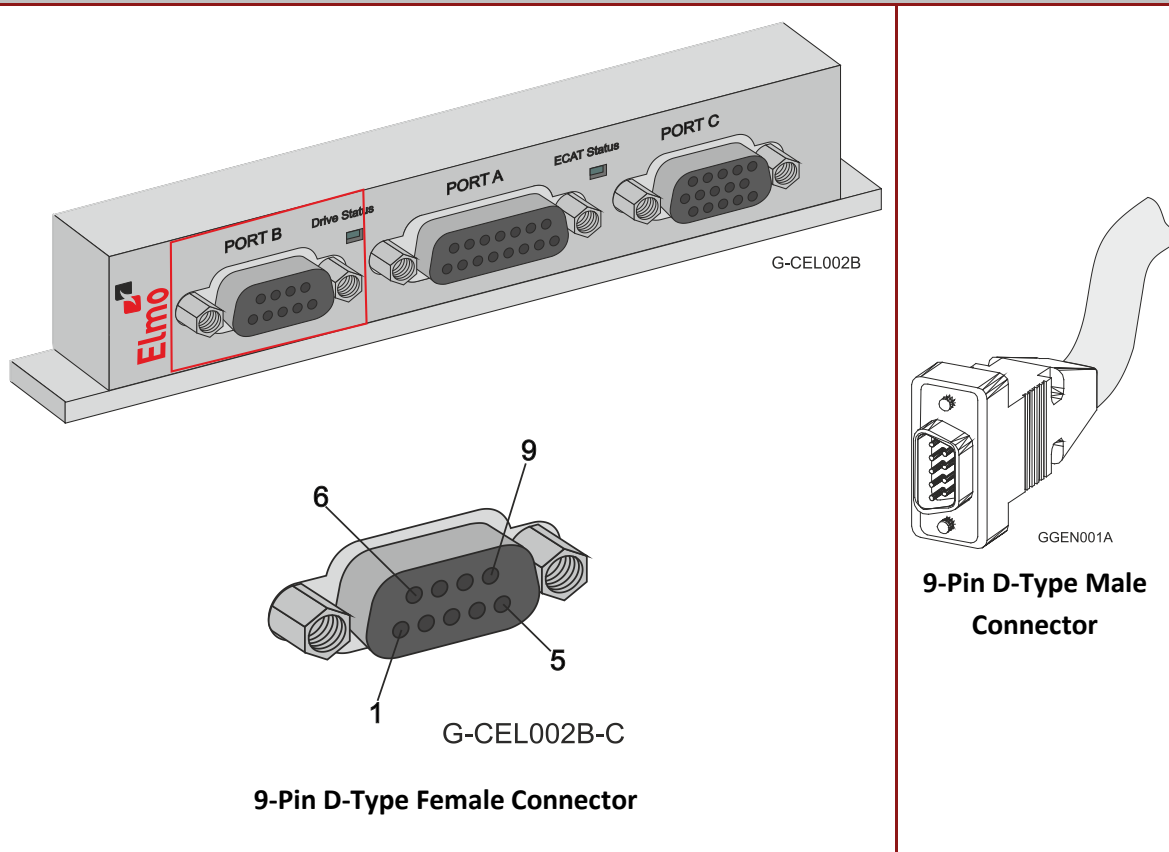


Table 8: Port B Pin Assignments



### 6.7.1. Incremental Encoder

The following figure describes the connections at Port B for the Incremental encoder.

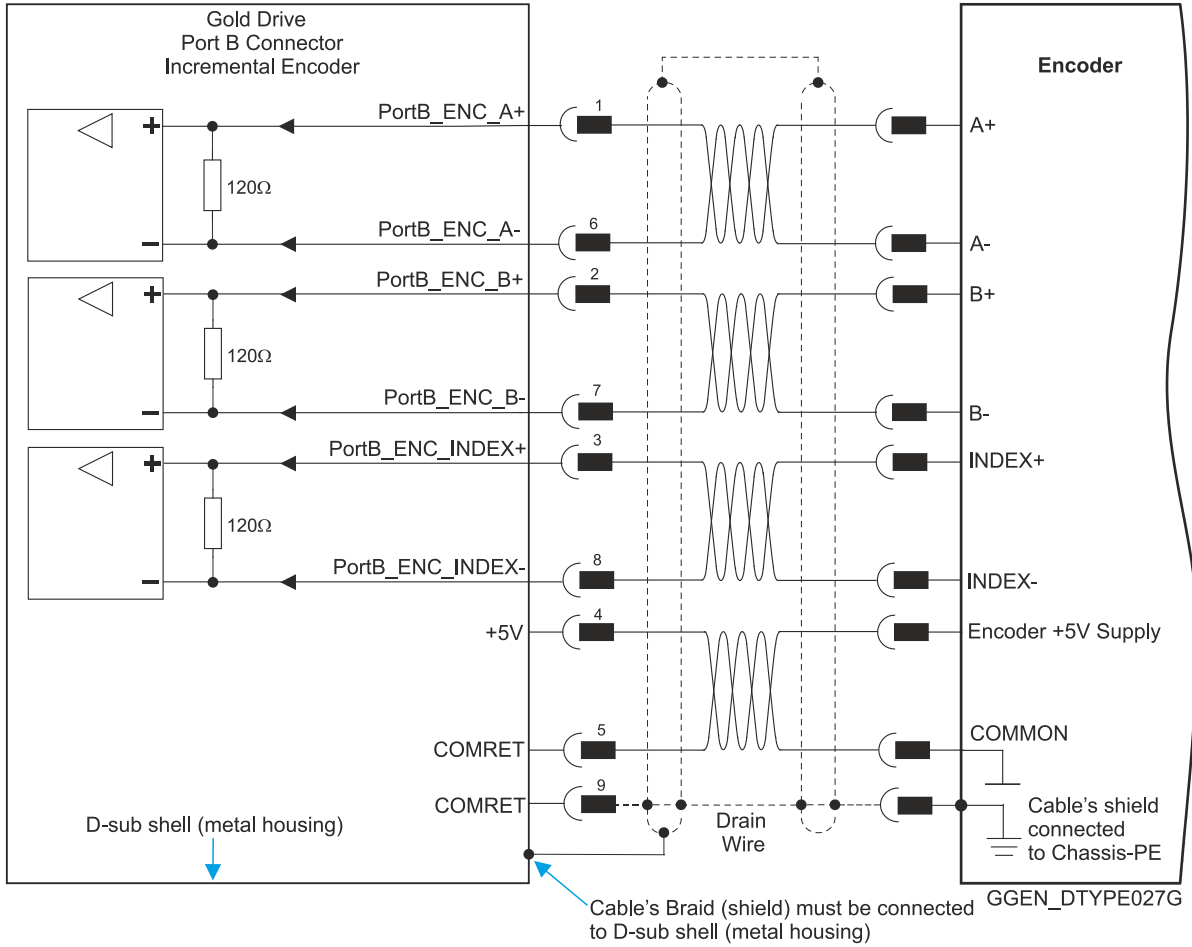


Figure 19: Port B Incremental Encoder Input – Recommended D-Type Connection Diagram



### 6.7.2. Interpolated Analog Encoder

The following figure describes the connections at Port B for the Interpolated Analog encoder.

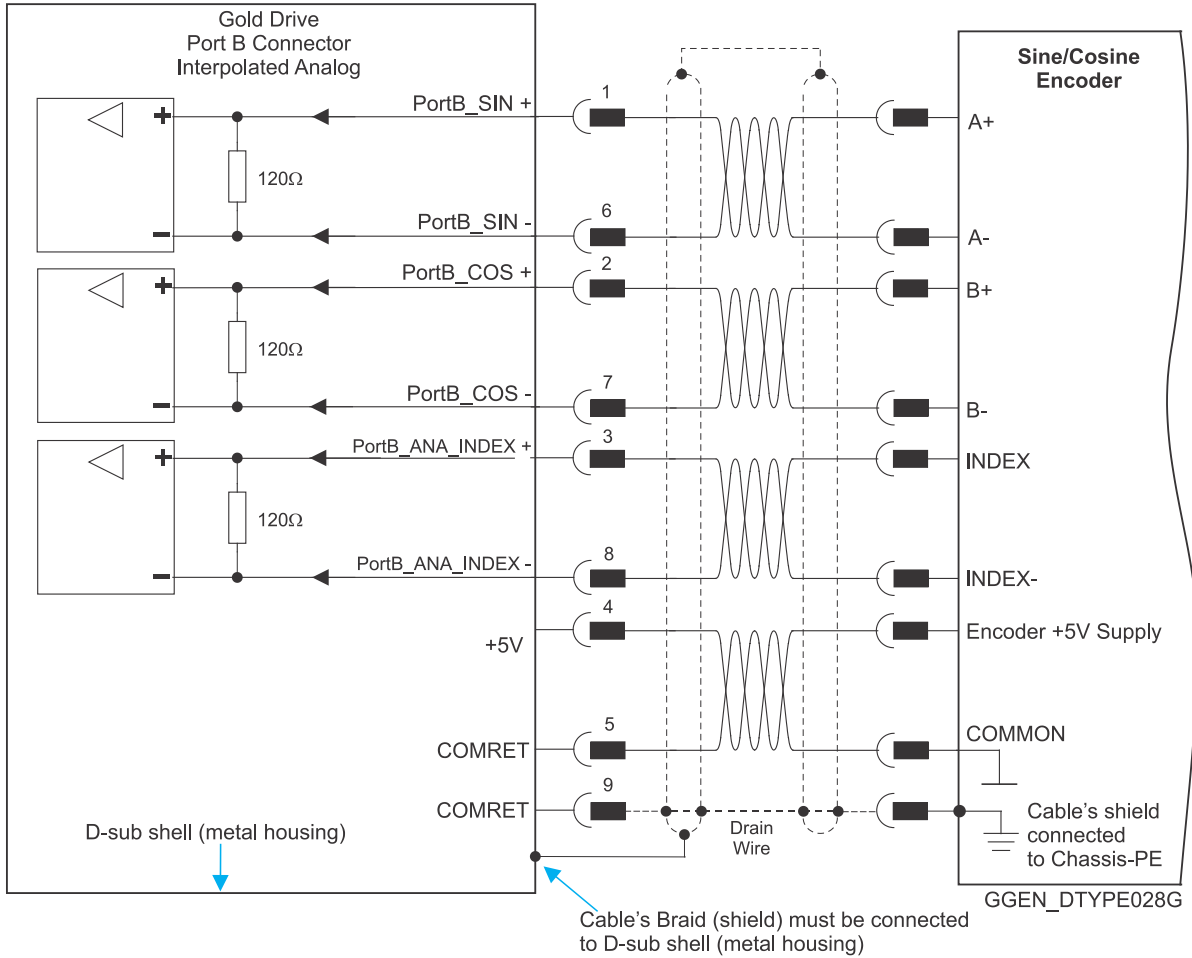
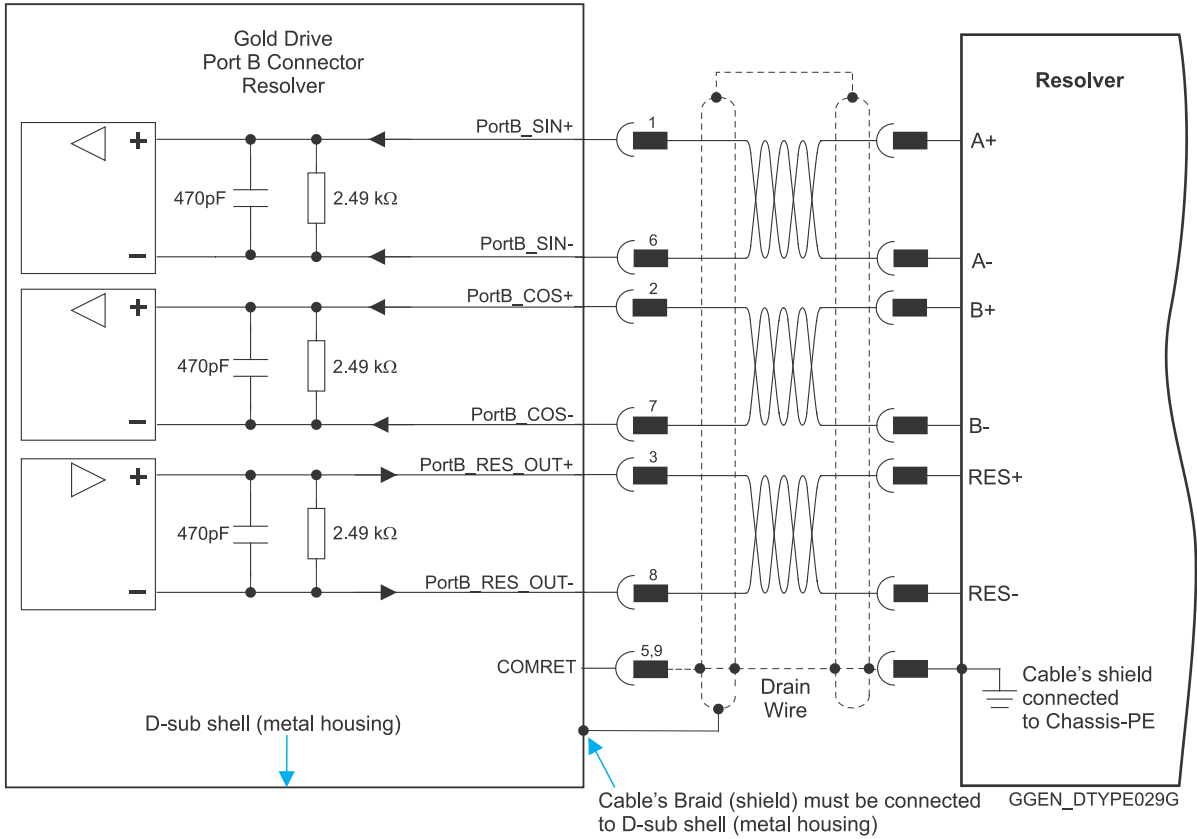


Figure 20: Port B - Interpolated Analog Encoder D-Type Connection Diagram



### 6.7.3. Resolver

The following figure describes the connections at Port B for the Resolver encoder.



**Figure 21: Port B – Resolver D-Type Connection Diagram**





## 6.8. Port C, Analog Input, and STO (P3)

The Port C connector includes the following functions:

- Port C: Refer to Sections 10.5 in the in the MAN-G-Panel Mounted Drives Hardware manual for full details
- STO: See Chapter 9 in the in the MAN-G-Panel Mounted Drives Hardware manual for full details.
- Analog input: See Section 11.2 in the in the MAN-G-Panel Mounted Drives Hardware manual for full details.

Pin (P3)	Signal	Function
1	PortC_ENCO_A+	Buffered Channel A+ output/Pulse+/PWM+
2	PortC_ENCO_A-	Buffered Channel A- output / Pulse- / PWM-
3	PortC_ENCO_B+	Buffered Channel B+ output / Dir+
4	PortC_ENCO_B-	Buffered Channel B- output / Dir-
5	PortC_ENCO_Index+	Buffered Channel INDEX+ output
6	STO1	STO 1 input (default 24 V)
7, 12	STO_RET	STO signal return
8	Reserved	Reserved
9	COMRET	Common return
10	PortC_ENCO_Index-	Buffered Channel INDEX- output
11	STO2	STO 2 input (default 24 V)
13	ANALRET	Analog Input Return
14	ANALOG1-	Analog input 1-
15	ANALOG1+	Analog input 1+



### Pin Positions

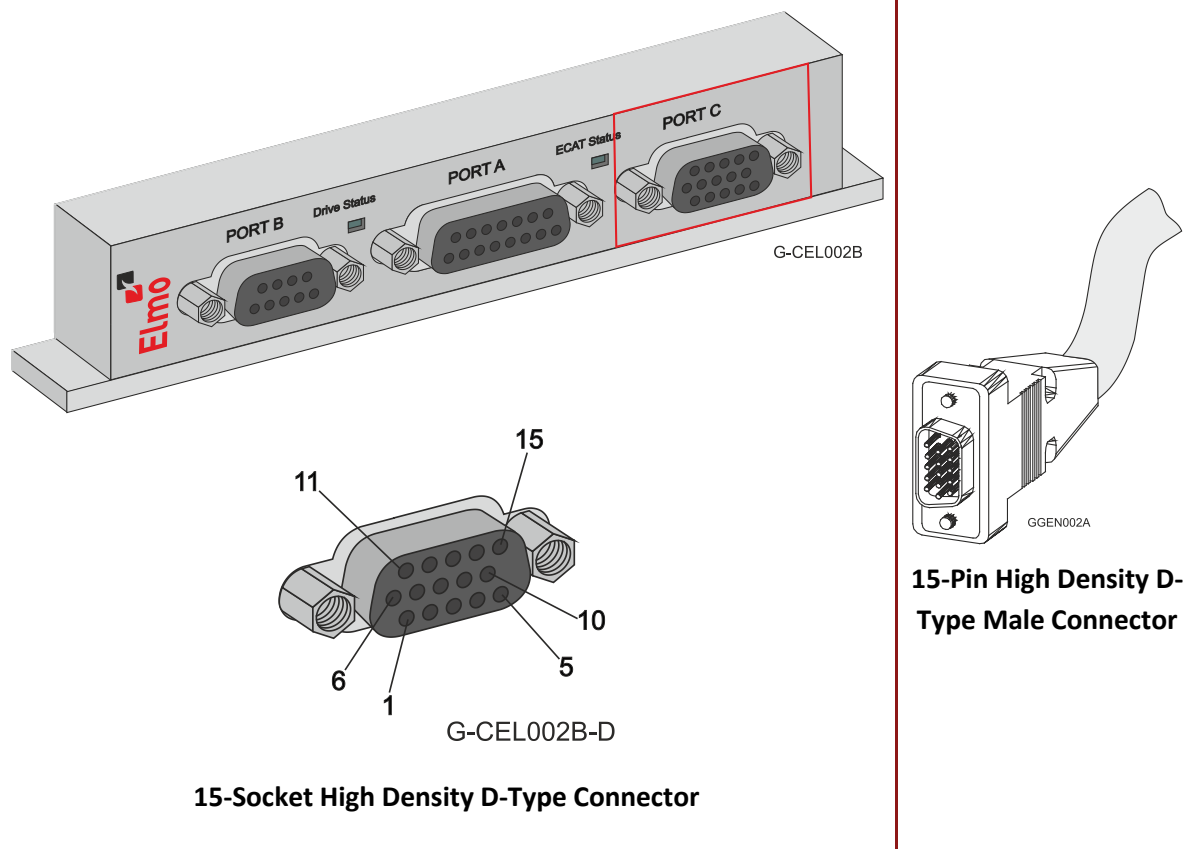


Table 9: Port C Pin Assignments



### 6.8.1. Port C

The following figure describes the connections at Port C for the Emulated Encoder Differential.

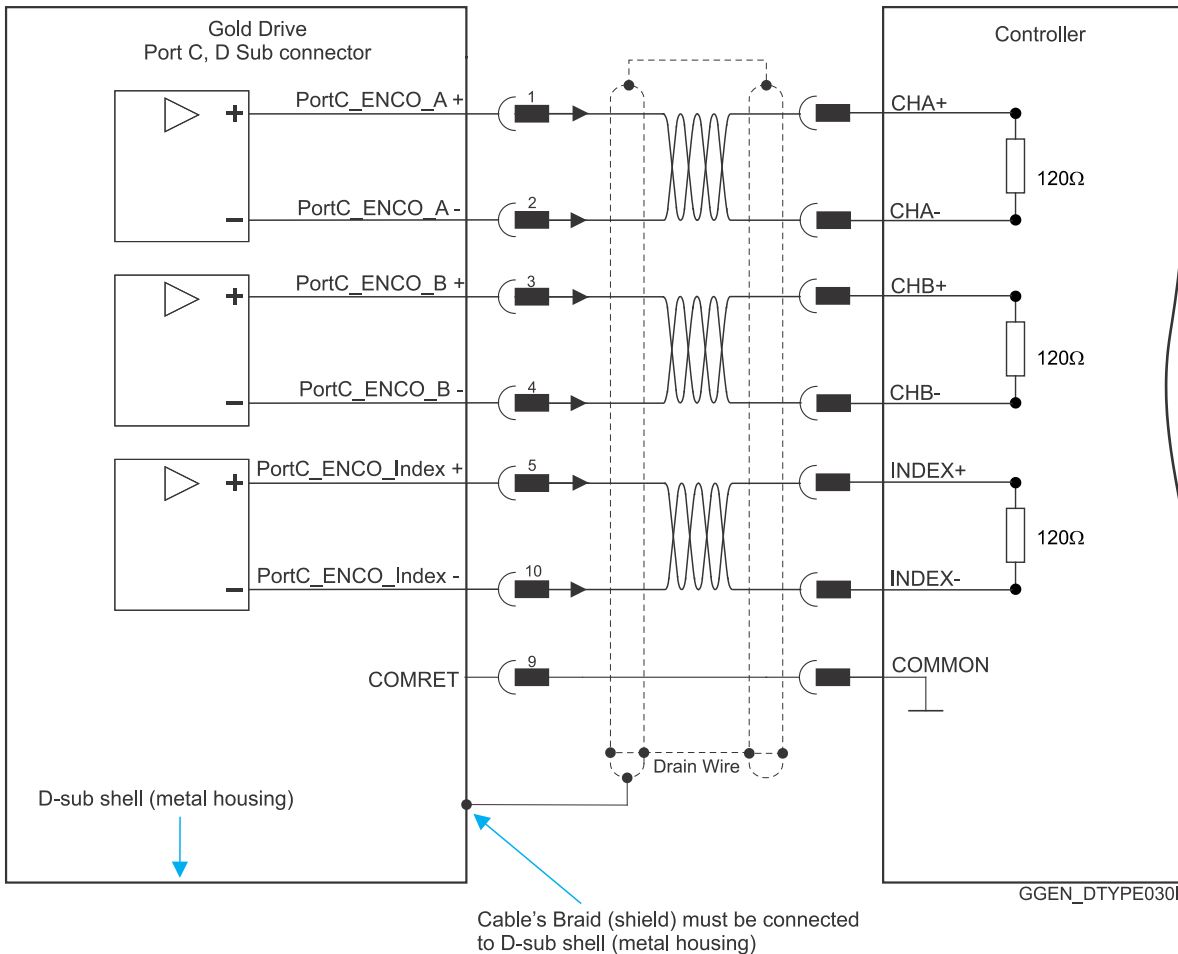


Figure 22: Emulated Encoder Differential Output – Recommended D-Type Connection Diagram

### 6.8.2. Analog Input

The following circuit describes the internal interface of the Analog input.

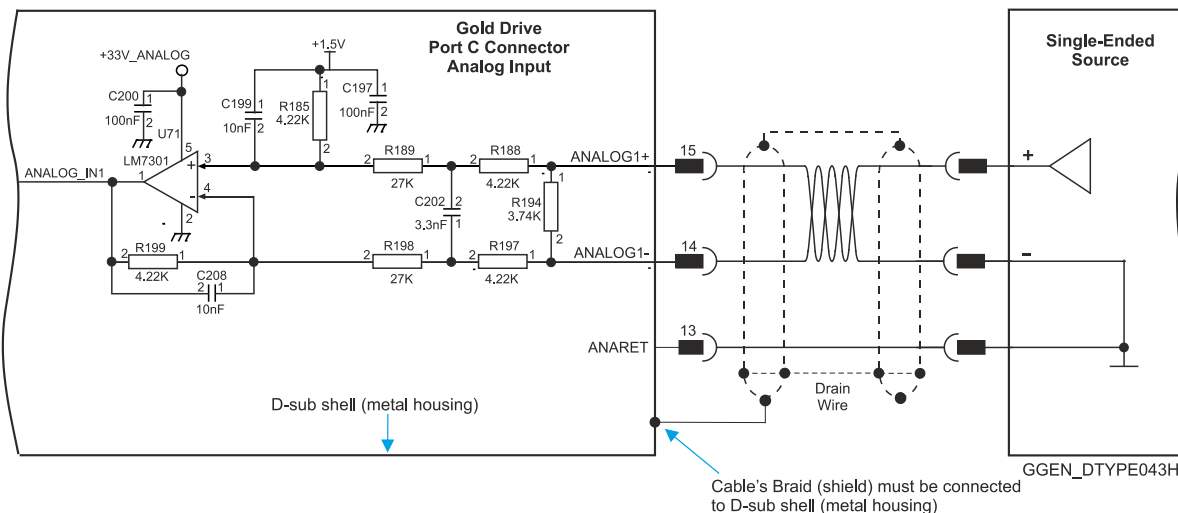


Figure 23: Differential Analog D-Type Input



### 6.8.3. STO

The following circuits describe the STO wiring options.

#### 6.8.3.1. Source Mode PLC Voltage Level

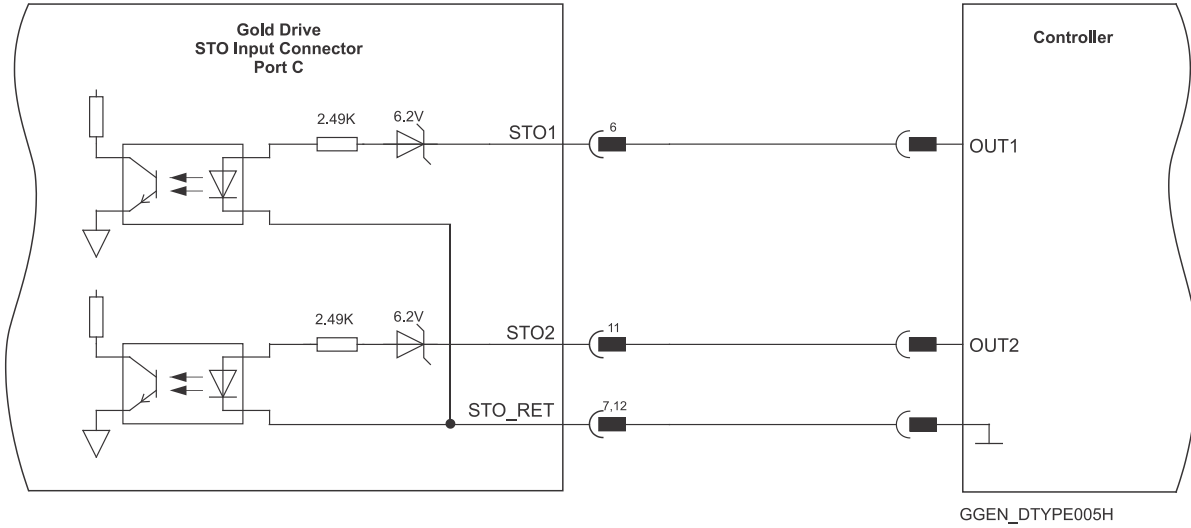


Figure 24: STO D-Type Input Connection – PLC Source Option

#### 6.8.3.2. TTL Mode TTL Voltage Level

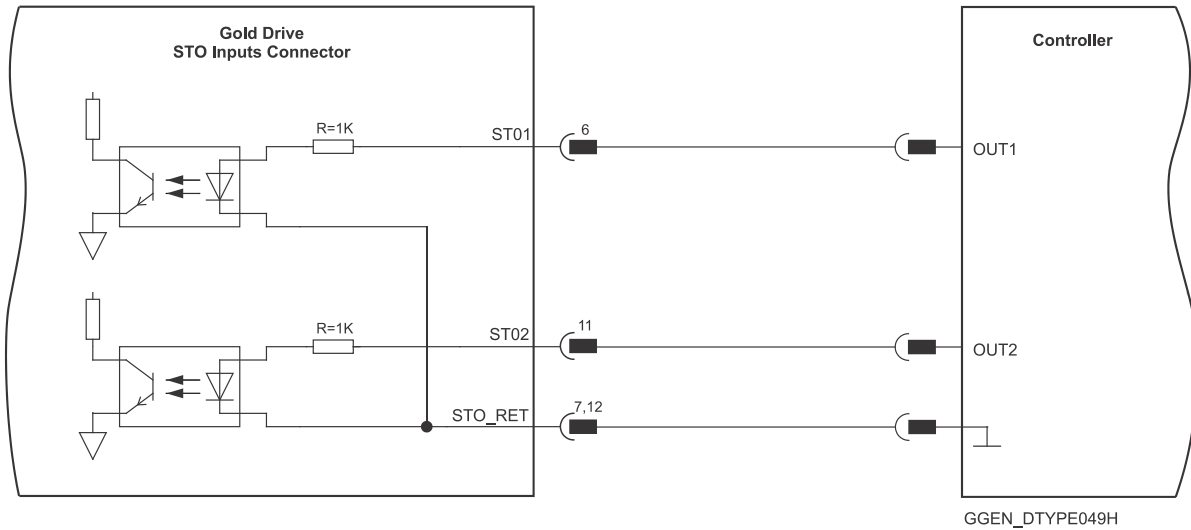


Figure 25: STO Input Connection – TTL Option



### 6.8.3.3. SINK Mode – PLC Voltage Level

Refer to the diagrams below for the PLC Sink option connections which is not fully certified for STO.  
**This option is not recommended for new designs.**

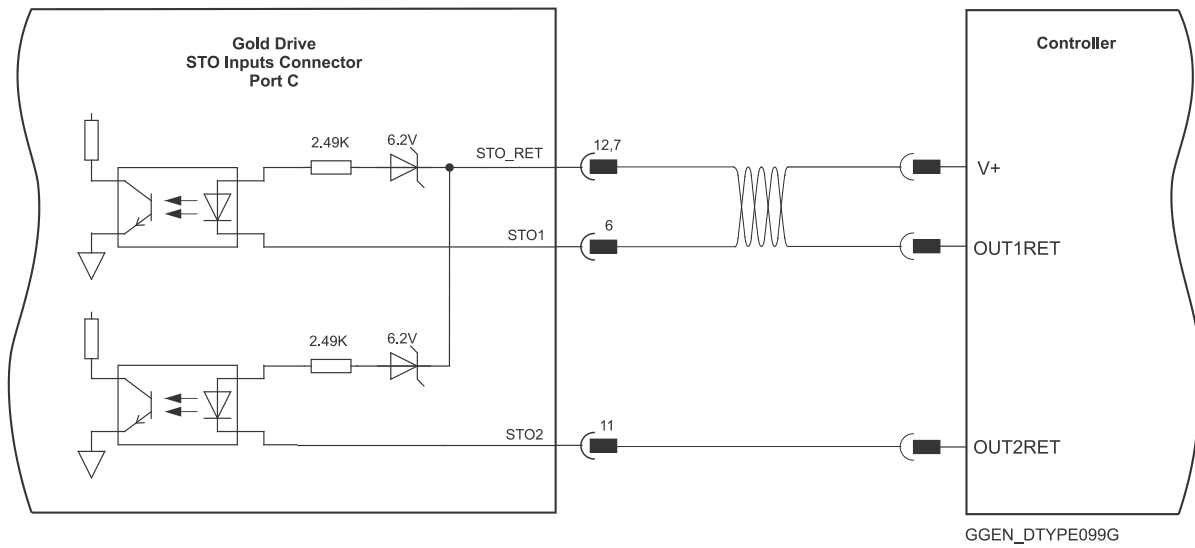


Figure 26: STO D-Type Input Connection – Sink Option



## 6.9. Digital Inputs and Outputs (P4)

Refer to Chapter 11 in the in the MAN-G-Panel Mounted Drives Hardware manual for full details.

I/O Pins (P4)	Signal	Function
1	IN1	Programmable digital input 1 (event capture, home, general purpose, RLS, FLS, INH, PWM & direction input, pulse & direction input)
2	IN2	Programmable digital input 2 (event capture, home, general purpose, RLS, FLS, INH, PWM & direction input, pulse & direction input)
7	IN3	Programmable digital input 3 (event capture, home, general purpose, RLS, FLS, INH, PWM & direction input, pulse & direction input)
8	IN4	Programmable digital input 4 (event capture, home, general purpose, RLS, FLS, INH, PWM & direction input, pulse & direction input)
11	IN5	Programmable digital input 5 (event capture, home, general purpose, RLS, FLS, INH, PWM & direction input, pulse & direction input)
12	IN6	Programmable digital input 6 (event capture, home, general purpose, RLS, FLS, INH, PWM & direction input, pulse & direction input)
6	INRET1-6	Programmable inputs 1 to 6 return for the standard version Programmable positive input 1 to 6 for the Sink version
3	OUT1	Programmable output 1
4	OUT2	Programmable output 2
5	OUT3	Programmable output 3
13	OUT4	Programmable output 4
10, 15	VDD	Supply for out 1-4
9, 14	VDDRET	Supply return for out 1-4



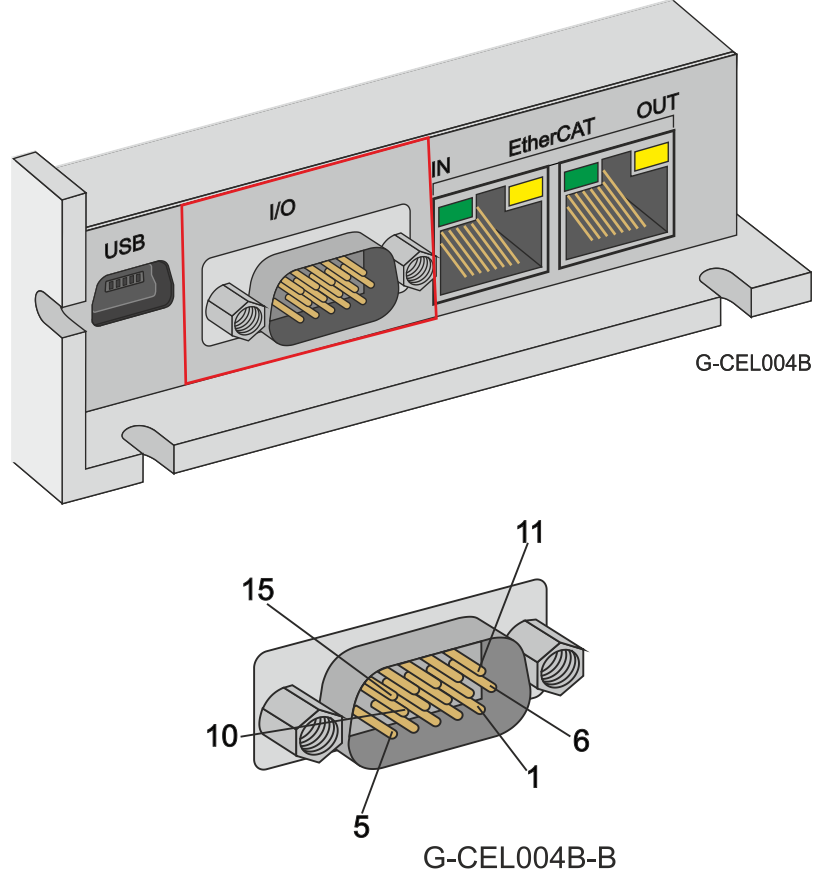
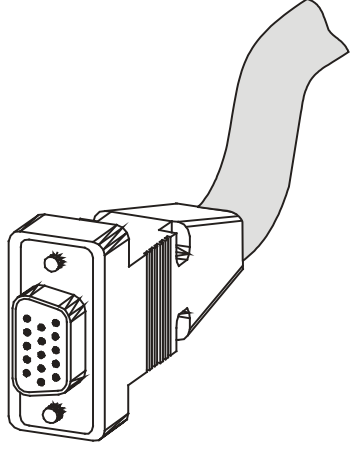
I/O Pins (P4)	Signal	Function
<b>Pin Positions</b>		
 <p data-bbox="925 672 1045 705">G-CEL004B</p> <p data-bbox="654 1153 853 1198">G-CEL004B-B</p> <p data-bbox="375 1220 917 1265"><b>15-Pin High Density D-Type Male Connector</b></p>		 <p data-bbox="1117 1008 1444 1086"><b>15-Pin High Density D-Type Female Connector</b></p>

Table 10: I/O Port Pin Assignments



### 6.9.1. Digital Input and Output TTL Mode

The following figure describes the connections at the I/O Port for the Digital Input and Output TTL Mode.

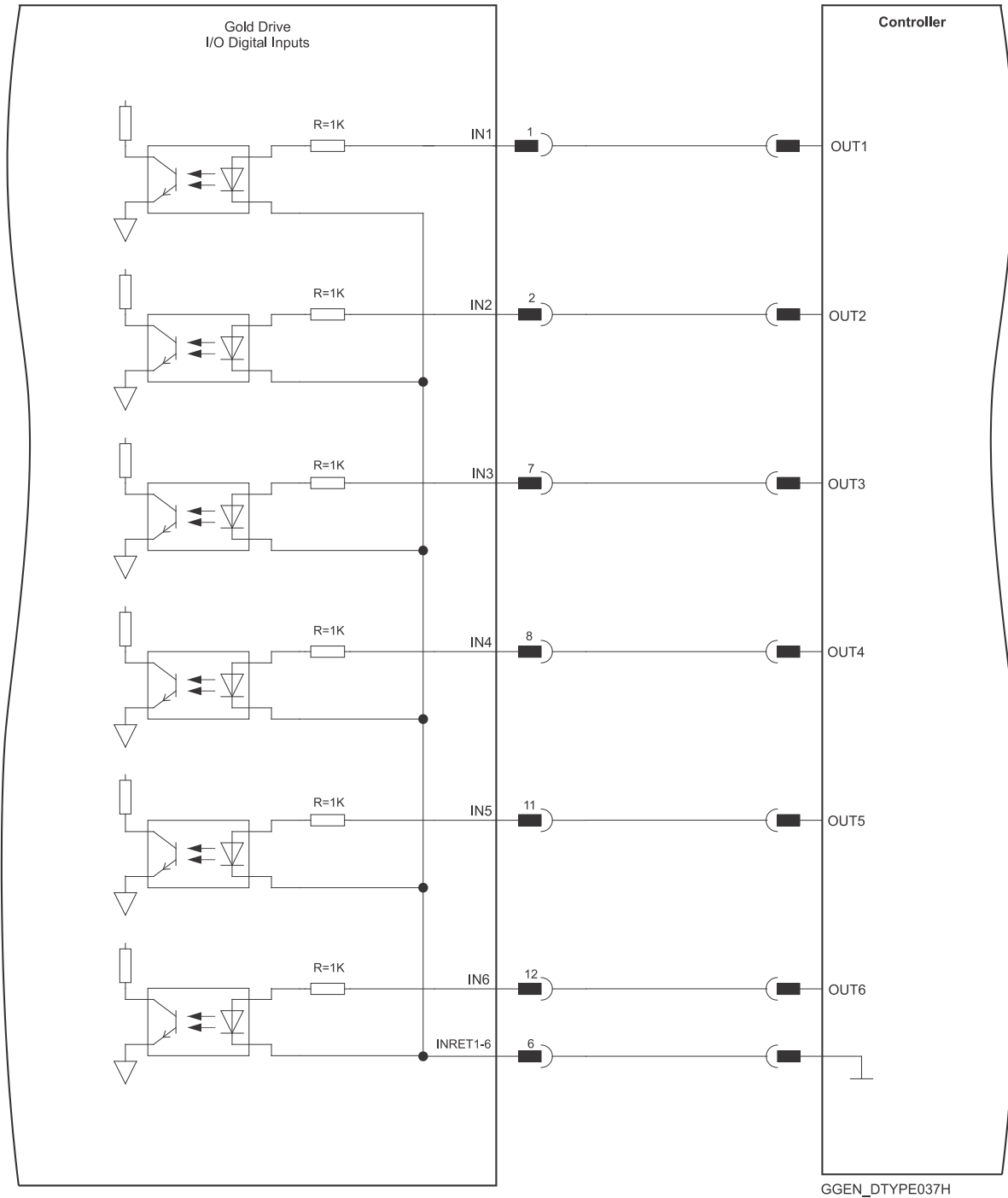


Figure 27: Digital Input TTL Mode D-Type Connection Diagram



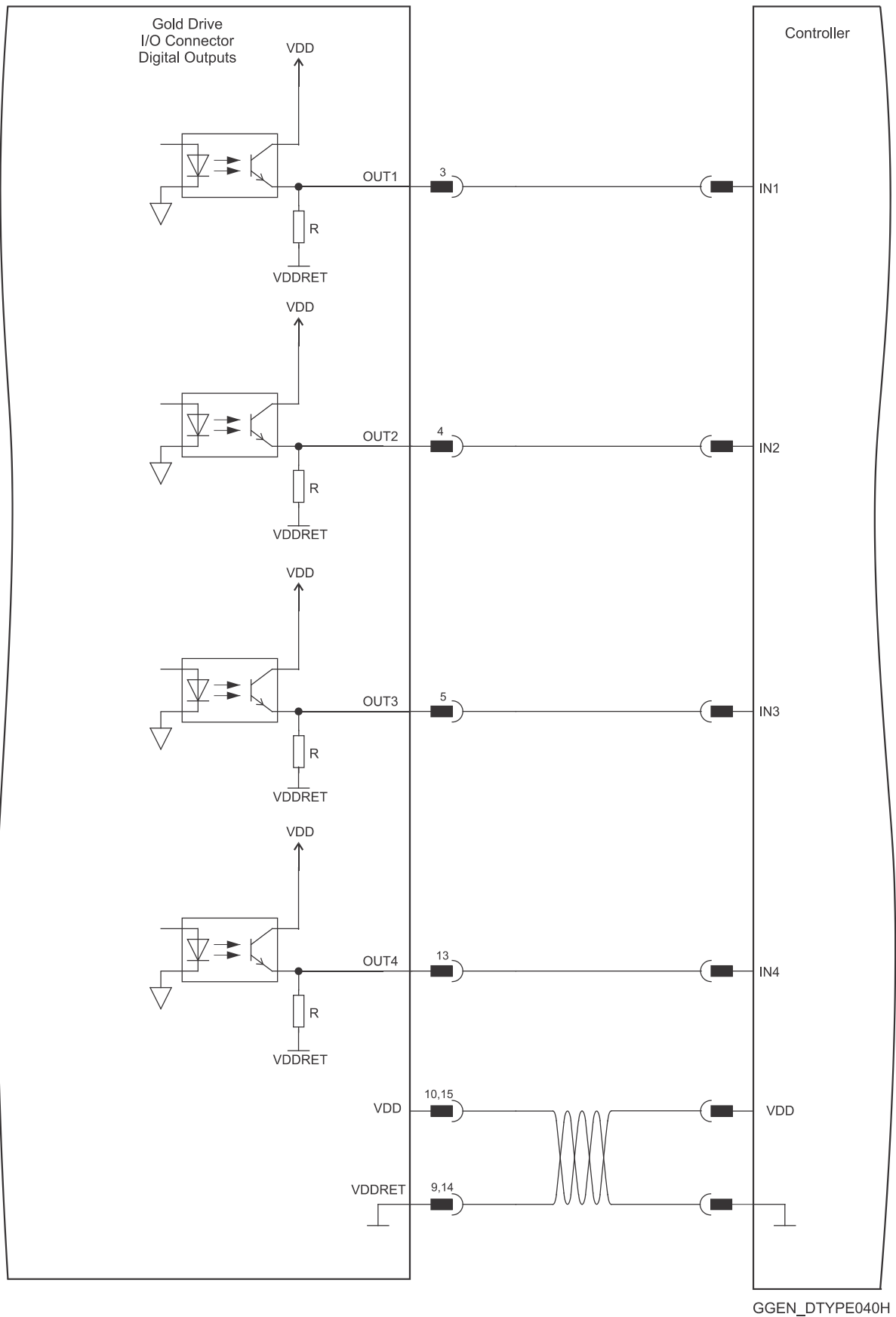


Figure 28: Digital Output D-Type Connection Diagram – TTL Option



### 6.9.2. Digital Input and Output PLC Source Mode

The following figure describes the connections at the I/O Port for the Digital Input and Output PLC Mode.

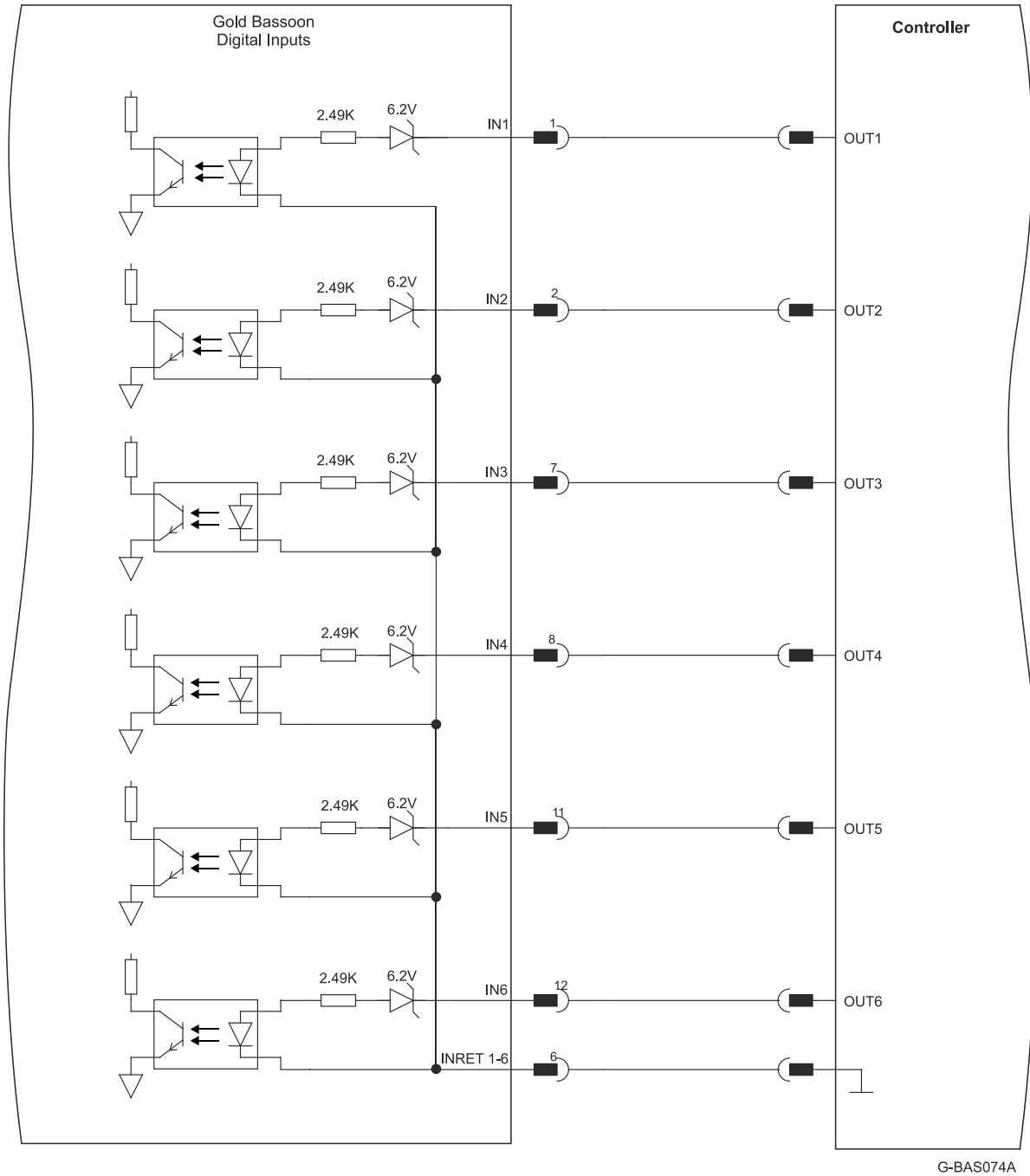
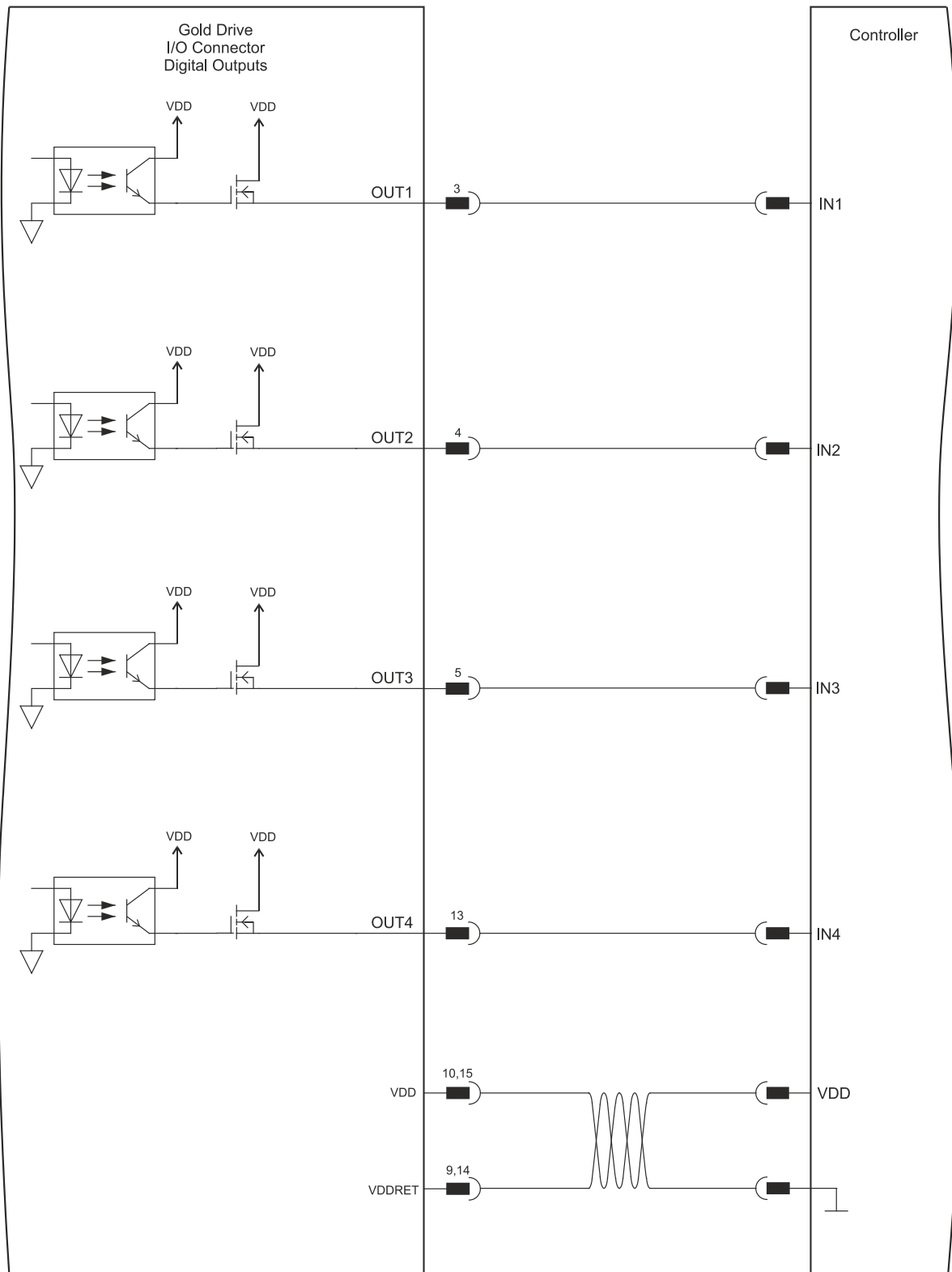


Figure 29: Digital Input D-Type Connection Diagram – Source PLC Option



GGEN\_DTYPE0411

Figure 30: Digital Output D-Type Connection Diagram – Source PLC Option



### 6.9.3. Digital Input and Output Sink Mode

The following figure describes the connections at the I/O Port for the Digital Input and Output Sink Mode.

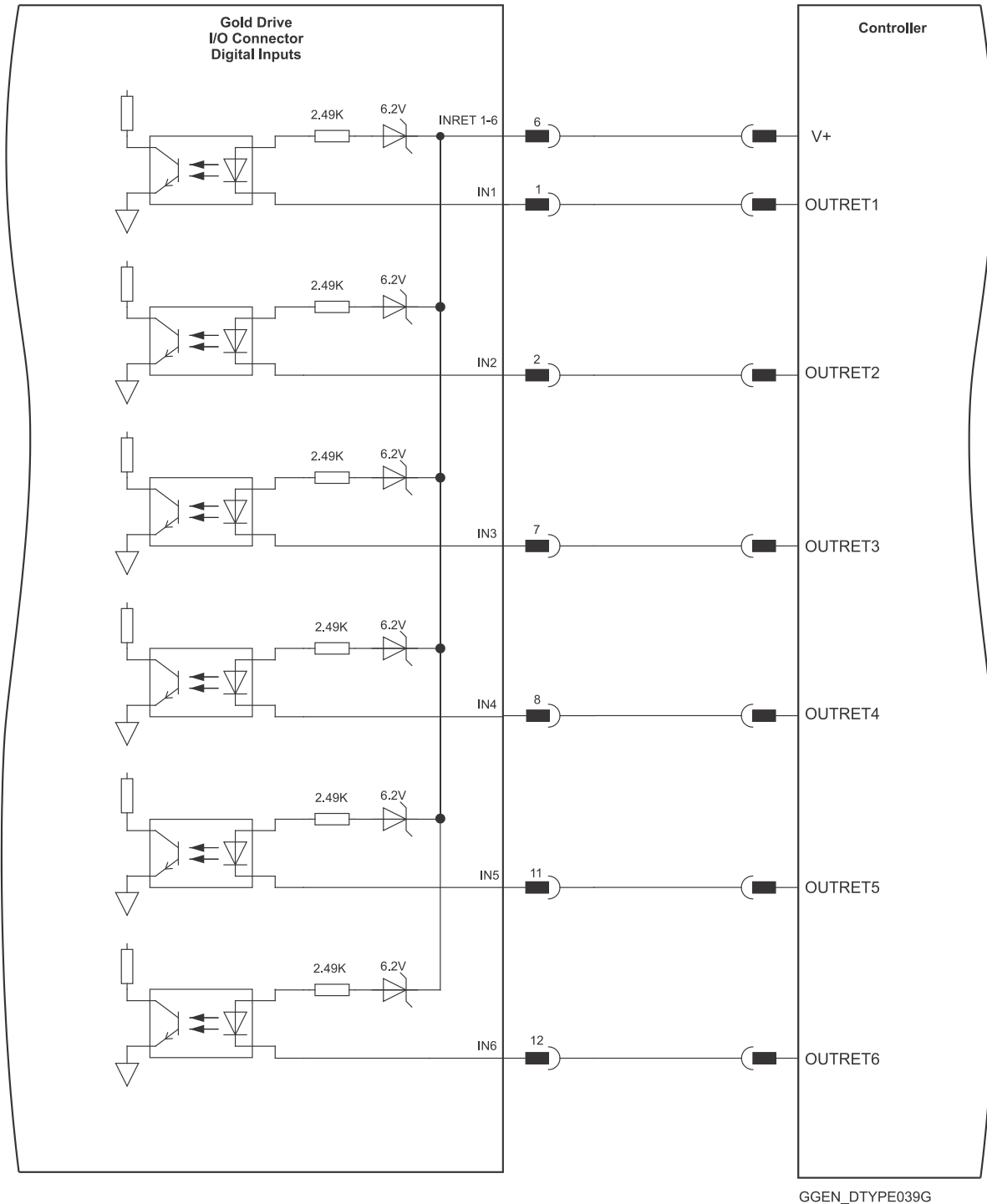


Figure 31: Digital Input Sink Mode – PLC voltage level D-Type Connection Diagram

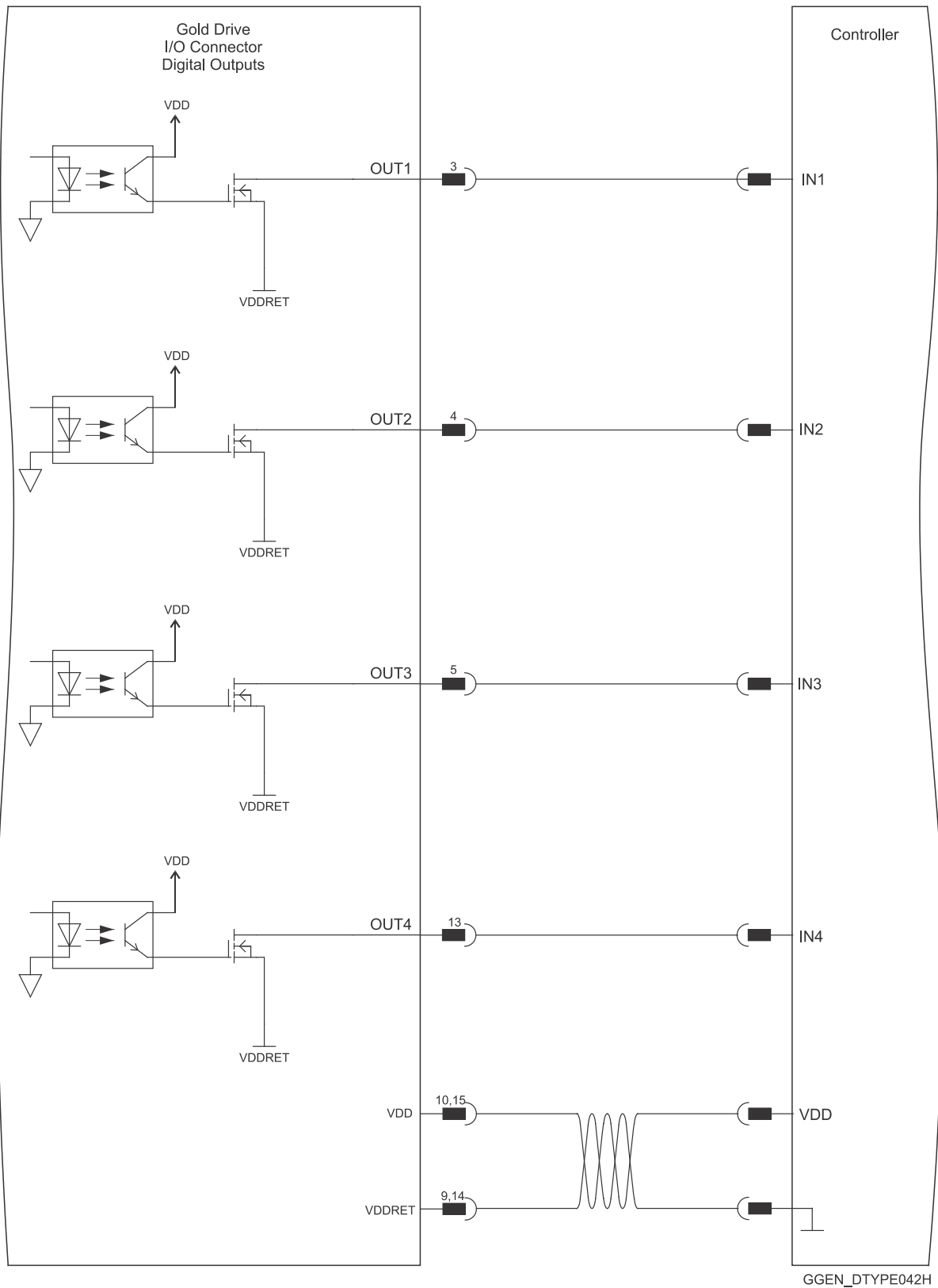


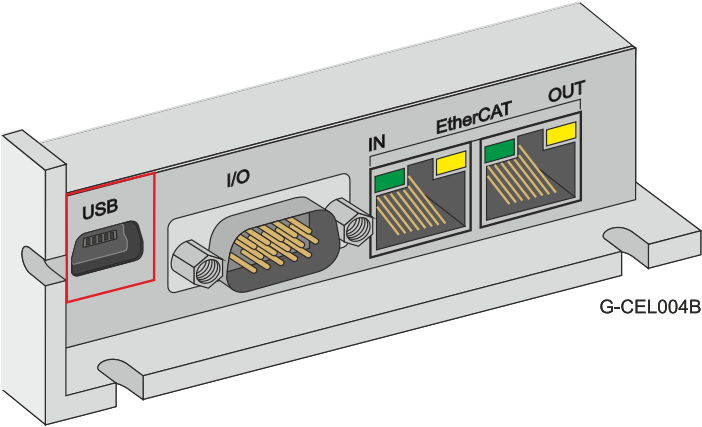
Figure 32: Digital Output as Sink Configuration D-Type Connection Diagram



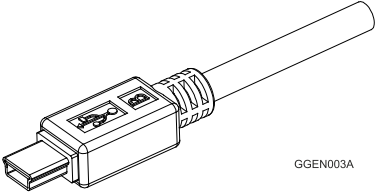
## 6.10. USB 2.0 (J22)

See Section 12.1 in the in the MAN-G-Panel Mounted Drives Hardware manual for full details.

Pin (J22)	Signal	Function
1	USB VBUS	USB VBUS 5V
2	USBD-	USB _N line
3	USBD+	USB _P line
4	N/A	N/A
5	USB COMRET	USB communication return



**USB Device Mini-B**



**USB Device Mini-B Plug**

Table 11: USB 2.0 Pin Assignments

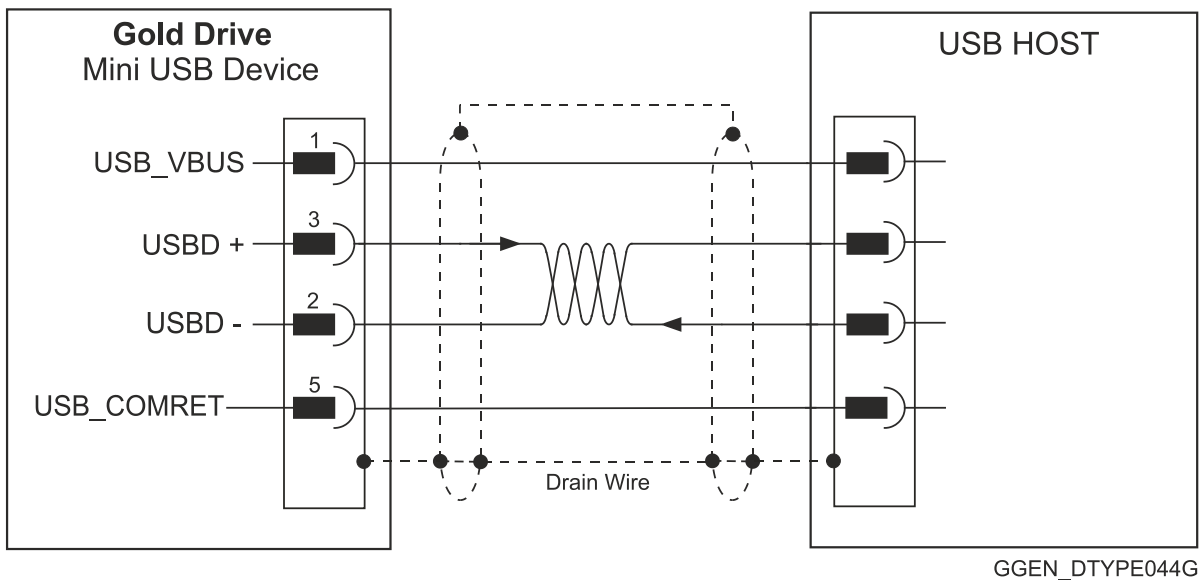


Figure 33: USB Network Diagram



## 6.11. EtherCAT Communications Version

Fieldbus communications are industrial network protocols for real-time distributed control that allows connection of servo drives.

### 6.11.1. EtherCAT IN/Ethernet Pinouts

Refer to section 12.2 in the MAN-G-Panel Mounted Drives Hardware manual for more details.

Pin	Signal	Function
1	EtherCAT_IN_TX+/Ethernet_TX+	EtherCAT in transmit+/Ethernet transmit +
2	EtherCAT_IN_TX-/Ethernet_TX-	EtherCAT in transmit-/Ethernet transmit -
3	EtherCAT_IN_RX+/Ethernet_RX+	EtherCAT in receive+/Ethernet receive +
4/5	N/A	
6	EtherCAT_IN_RX-/Ethernet_RX-	EtherCAT in receive-/Ethernet receive -
7/8	N/A	

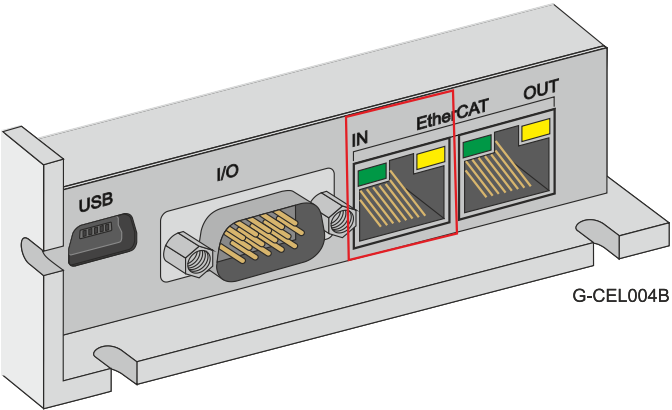
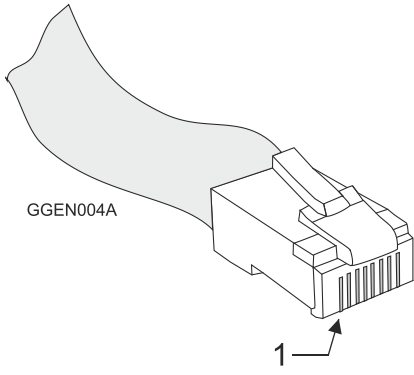
Pin Positions	
 <p><b>8-Pin RJ-45 – EtherCAT</b></p>	 <p><b>Standard Ethernet CAT5 Cable</b></p>

Table 12: EtherCAT In Pin Assignments



### 6.11.2. EtherCAT OUT

See Section 12.2 in the MAN-G-Panel Mounted Drives Hardware manual for the electrical diagram.

Pin	Signal	Function
1	EtherCAT_OUT_TX+	EtherCAT out transmit +
2	EtherCAT_OUT_TX-	EtherCAT out transmit -
3	EtherCAT_OUT_RX+	EtherCAT out receive +
4, 5	N/A	
6	EtherCAT_OUT_RX-	EtherCAT out receive -
7, 8	N/A	

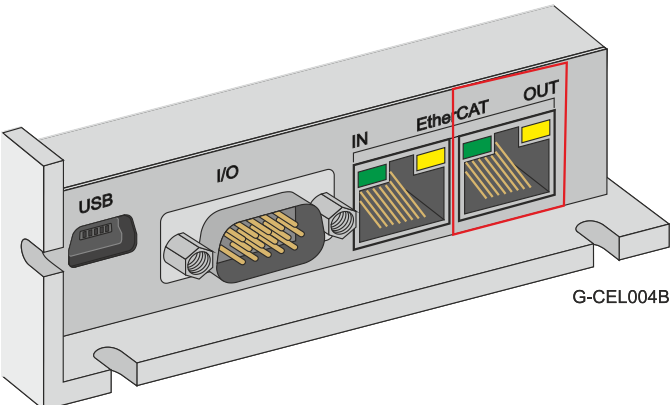
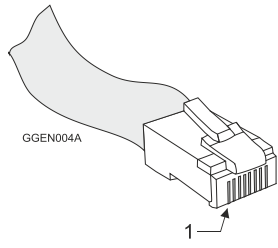
Pin Positions	
 <p><b>8-Pin RJ-45 – EtherCAT</b></p>	 <p><b>Standard Ethernet CAT5 Cable</b></p>

Table 13: EtherCAT Out Pin Assignments

### 6.11.3. EtherCAT Wiring

Figure 34 describes the wiring diagram for the EtherCAT connections.

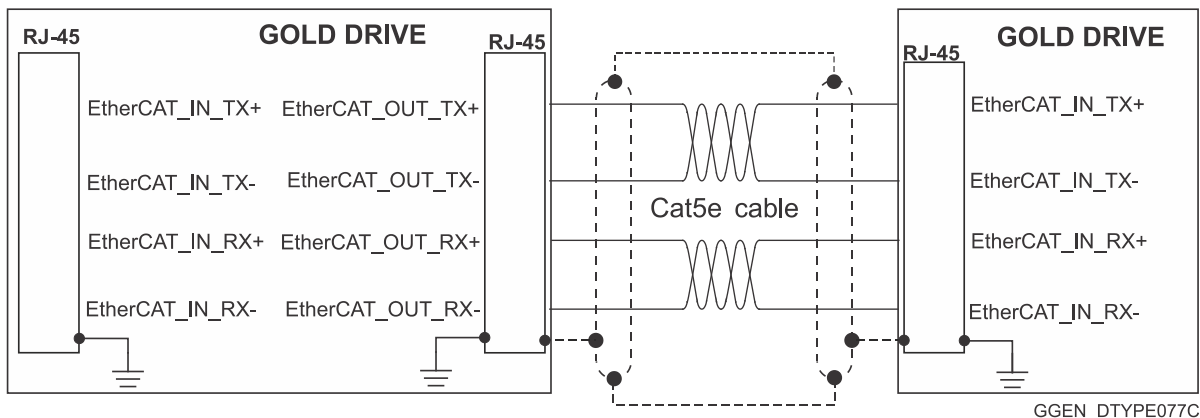


Figure 34: EtherCAT RJ-45 Connections





### 6.11.4. EtherCAT Link Indicators

The Gold Cello can serve as an EtherCAT slave device. For this purpose it has two RJ-45 connectors, which are designated as EtherCAT In and EtherCAT Out. Each of these RJ-45 connectors has two status LEDs, which are shown in Figure 35.

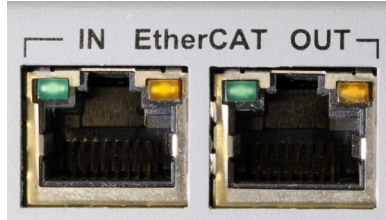


Figure 35: Ethernet Connector LEDs

The green LED is the link/activity indicator. It shows the state of the applicable physical link and the activity on that link. The amber LED is the speed indicator. It shows the speed of the connection on the Ethernet line. Refer to the section 12.2.1.2 in the document; MAN-G-Panel Mounted Drives Hardware manual.

### 6.11.5. EtherCAT Status Indicator

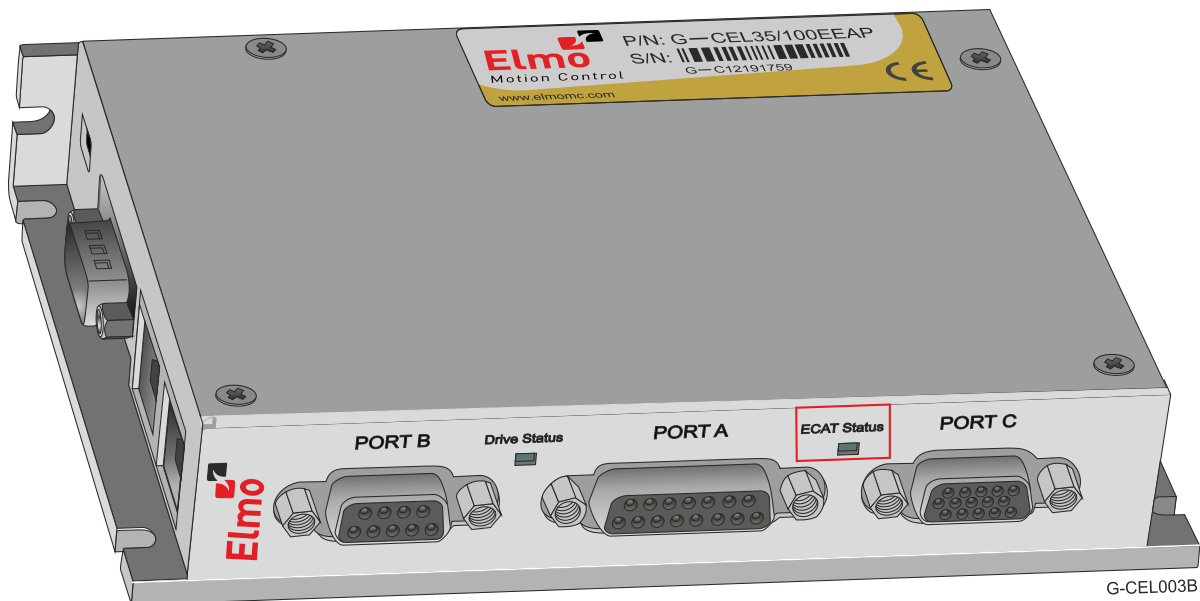


Figure 36: EtherCAT Status LED

The EtherCAT status indicator is a red/green dual LED. It combines run indication (when it is green) and error indication (when it is red) of the EtherCAT device. For further details, see the EtherCAT Manual.



## 6.12. CAN Communication Version

Fieldbus communications are industrial network protocols for real-time distributed control that allows connection of servo drives. The Gold Cello supports the following CAN fieldbus type industrial network protocol:

Fieldbus Type	Product Number
CAN	G-CEL XX/YYYYSXX

See Section 12.4 in the MAN-G-Panel Mounted Drives Hardware manual for the electrical diagram.

Pin	Signal	Function
1	CAN_H	CAN_H bus line (dominant high)
2	CAN_L	CAN_L bus line (dominant low)
3	COMRET (CAN_RET)	CAN Return
4, 5	N/A	—
6	CAN_SHLD	Shield, connected to the RJ plug cover
7	COMRET (CAN_RET)	CAN Return
8	N/A	—

### Pin Positions

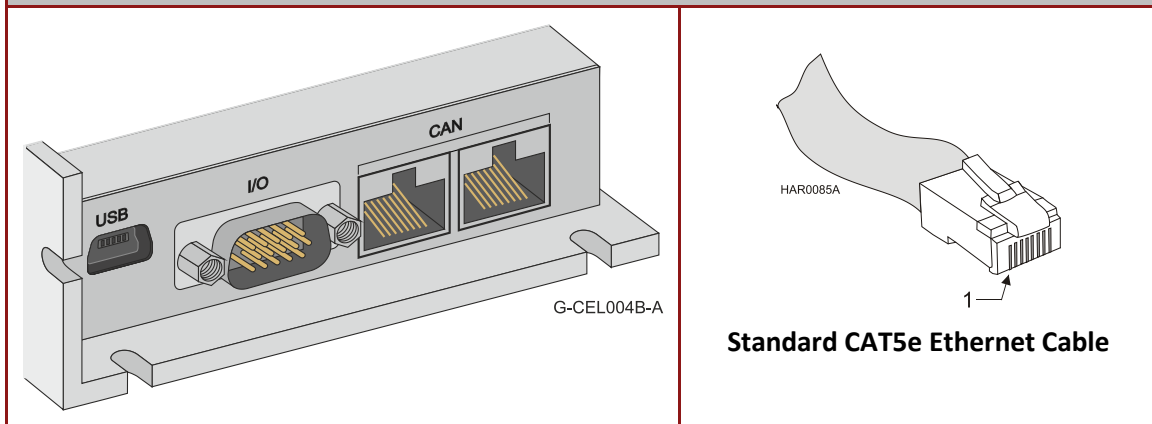
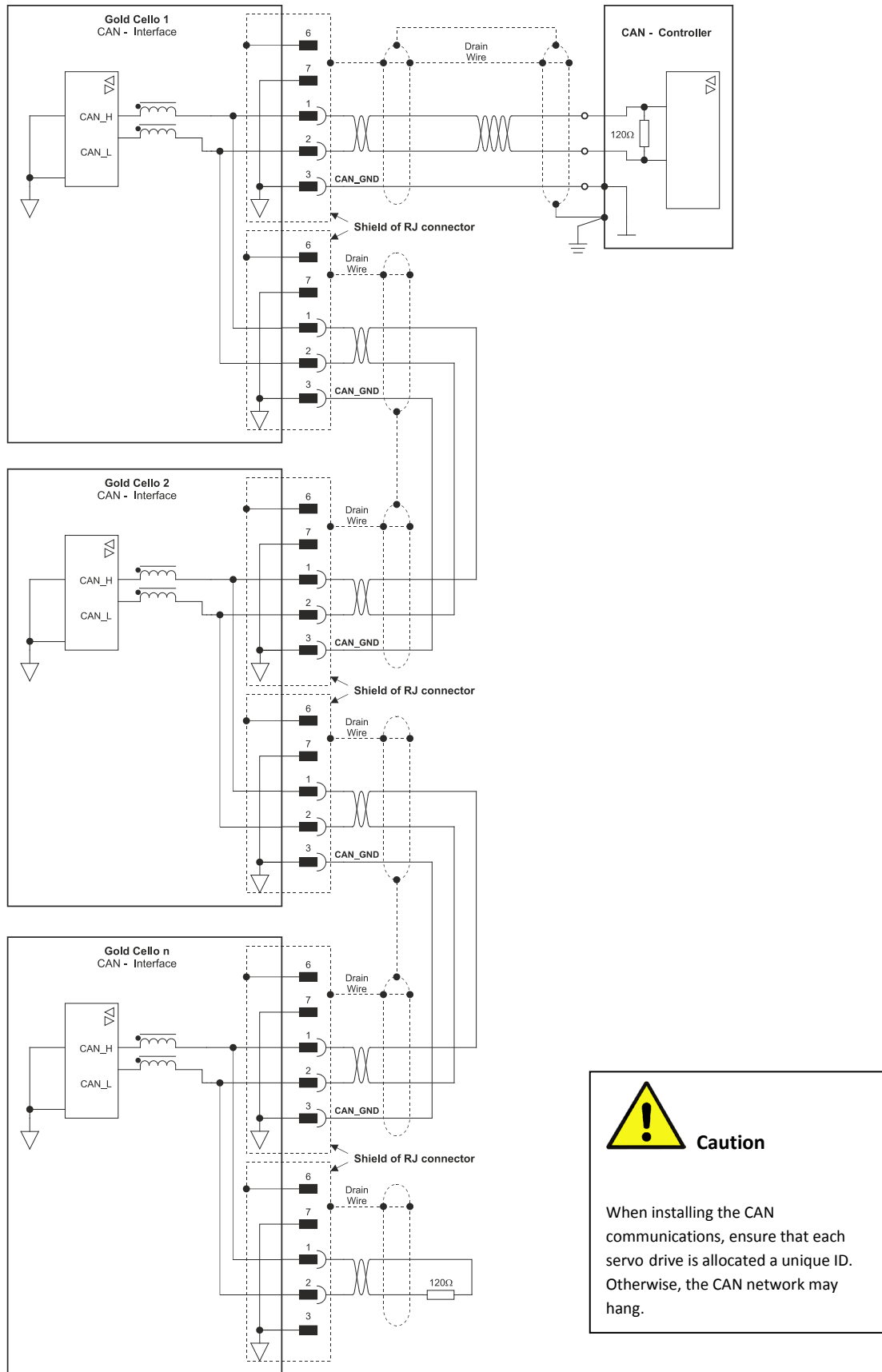



Table 14: CAN In/Out Connectors Pin Assignments



### 6.12.1. CAN Wiring

Figure 37 describes the CAN wiring diagram below.



 **Caution**

When installing the CAN communications, ensure that each servo drive is allocated a unique ID. Otherwise, the CAN network may hang.

GCEL034A

Figure 37: Gold Cello Connection Diagram – CAN



## 6.13. Powering Up

After the Gold Cello is connected to its device, it is ready to be powered up.



**Caution:**

Before applying power, ensure that the DC supply is within the specified range and that the proper plus-minus connections are in order.

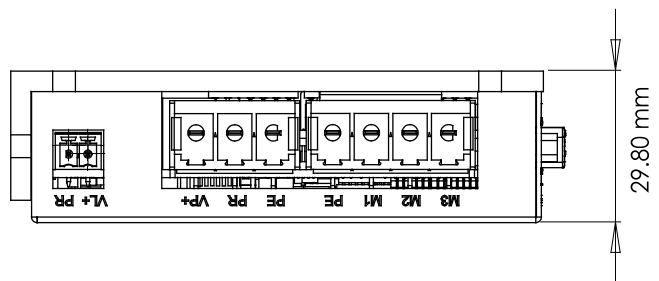
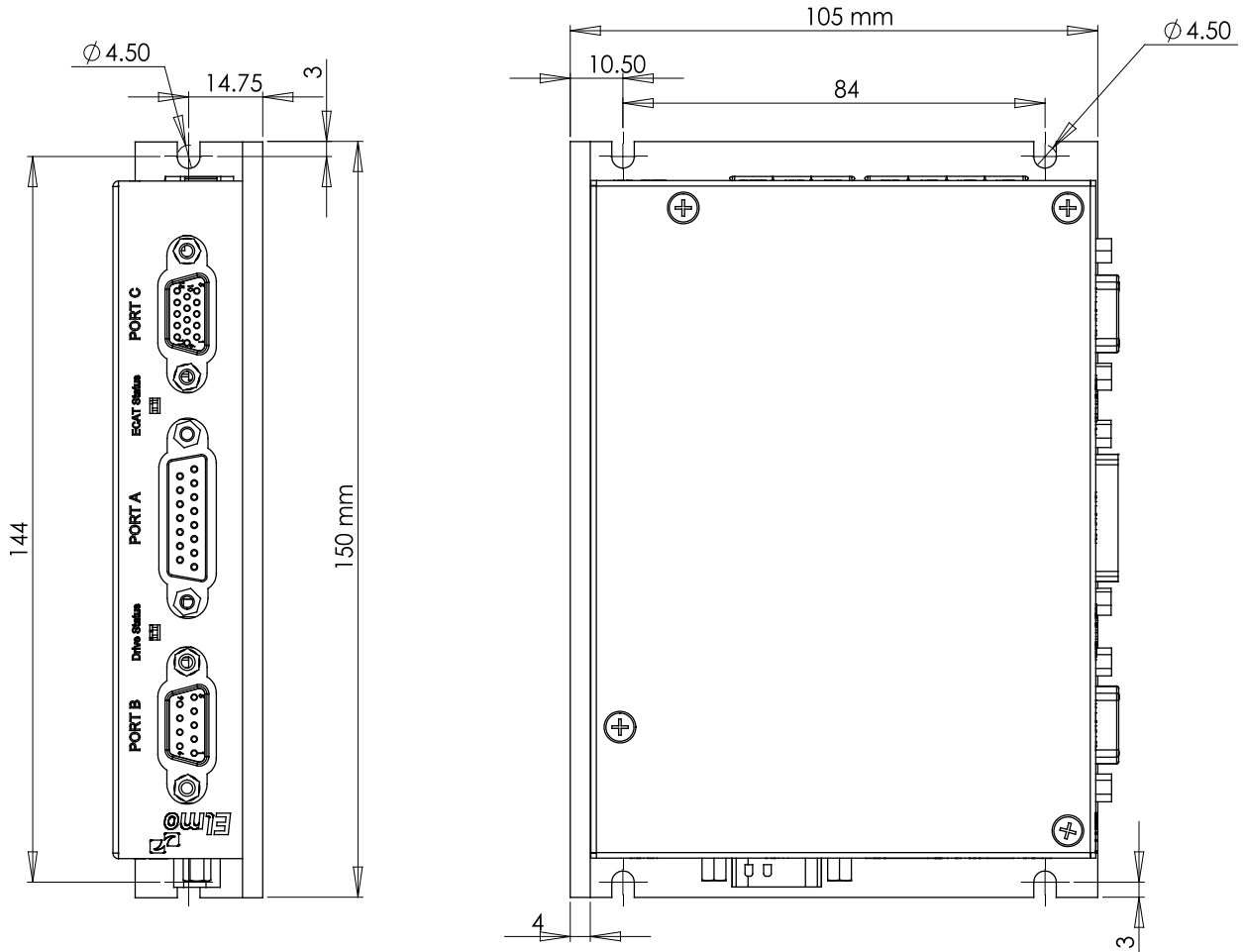
## 6.14. Initializing the System

After the Gold Cello has been connected and mounted, the system must be set up and initialized. This is accomplished using the *EASII*, Elmo's Windows-based software application. Install the application and then perform setup and initialization according to the directions in the *EASII User Manual*.



## Chapter 7: Dimensions

This chapter provides detailed technical information regarding the Gold Cello.



GCEL001A

