

Inspiring Motion

Since 1988

Gold Solo Hornet Digital Servo Drive Installation Guide EtherCAT and CAN

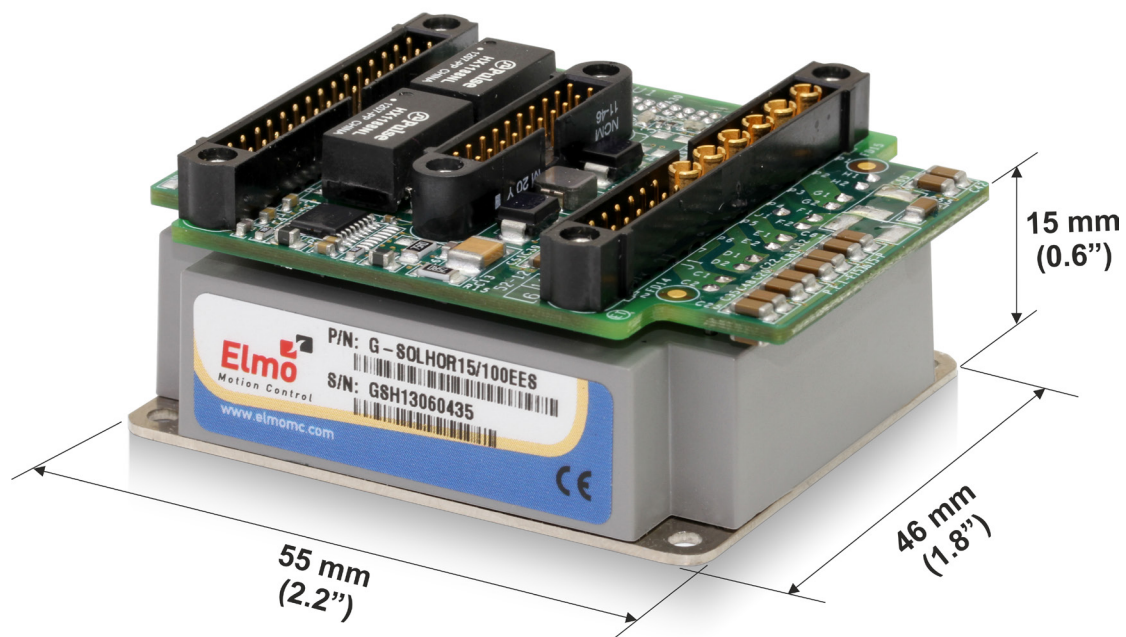

June 2018 (Ver. 1.110)

www.elmomc.com

Elmo
Motion Control

Notice

This guide is delivered subject to the following conditions and restrictions:

- This guide contains proprietary information belonging to Elmo Motion Control Ltd. Such information is supplied solely for the purpose of assisting users of the Gold Solo Hornet servo drive in its installation.
- The text and graphics included in this manual are for the purpose of illustration and reference only. The specifications on which they are based are subject to change without notice.
- Information in this document is subject to change without notice.

Document no. MAN-G-SOLHORIG-EC (Ver. 1.110)

Copyright © 2018

Elmo Motion Control Ltd.

All rights reserved.

Catalog Number

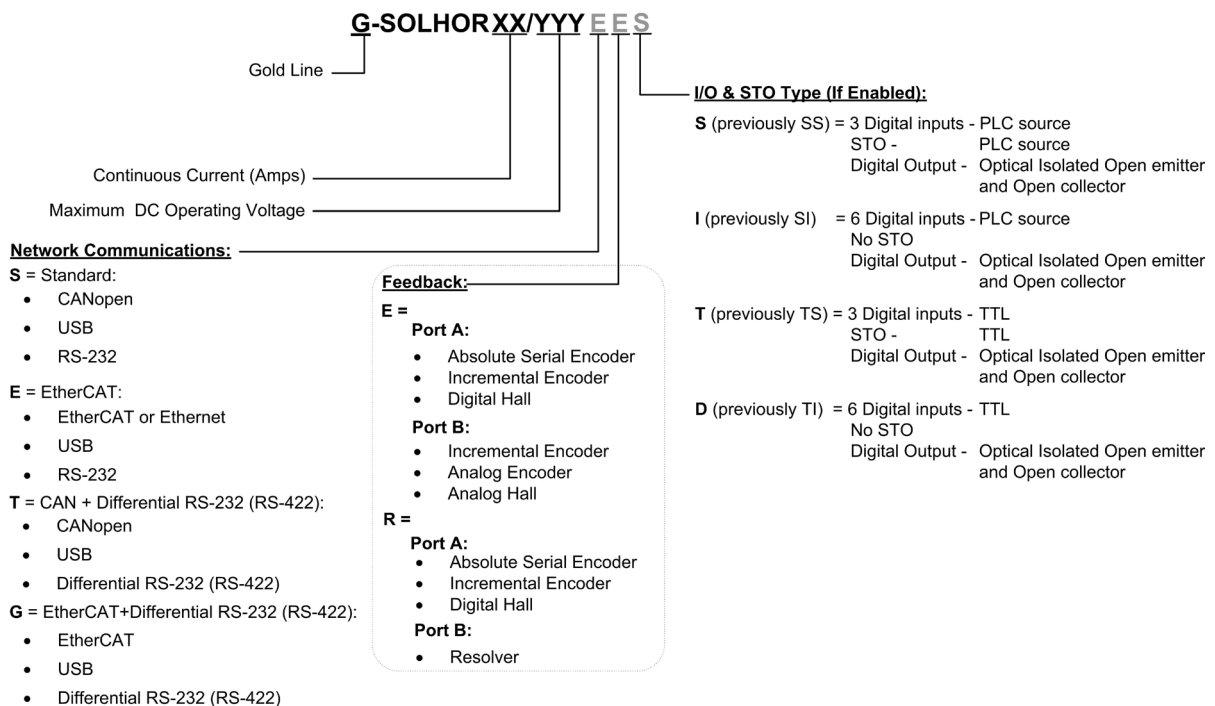

Notes

- The part number of the Gold Solo Hornet (EtherCAT version) has an E, for example, G-SOLHOR1/100E whereas the CAN version has an S, for example G-SOLHOR1/100S.

Cable Kit

- Catalog number: CBL-GSOLHORKIT01 (can be ordered separately)
- For further details, see the documentation for this cable kit (MAN-G-SOLOHOR-CBLKIT).

Revision History

Version	Date
Ver. 1.100	Aug 2013
Ver. 1.101	Oct 2013
Ver. 1.102	Aug 2014
Ver. 1.103	Sep 2014
Ver. 1.104	Nov 2014
Ver. 1.105	Mar 2015
Ver. 1.106	Mar 2015
Ver. 1.107	Apr 2015
Ver. 1.108	Oct 2017
Ver. 1.109	May 2018
Ver. 1.110	Jun 2018



- Chapter 1: This Installation Guide6**
- Chapter 2: Safety Information6**
 - 2.1. Warnings7
 - 2.2. Cautions.....7
 - 2.3. CE Marking Conformance.....7
 - 2.4. Warranty Information7
- Chapter 3: Product Description.....8**
 - 3.1.1. Accessories8
- Chapter 4: Technical Information.....9**
 - 4.1. Physical Specifications.....9
 - 4.2. Technical Data9
 - 4.2.1. Auxiliary Supply10
 - 4.2.2. Product Features11
 - 4.2.3. Environmental Conditions12
 - 4.2.4. Gold Line Standards.....13
- Chapter 5: Installation.....14**
 - 5.1. Unpacking the Drive Components14
 - 5.2. Connectors and Indicators15
 - 5.2.1. Connector Types.....15
 - 5.3. Mounting the Gold Solo Hornet16
 - 5.4. The Gold Solo Hornet Connection Diagrams.....17
- Chapter 6: Wiring.....19**
 - 6.1. Basic Recommendations20
 - 6.1.1. General20
 - 6.2. Drive Status Indicator21
 - 6.3. Connector J1 Pinouts.....22
 - 6.3.1. Power and Motor24
 - 6.3.1.1. Main, Auxiliary Power.....25
 - 6.3.2. Hall (Port A)30
 - 6.3.3. Incremental, Interpolated, Encoder and Port B31
 - 6.3.3.1. Incremental Encoder31
 - 6.3.3.2. Interpolated Analog Encoder32
 - 6.3.3.3. Resolver33
 - 6.4. Connector J2 Pinouts.....34
 - 6.4.1. Port A - Incremental Encoder36
 - 6.4.2. Port A - Absolute Serial Type Encoder.....37
 - 6.4.3. Port C - Emulated Encoder Output.....38
 - 6.4.4. Analog Input38
 - 6.4.5. Digital Input39
 - 6.4.5.1. Digital Input TTL Mode39



- 6.4.5.2. Digital Input PLC Source Mode41
- 6.4.6. Digital Output43
- 6.4.7. STO.....45
 - 6.4.7.1. STO Source Mode PLC Voltage Level.....45
 - 6.4.7.2. STO TTL Mode.....45
- 6.5. Communication Connector J3 Pinouts46
 - 6.5.1. RS-232 (J3)48
 - 6.5.2. Differential RS-232 (RS-422) (J3)49
 - 6.5.3. USB 2.0 (J3).....50
 - 6.5.4. EtherCAT Communications Version (J3).....51
 - 6.5.4.1. EtherCAT Status Indicator.....51
 - 6.5.4.2. EtherCAT Link Indicators.....52
 - 6.5.5. Ethernet Communication (J3).....52
 - 6.5.6. CAN Communications Wiring (J3).....53
- 6.6. Heat Dissipation54
 - 6.6.1. Thermal Data54
 - 6.6.2. Heat Dissipation Data54
 - 6.6.3. How to Use the Charts.....55
- Chapter 7: Powering Up56**
 - 7.1. Initializing the System56
- Chapter 8: Dimension.....57**



Chapter 1: This Installation Guide

This installation Guide details the technical data, pinouts, and power connectivity of the Gold Solo Hornet. For a comprehensive detailed description of the functions refer to the MAN-G-Panel Mounted Drives Hardware manual which describes Panel Mounted products.

Chapter 2: Safety Information

In order to achieve the optimum, safe operation of the Gold Solo Hornet, it is imperative that you implement the safety procedures included in this installation guide. This information is provided to protect you and to keep your work area safe when operating the Gold Solo Hornet and accompanying equipment.

Please read this chapter carefully before you begin the installation process.

Before you start, ensure that all system components are connected to earth ground. Electrical safety is provided through a low-resistance earth connection.

Only qualified personnel may install, adjust, maintain and repair the servo drive. A qualified person has the knowledge and authorization to perform tasks such as transporting, assembling, installing, commissioning and operating motors.

The Gold Solo Hornet contains electrostatic-sensitive components that can be damaged if handled incorrectly. To prevent any electrostatic damage, avoid contact with highly insulating materials, such as plastic film and synthetic fabrics. Place the product on a conductive surface and ground yourself in order to discharge any possible static electricity build-up.

To avoid any potential hazards that may cause severe personal injury or damage to the product during operation, keep all covers and cabinet doors shut.

The following safety symbols are used in this and all Elmo Motion Control manuals:



Warning:

This information is needed to avoid a safety hazard, which might cause bodily injury or death as a result of incorrect operation.



Caution:

This information is necessary to prevent bodily injury, damage to the product or to other equipment.



Important:

Identifies information that is critical for successful application and understanding of the product.



2.1. Warnings

- To avoid electric arcing and hazards to personnel and electrical contacts, never connect/disconnect the servo drive while the power source is on.
- Power cables can carry a high voltage, even when the motor is not in motion. Disconnect the Gold Solo Hornet from all voltage sources before servicing.
- The high voltage products within the Gold Line range contain grounding conduits for electric current protection. Any disruption to these conduits may cause the instrument to become hot (live) and dangerous.
- After shutting off the power and removing the power source from your equipment, wait at least 1 minute before touching or disconnecting parts of the equipment that are normally loaded with electrical charges (such as capacitors or contacts). Measuring the electrical contact points with a meter, before touching the equipment, is recommended.



2.2. Cautions

- The maximum DC power supply connected to the instrument must comply with the parameters outlined in this guide.
- When connecting the Gold Solo Hornet to an approved isolated auxiliary power supply, connect it through a line that is separated from hazardous live voltages using reinforced or double insulation in accordance with approved safety standards.
- Before switching on the Gold Solo Hornet, verify that all safety precautions have been observed and that the installation procedures in this manual have been followed.
- Make sure that the Safe Torque Off is operational

2.3. CE Marking Conformance

The Gold Solo Hornet is intended for incorporation in a machine or end product. The actual end product must comply with all safety aspects of the relevant requirements of the European Safety of Machinery Directive 2006/42/EC as amended, and with those of the most recent versions of standards EN 60204-1 and EN ISO 12100 at the least, and in accordance with 2006/95/EC.

Concerning electrical equipment designed for use within certain voltage limits, the Gold Solo Hornet meets the provisions outlined in 2006/95/EC. The party responsible for ensuring that the equipment meets the limits required by EMC regulations is the manufacturer of the end product.

2.4. Warranty Information

The products covered in this manual are warranted to be free of defects in material and workmanship and conform to the specifications stated either within this document or in the product catalog description. All Elmo drives are warranted for a period of 12 months from the date of shipment. No other warranties, expressed or implied — and including a warranty of merchantability and fitness for a particular purpose — extend beyond this warranty.



Chapter 3: Product Description

The Gold Solo Hornet is an integrated solution delivering up to **1.6 kW of continuous power** or **3.2 kW of peak power** in a compact package (59.70 x 46.50 x 25.00 mm or 2.35" x 1.83" x 0.98") and designed to simply and efficiently connect Elmo's Gold Hornet servo drive directly to the application. The solution consists of the Gold Hornet together with a convenient connection interface which either eliminates or reduces development time and resources when designing an application's PCB board.

This advanced, high power density servo drive provides top performance, advanced networking and built-in safety, as well as a fully featured motion controller and local intelligence. The Gold Solo Hornet is powered by a single 12 V – 195 V isolated DC power source (not included) and a "smart" control-supply algorithm enables the drive to operate up to 95V with only one power supply with no need for an auxiliary power supply for the logic.

The drive can operate as a stand-alone device or as part of a multi-axis system in a distributed configuration on a real-time network.

The Gold Solo Hornet drive is easily set up and tuned using Elmo Application Studio (EASII) software tools. As part of the Gold product line, it is fully programmable with the Elmo motion control language. For more about software tools refer to the Elmo Application Studio Software Manual.

The Gold Solo Hornet is available in a variety of options. There are multiple power rating options, two different communications options – Standard (S suffix in the part number) or EtherCAT (E suffix in the part number), a variety of feedback selections and I/O configuration possibilities.

3.1.1. Accessories

Cable Kit, catalog number: CBL-GSOLHORKIT01 (can be ordered separately)

For further details, see the documentation for this cable kit (MAN-G-SOLOHOR-CBLKIT).



Chapter 4: Technical Information

4.1. Physical Specifications

Feature	Units	All Types
Weight	g (oz)	106 g (3.74 oz)
Dimensions	mm (in)	59.70 x 46.50 x 25.00 mm (2.35" x 1.83" x 0.98")
Mounting method		Panel Mounted

4.2. Technical Data

Feature	Units	2.5/100	5/100	10/100	15/100	20/100
Minimum supply voltage	VDC	12				
Nominal supply voltage	VDC	85				
Maximum supply voltage	VDC	95				
Maximum continuous power output	W	200	400	800	1200	1600
Efficiency at rated power (at nominal conditions)	%	> 99				
Maximum output voltage		> 95% of DC bus voltage at f = 22 kHz				
Auxiliary power supply	VDC	12 to 95 VDC (up to 6 VA inc. 5 V/2 x 200 mA for encoder)				
Amplitude sinusoidal/DC continuous current	A	2.5	5	10	15	20
Sinusoidal continuous RMS current limit (I _c)	A	1.8	3.5	7	10.6	14.1
Peak current limit	A	2 x I _c				

Table 1: Power Rating

Note on current ratings: The current ratings of the Gold Solo Hornet are given in units of DC amperes (ratings that are used for trapezoidal commutation or DC motors). The RMS (sinusoidal commutation) value is the DC value divided by 1.41.



Elmo now offers a 200 VDC maximum output rating selection of Gold Solo Hornet, according to the following technical data:

Feature	Units	3/200	6/200	9/200
Minimum supply voltage	VDC	12		
Nominal supply voltage	VDC	170		
Maximum supply voltage	VDC	195		
Maximum continuous power output	W	480	960	1450
Efficiency at rated power (at nominal conditions)	%	> 99		
Maximum output voltage		> 95% of DC bus voltage at f = 22 kHz		
Auxiliary power supply	VDC	12 to 95 VDC (up to 6 VA inc. 5 V/2 x 200 mA for encoder)		
Amplitude sinusoidal/DC continuous current	A	3	6	9
Sinusoidal continuous RMS current limit (Ic)	A	2.1	4.2	6.3
Peak current limit	A	2 x Ic		

4.2.1. Auxiliary Supply

Feature	Details
Auxiliary power supply	<i>Isolated DC source only</i>
Auxiliary supply input voltage	12 to 95 V
Auxiliary supply input power	≤ 4 VA without external loading ≤ 6 VA with full external loading



4.2.2. Product Features

Main Feature	Details	Presence and No.
STO	Without STO <i>or</i>	✓
	TTL <i>or</i>	✓
	PLC Source	✓
Digital Input	TTL <i>or</i>	6 without STO or 3 with STO
	PLC Source	6 without STO or 3 with STO
Digital Output	Optical Isolated Open Emitter and Open Collector	2
Analog Input	Differential ±10V	1
Feedback	Standard Port A, B, & C	✓
Communication	USB	✓
	EtherCAT	✓
	CAN	✓
	RS-232	✓
	Differential RS-232 (RS-422)	✓



4.2.3. Environmental Conditions

You can guarantee the safe operation of the Gold Solo Hornet by ensuring that it is installed in an appropriate environment.



Caution:

The Gold Solo Hornet dissipates its heat by convection. The maximum ambient operating temperature of 70 °C (160 °F) must not be exceeded.

The ExtriQ series of drives support the following extended environmental conditions.

Feature	Operation Conditions	Range
Ambient Temperature Range	Non-operating conditions	-50 °C to +100 °C (-58 °F to 212 °F)
	Operating conditions	-40 °C to +70 °C (-40 °F to 160 °F)
Temperature Shock	Non-operating conditions	-40 °C to +70 °C (-40 °F to 160 °F) within 3 min
Altitude	Non-operating conditions	Unlimited
	Operating conditions	-400 m to 12,000 m (-1312 to 39370 feet)
Maximum Humidity	Non-operating conditions	Up to 95% relative humidity non-condensing at 35 °C (95 °F)
	Operating conditions	Up to 95% relative humidity non-condensing at 25 °C (77 °F), up to 90% relative humidity non-condensing at 42 °C (108 °F)
Vibration	Operating conditions	20 Hz to 2,000 Hz, 14.6 GRMS
Mechanical Shock	Non-operating conditions	±40g; Half sine, 11 msec
	Operating conditions	±20g; Half sine, 11 msec
Protection level		IP00



4.2.4. Gold Line Standards

The following table describes the Main Standards of the Gold Solo Hornet servo drive. For further details refer to the MAN-G-Board Level Modules Hardware Manual.

Main Standards	Item
The related standards below apply to the performance of the servo drives as stated in the environmental conditions in section 4.2.3 Environmental Conditions above.	
STO IEC 61800-5-2:2007 SIL 3	Adjustable speed electrical power drive systems – Safety requirements – Functional
EN ISO 13849-1:2008 PL e, Cat 3	Safety of machinery – Safety-related parts of control systems.
Approved IEC/EN 61800-5-1	Adjustable speed electrical power drive systems Safety requirements – Electrical, thermal and energy
Recognized UL61800-5-1	Adjustable speed electrical power drive systems Safety requirements – Electrical, thermal and energy
Recognized UL 508C	Power Conversion Equipment
In compliance with UL 840	Insulation Coordination Including Clearances and Creepage Distances for Electrical Equipment
Conformity with CE 2006/95/EC	Low-voltage directive 2006/95/EC
Recognized CSA C22.2 NO. 14-13	Industrial Control Equipment



Chapter 5: Installation

The Gold Solo Hornet must be installed in a suitable environment and properly connected to its voltage supplies and the motor.

5.1. Unpacking the Drive Components

Before you begin working with the Gold Solo Hornet, verify that you have all of its components, as follows:

- The Gold Solo Hornet servo drive
- The Elmo Application Studio software and software manual

The Gold Solo Hornet is shipped in a cardboard box with Styrofoam protection.

To unpack the Gold Solo Hornet:

1. Carefully remove the servo drive from the box and the Styrofoam.
2. Check the drive to ensure that there is no visible damage to the instrument. If any damage has occurred, report it immediately to the carrier that delivered your drive.
3. To ensure that the Gold Solo Hornet you have unpacked is the appropriate type for your requirements, locate the part number sticker on the side of the Gold Solo Hornet. It looks like this:

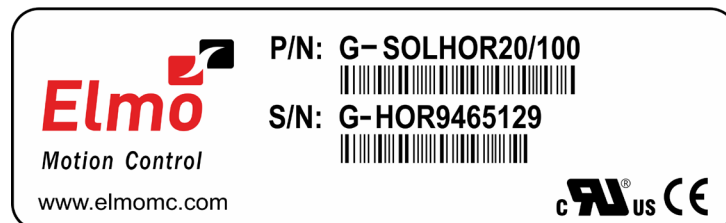

4. Verify that the Gold Solo Hornet type is the one that you ordered, and ensure that the voltage meets your specific requirements.

The part number at the top provides the type designation. Refer to the appropriate part number in the section Catalog Number at the beginning of the installation guide.



5.2. Connectors and Indicators

The Gold Solo Hornet has 3 connectors (connector's version).

5.2.1. Connector Types

Port	No. Pins	Type	Function
J1	6	Nicomatic CMM 220 6 HP/12 P	Motor, Power
	12		Port B, Hall Sensors
J2	30	Nicomatic CMM 220 2 x 15P	I/O, Auxiliary Supply, Feedback
J3	20	Nicomatic CMM 220 2 x 10P	Communication

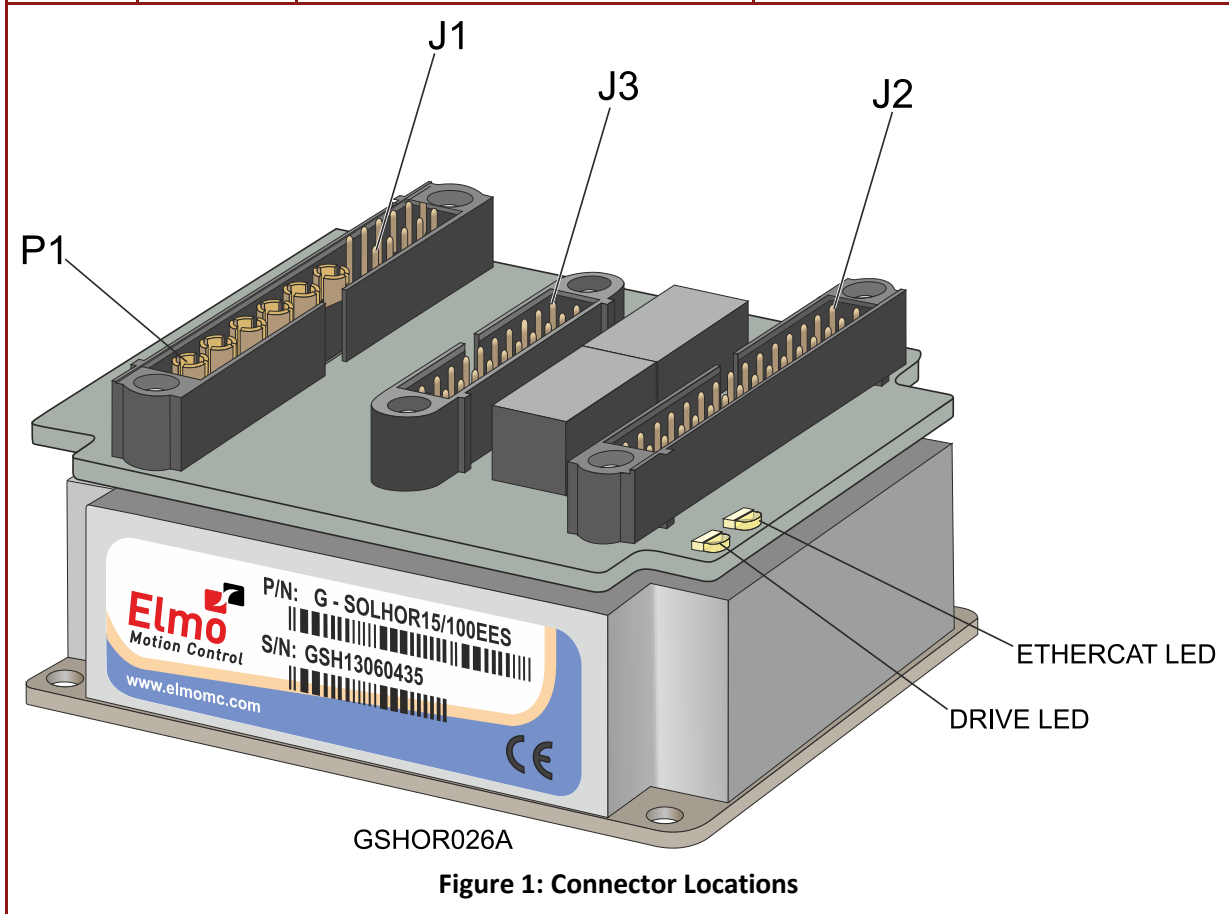

Table 2: Connector Types



5.3. Mounting the Gold Solo Hornet

The Gold Solo Hornet was designed for mounting on a surface. When integrating the Gold Solo Hornet into a device, be sure to leave about 1 cm (0.4") outward from the heat-sink to enable free air convection around the drive. If the Gold Solo Hornet is enclosed in a metal chassis, we recommend that the Gold Solo Hornet be screw-mounted to it to help with heat dissipation. The Gold Solo Hornet has screw-mount holes on each corner of the heat-sink for this purpose – see below.

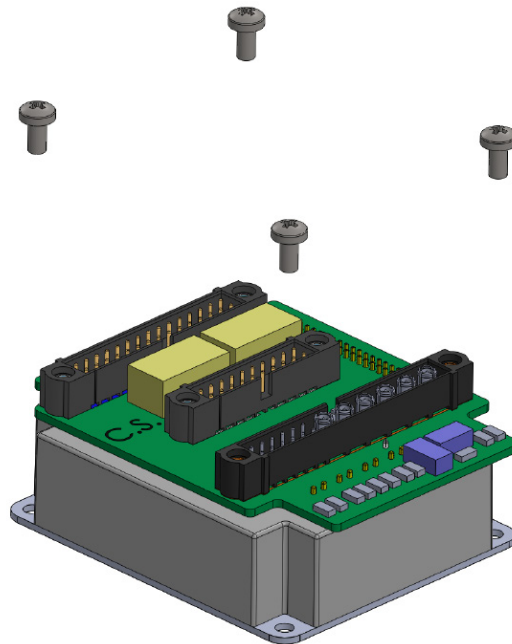

Figure 2: Mounting the Gold Solo Hornet

When the Gold Solo Hornet is not connected to a metal chassis, the application's thermal profile may require a solution for heat dissipation due to insufficient air convection. In this case, we recommend that you connect an external heat-sink. Elmo has an external heat-sink (Catalog number: WHI-HEATSINK-2) that can be ordered for this purpose – see below.

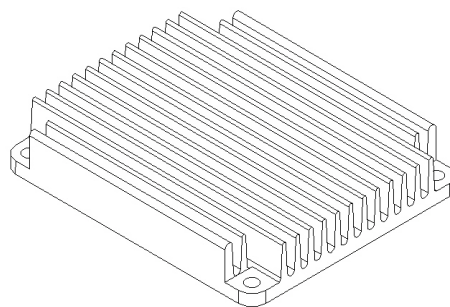
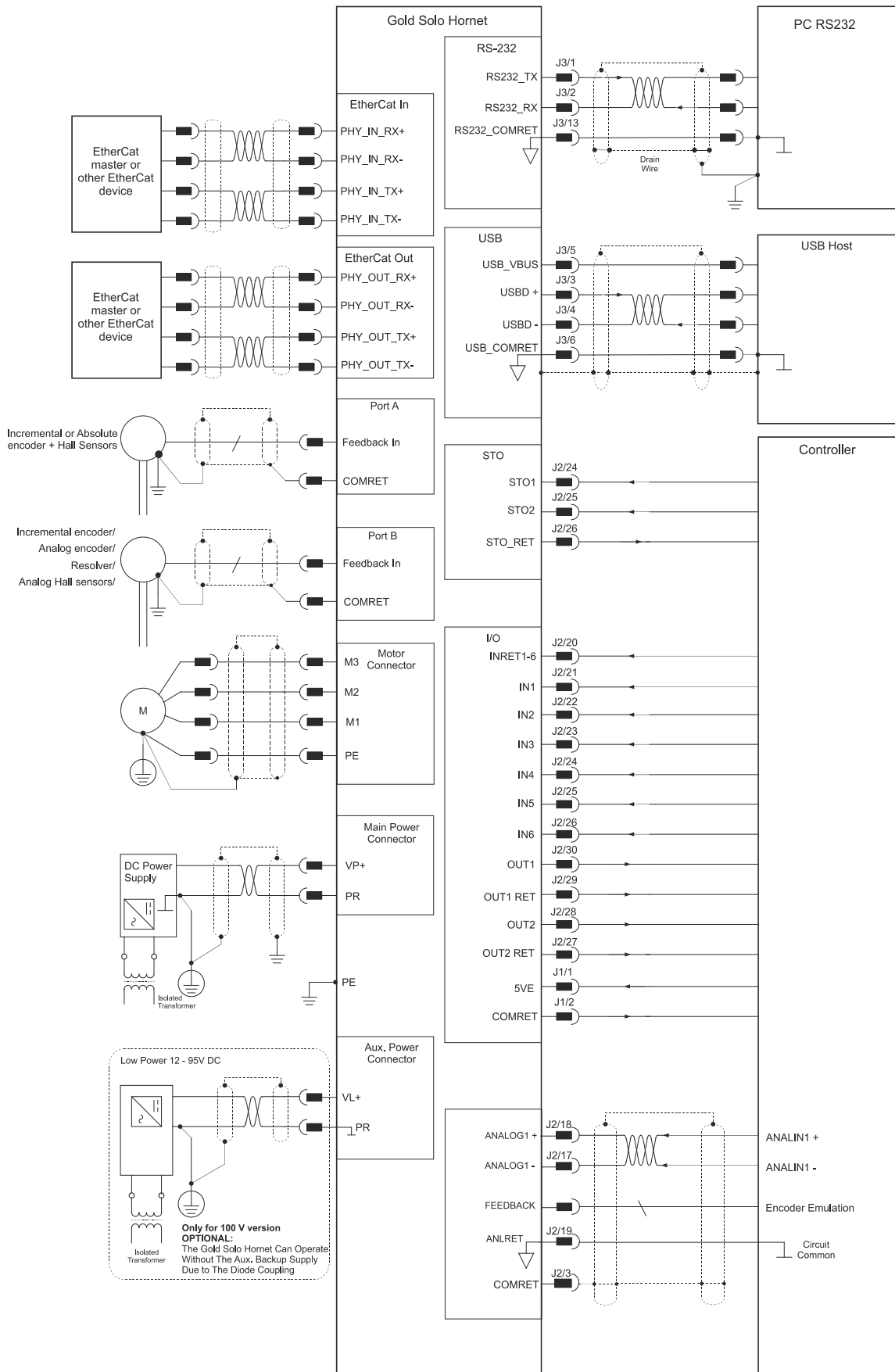

Figure 3: Gold Solo Hornet External Heat-sink



5.4. The Gold Solo Hornet Connection Diagrams



GSHOR001B

Figure 4: The Gold Solo Hornet Connection Diagram - EtherCAT

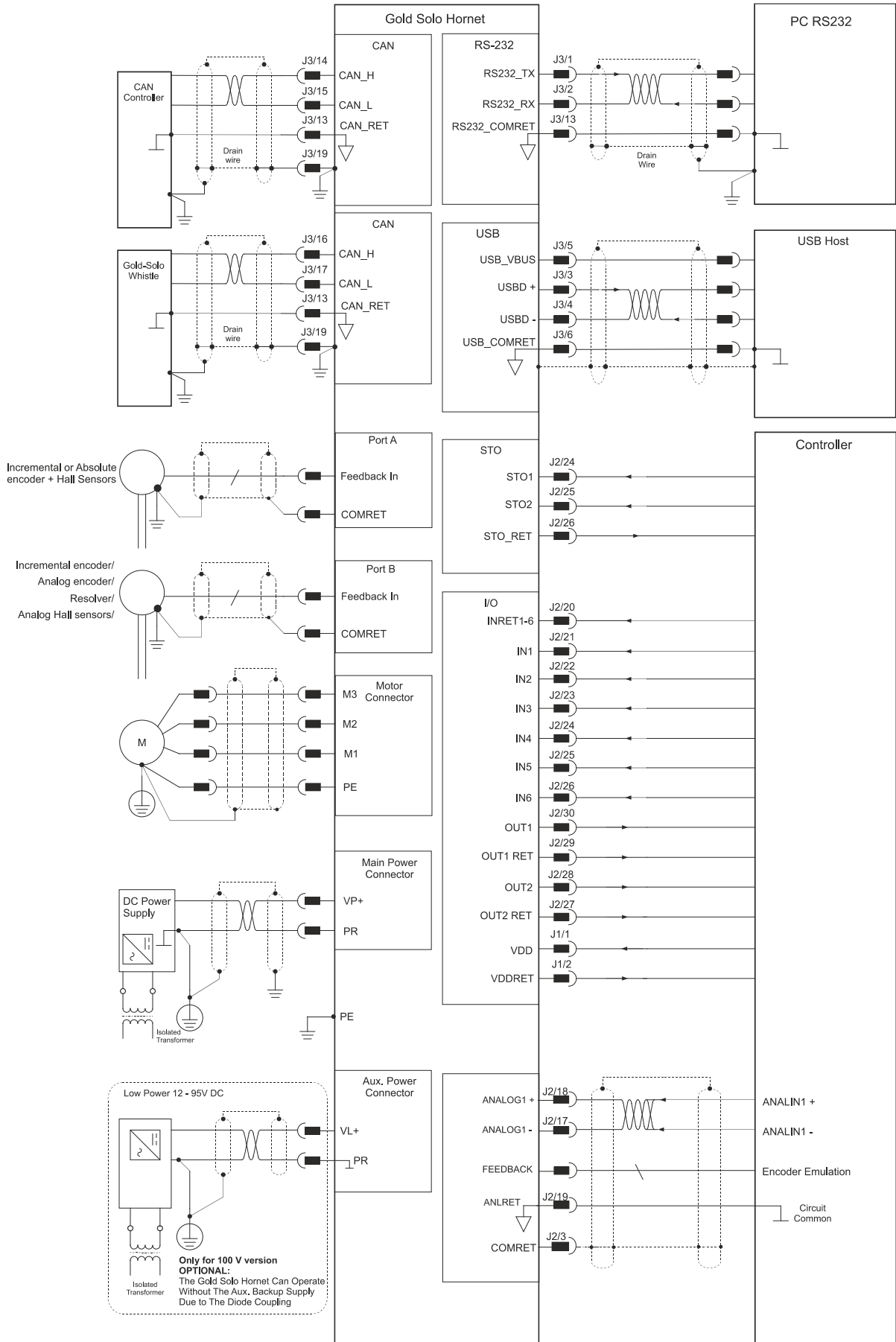

GSHOR002B



Figure 5: The Gold Solo Hornet Connection Diagram – CAN



Chapter 6: Wiring

Once the product is mounted, you are ready to wire the device. Proper wiring, grounding and shielding are essential for ensuring safe, immune and optimal servo performance of the drive.

The following table legend describes the wiring symbols detailed in all installation guides.

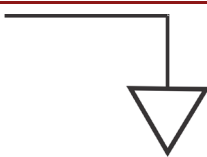
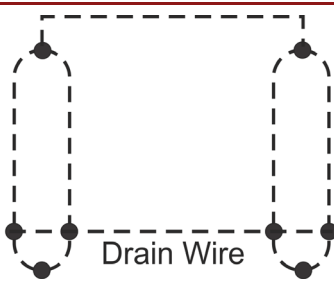
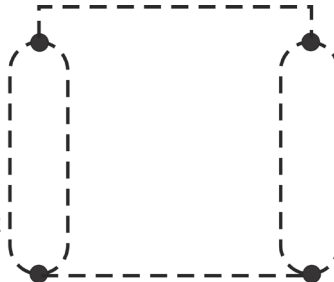
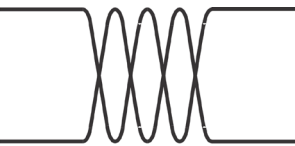
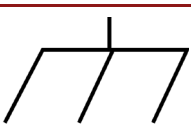
Wiring Symbol	Description
 GGEN_101D-A	Earth connection (PE)
 GGEN_101D-B	Earth Connection
 GGEN_101D-C	Common at the Controller
 GGEN_101D-D	Shielded cable with drain wire. The drain wire is a non-insulated wire that is in direct contact with the braid (shielding). Shielded cable with drain wire significantly simplifies the wiring and earthing.
 GGEN_101D-E	Shielded cable braid only, without drain wire.
 GGEN_101D-F	Twisted-pair wires
 GGEN_101D-K	Analog Ground

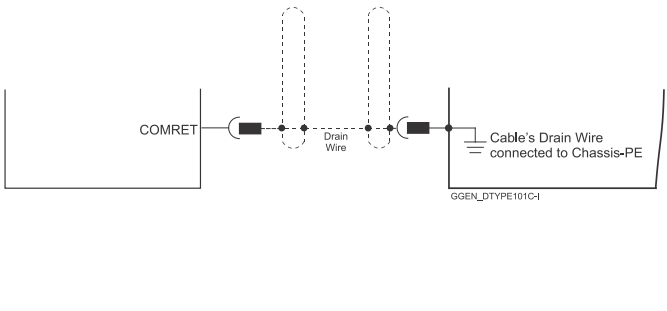

Wiring Symbol	Description
	<p>Encoder Earthing.</p> <p>The cable's shield is connected to the chassis (PE) in the connector.</p> <p>Earthing the Encoder and connecting the Earth (PE) to the drive COMRET is mandatory to insure reliable operation, high noise immunity and rejection of voltage common mode interferences.</p>

6.1. Basic Recommendations

6.1.1. General

1. Use shielded cables. For best results, the cable should have an aluminum foil shield covered by copper braid, and should contain a drain wire.
Use 24, 26 or 28 AWG twisted-pair shielded with drain wire cables.
2. Keep the cable as short as possible.
Do not mount the power cables of the motor and power bus in the proximity of the control and feedback cables.
3. Ensure that in normal operating conditions, the "earth connection" wires and shield of the control cables *carry no current*. The only time these conductors carry current is under abnormal conditions, when electrical equipment has become a potential shock or fire hazard while conducting external EMI interferences directly to ground, in order to prevent them from affecting the drive. Failing to meet this requirement might result in drive/controller/host failure.
4. After completing the wiring, carefully inspect all wires to ensure tightness, good solder of joints and general safety.
5. Where there is only one COMRET pin (Common Return) in the connector, which MUST be connected to the DRAIN WIRE and also to COMRET signal of the cable, it is necessary to connect the drain wire and COMRET signal to the same pin.



6.2. Drive Status Indicator

Figure 6 shows the position of the red/green dual LED, which is used for immediate indication of the Initiation and Working states. For details refer to Chapter 7 Drive Status Indicator, in the MAN-G-Panel Mounted Drives Hardware manual.

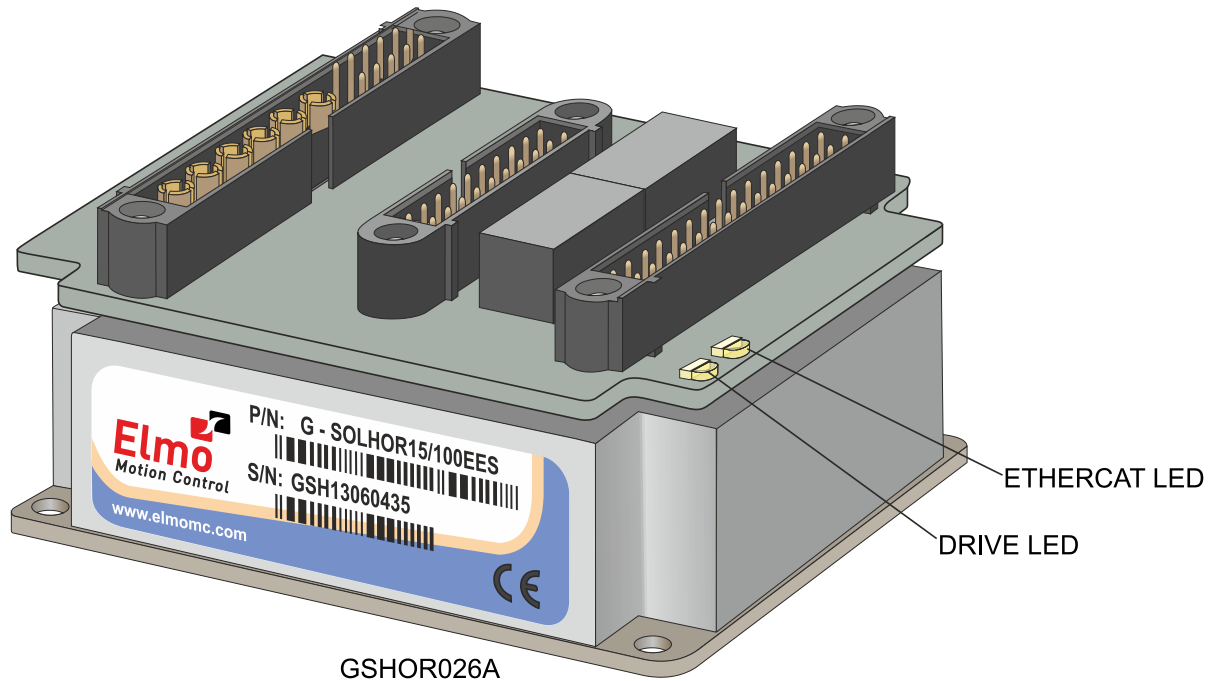

Figure 6: Drive Status LED

The red/green dual LED is used for immediate indication of the following states:

- **Initiation state:** In this state the LED indicates whether the drive is in the boot state (blinking red) or in the operational state (steady red).
- **Working state:** In this state the LED indicates whether the drive is in an amplifier failure state (red) or is ready to enable the motor (green).



6.3. Connector J1 Pinouts

J1 consists of a Power, Motor (6 pins) and Port B, Hall sensors (12 pins) connector.

Pin	Signal	Function	Cable	
P1	VP+	Positive Power Input	Power	
P2	PR	Power Return	Power	
P3	PE	Protective Earth	Power	
			AC Motor	DC Motor
P4	M1	Motor Phase	Motor	N/C
P5	M2	Motor Phase	Motor	Motor
P6	M3	Motor Phase	Motor	Motor
1	+5V	Encoder +5V Supply		
2	COMRET	Common Return		
12	COMRET	Common Return		

Hall Encoder Port A		
Pin	Signal	Function
9	HA	Hall Sensor A
10	HB	Hall Sensor B
11	HC	Hall Sensor C

Incremental or Interpolated Analog Encoder Port B			Resolver Port	
Pin	Signal	Function	Signal	Function
3	PORTB_ENC_A+/SIN+	Channel A+/Sine+	SIN+	Sine+
4	PORTB_ENC_A-/SIN-	Channel A-/Sine-	SIN-	Sine-
5	PORTB_ENC_B+/COS+	Channel B+/Cosine+	COS+	Cosine+
6	PORTB_ENC_B-/COS-	Channel B-/Cosine-	COS-	Cosine-
7	PORTB_ENC_INDEX+/ANALOG_INDEX+	Channel_Index+/Analog_Index+	RESOLVER_OUT+	Vref f=1/TS, 50 mA Max.
8	PORTB_ENC_INDEX-/ANALOG_INDEX-	Channel_Index-/Analog_Index-	RESOLVER_OUT-	Vref Complement f= 1/TS, 50 mA Maximum



Pin Positions

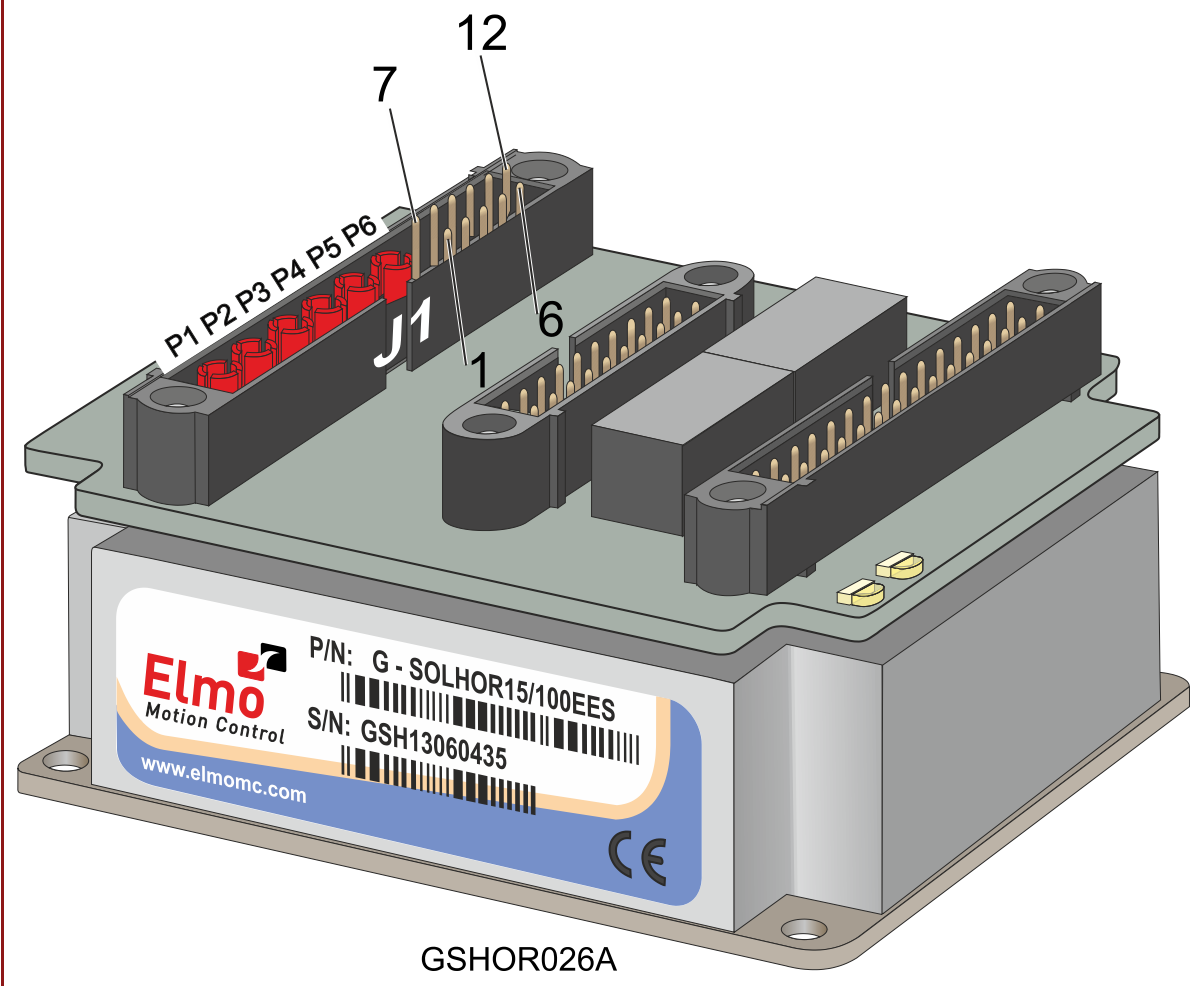

Table 3: J1 Connector



6.3.1. Power and Motor

See Chapter 8 in the in the MAN-G-Panel Mounted Drives Hardware manual for full details.

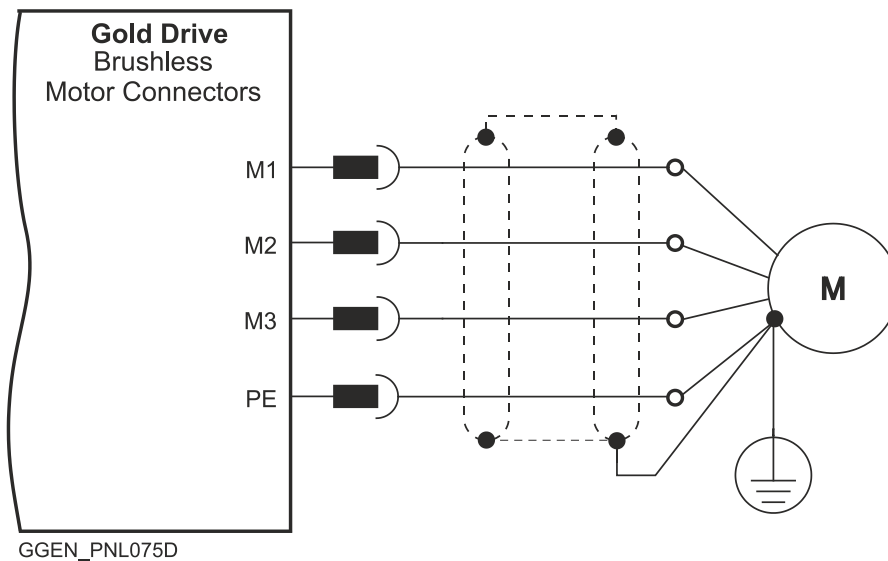

Figure 7: Brushless Motor Power Connection Diagram

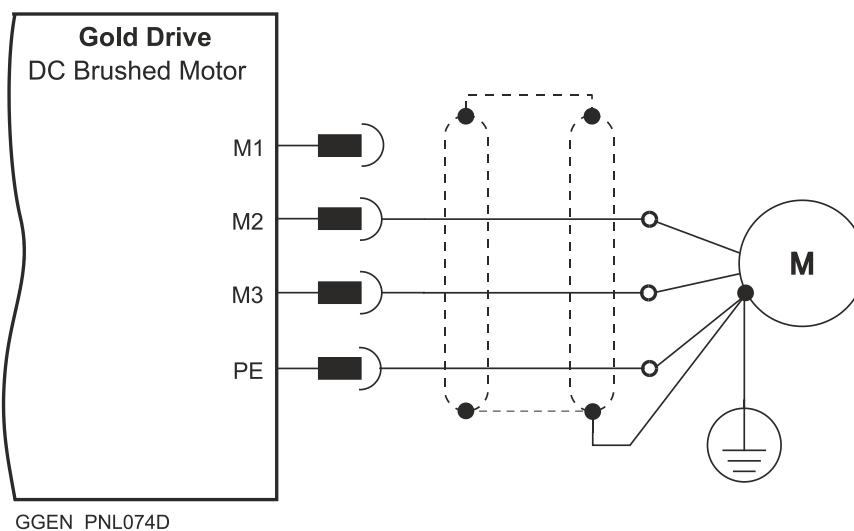

Figure 8: DC Brushed Motor Power Connection Diagram



6.3.1.1. Main, Auxiliary Power

This section describes the Main and Auxiliary Power for power ratings 200V and 100V, and provides details for the optional Backup (Auxiliary) Supply.

- The Gold Solo Hornet Power rating is 12 to 195 VDC
- There are Two power ratings for Gold Solo Hornet; 100V and 200V:
 - **For power rating 200V**
Two power isolated DC power sources are required, main power 12 - 195V and Auxiliary Power 12-95V for the logic.
 - **For power rating of 100V**
Single DC Power Supply - Power to the Gold Solo Hornet is provided by a 12–95 VDC single isolated DC power source (not included with the Gold Solo Hornet). A “smart” control-supply algorithm enables the Gold Solo Hornet to operate with only one power supply with no need for an auxiliary power supply for the logic.

Optional Backup (Auxiliary) Supply

If backup functionality is required in case of power loss, e.g., to keep the original position, a 12–95 VDC external isolated supply should be connected (via the Gold Solo Hornet’s VL+ terminal). This is more flexible than the requirement for 24 VDC supply.

If backup is not needed, a single power supply is used for both the power and logic circuits.

There are two voltage ratings of the Gold Solo Hornet, therefore the correct power supply must be used, according to the maximum operating voltage of the Gold Solo Hornet. Refer to section 4.2 Technical Data.

Power to the Gold Solo Hornet is provided by a 12 to 195 VDC source.

Connect the DC power cable to the VP+ and PR terminals on the Main Power Connector.

To connect the DC power supply

1. The source of the 12 to 195 VDC power supply must be isolated.
2. For best immunity, it is highly recommended to use twisted and shielded cables for the DC power supply. The gauge is determined by the actual current consumption of the motor.
3. Connect the cable shield to the closest ground connection near the power supply.
4. Connect the PE to the closest ground connection near the power supply.
5. Connect the PR to the closest ground connection near the power supply.
6. Before applying power, first verify the polarity of the connection.



6.3.1.1.a Power Rating 200 V

For Power Rating 200 V, two power isolated DC power sources are required, main power **12 - 195V** and auxiliary Power **12-95V** for the logic.

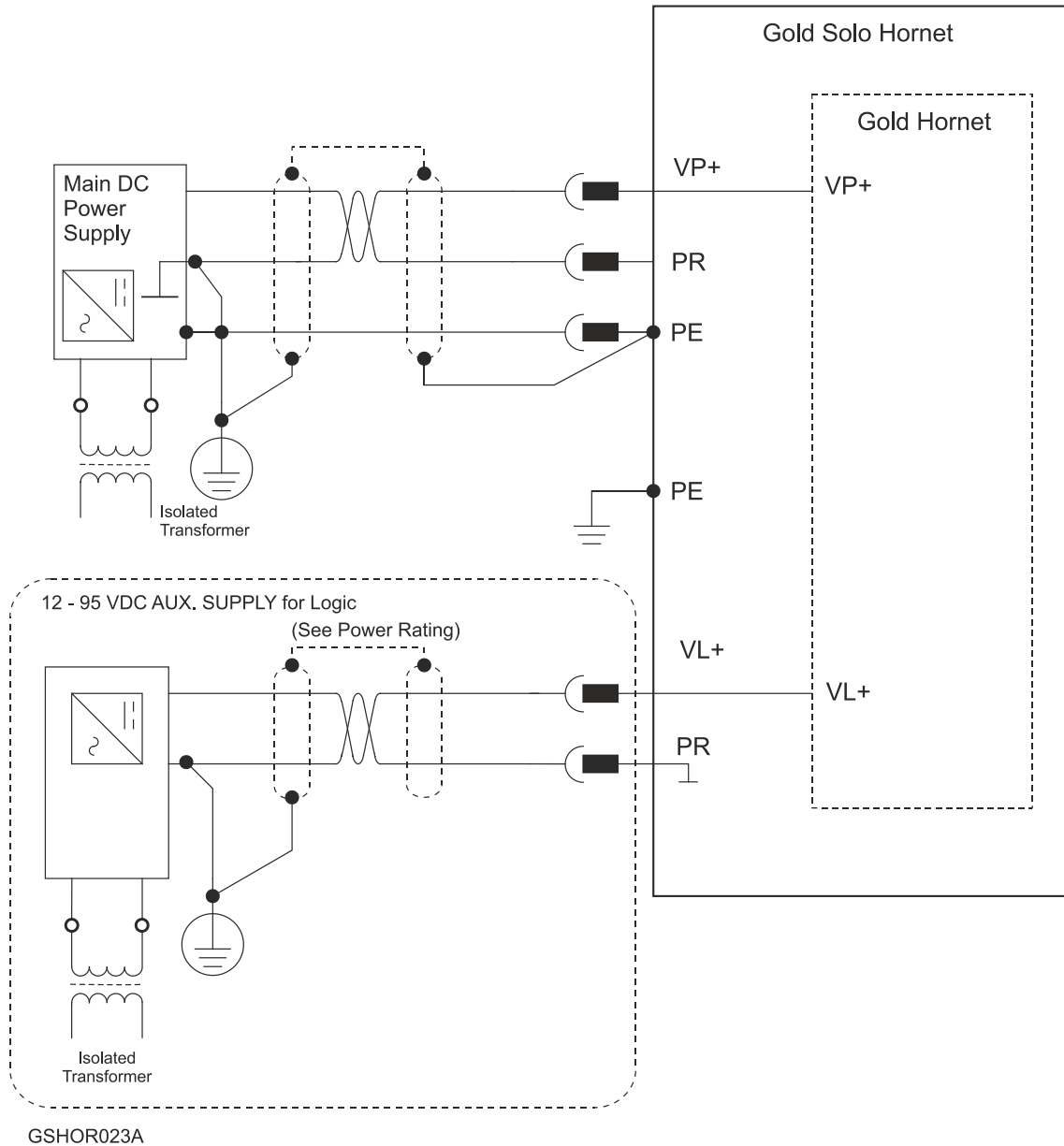

Figure 9: 200 VDC Power Source Connection Diagram



6.3.1.1.b Power Rating 100 V - Single Power Supply

For power rating 100 V, a single Power Supply is required which contains a “smart” control-supply algorithm, enabling the Gold Solo Hornet to operate with only one power supply with no need for an auxiliary power supply for the logic.

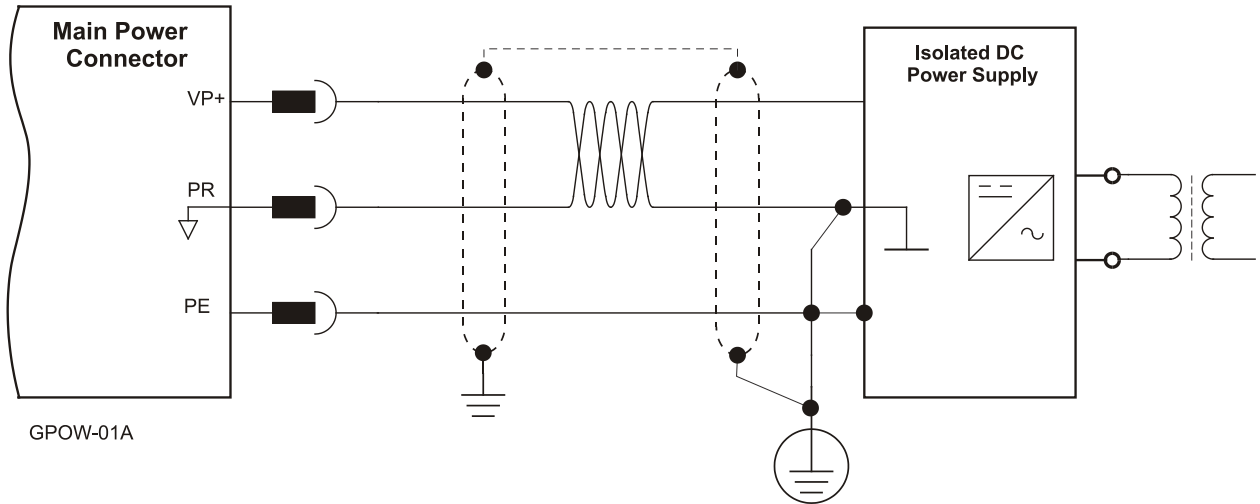

Figure 10: Main Power Supply Connection Diagram (no Auxiliary Supply)



6.3.1.1.c Auxiliary Power Supply (J2)

Note: The source of the Auxiliary Supply must be isolated.

Connect the VL+ and PR pins on the Gold Solo Hornet. The Gold Solo Hornet Auxiliary Power is part of the J2 connector.

Pin (J2)	Signal	Function
2	PR	Auxiliary Supply Return
1	VL+	Auxiliary Power Input

Pin Positions

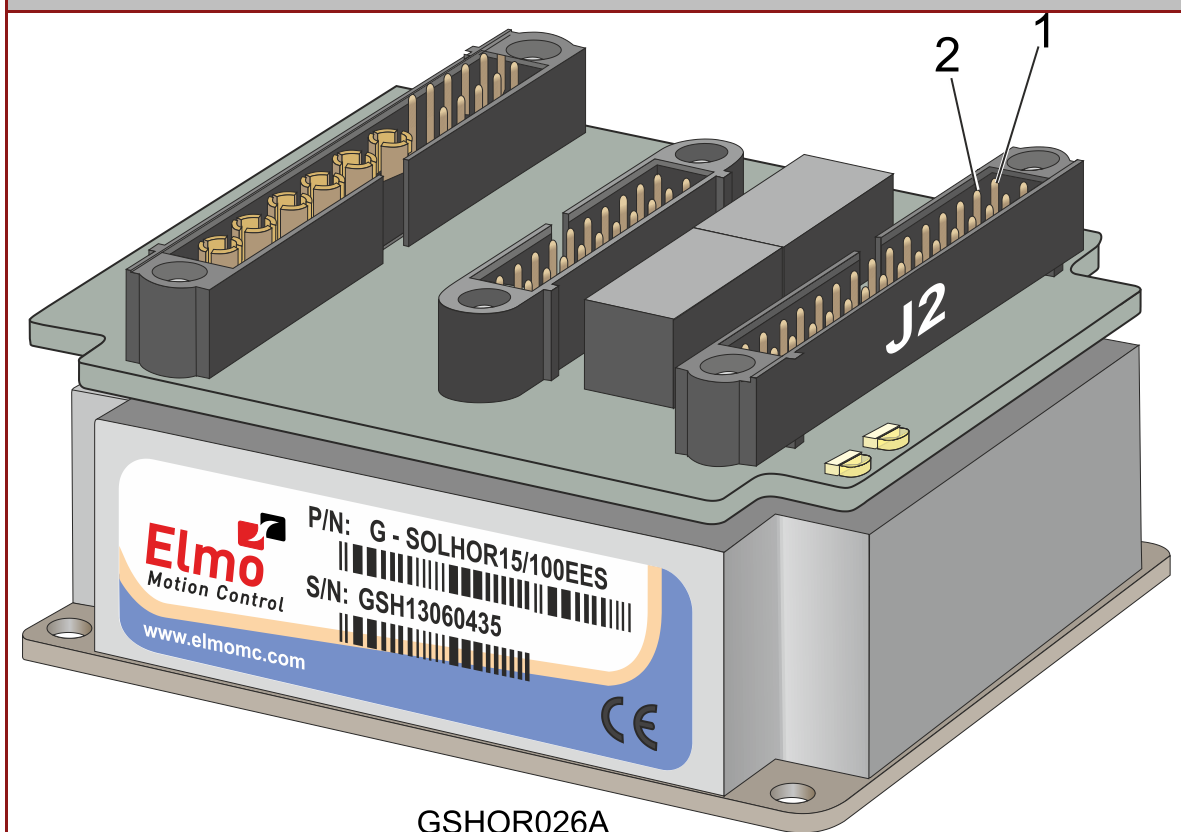

Table 4: Auxiliary Supply Pins



Caution: Power from the Gold Solo Hornet to the motor must come from the Main Supply and **NOT** from the Auxiliary Supply.

The backup functionality can be used for storing control parameters in case of power-outs, providing maximum flexibility and backup capability when needed.

Connect the VL+ and PR terminal to the **Auxiliary Supply Connector(J2)**.



To connect the auxiliary supply:

1. The source of the Auxiliary Supply must be isolated.
2. For safety reasons, connect the return (common) of the auxiliary supply source to the closest ground near the auxiliary supply source.
3. Connect the cable shield to the closest ground near the auxiliary supply source.
4. Before applying power, first verify the polarity of the connection.

A cable kit containing a cable that connects to the auxiliary supply connector (J2) is available, see Section 3.1.1 for more details.

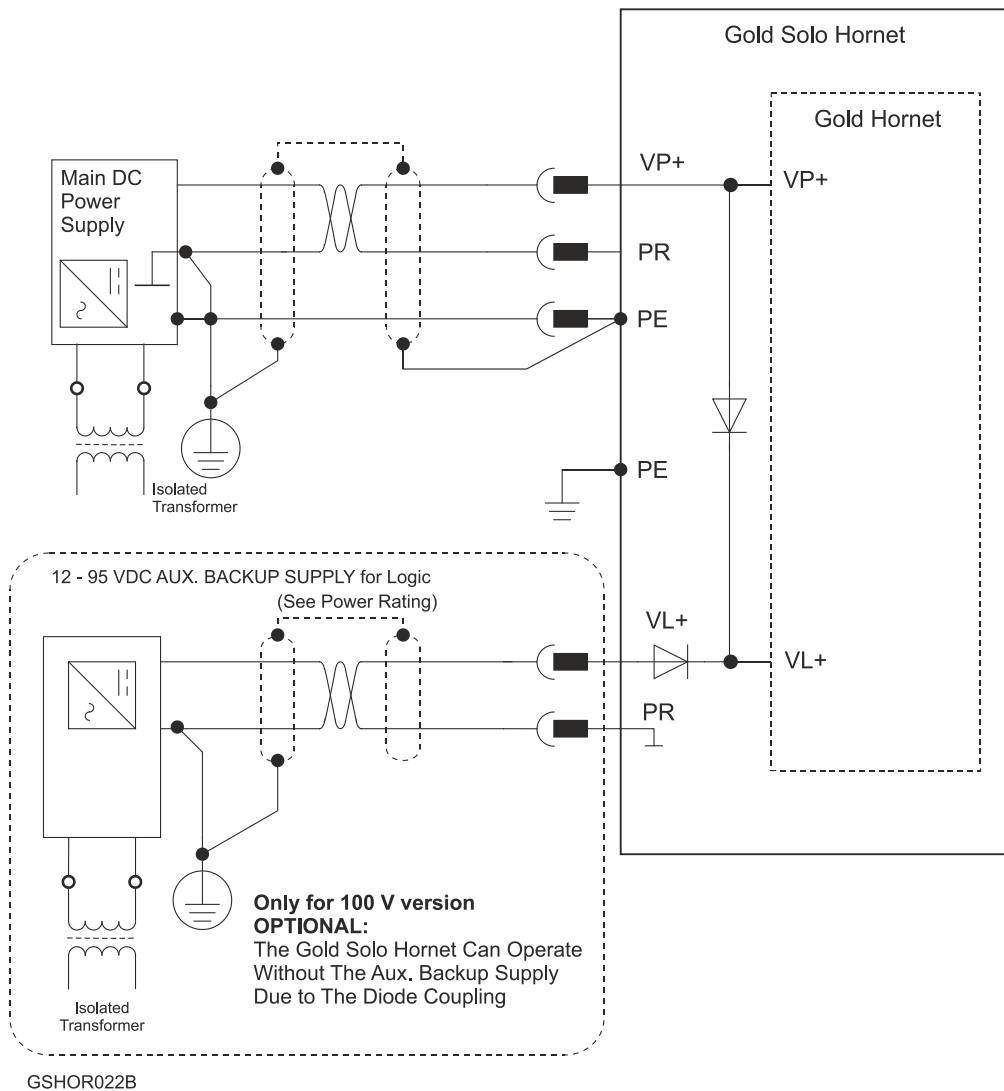

Figure 11: Auxiliary Backup Supply (Optional) Connection Diagram



6.3.2. Hall (Port A)

See Sections 10.3 in the in the MAN-G-Panel Mounted Drives Hardware manual for full details.

The following figure describes the connections at J1 for the Hall Sensor.

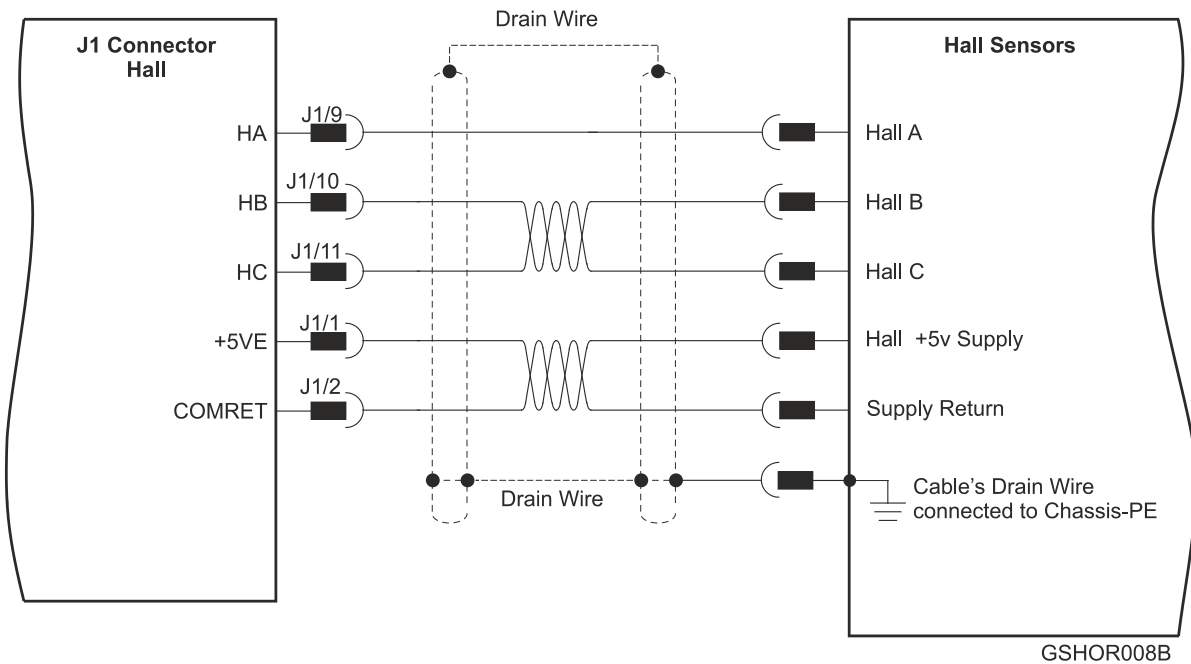

Figure 12: Hall Sensor Connection Diagram



6.3.3. Incremental, Interpolated, Encoder and Port B

See Sections 10.4 in the in the MAN-G-Panel Mounted Drives Hardware manual for full details.

6.3.3.1. Incremental Encoder

The following figure describes the connections at Port B for the Incremental encoder.

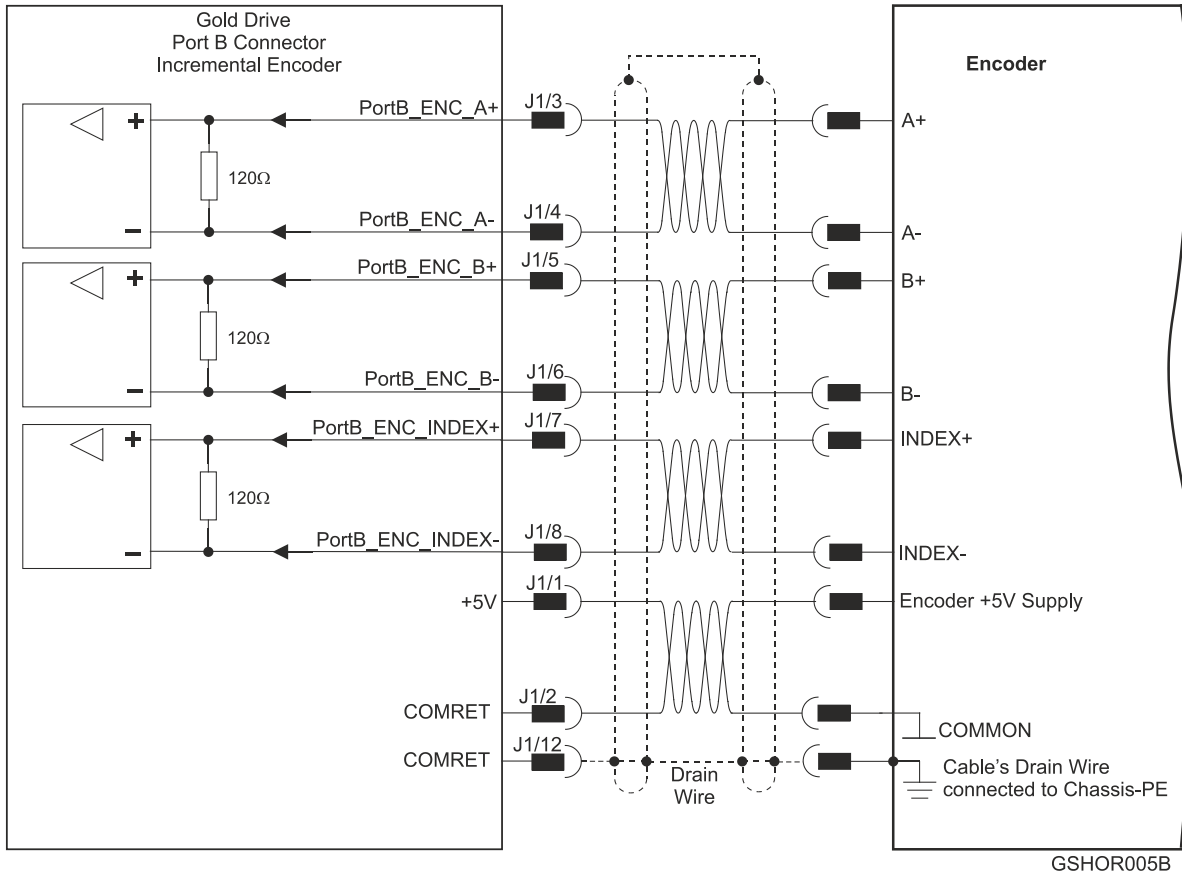

Figure 13: Port B Incremental Encoder Input – Recommended Connection Diagram



6.3.3.2. Interpolated Analog Encoder

See Sections 10.4 in the in the MAN-G-Panel Mounted Drives Hardware manual for full details.

The following figure describes the connections at Port B for the Interpolated Analog encoder.

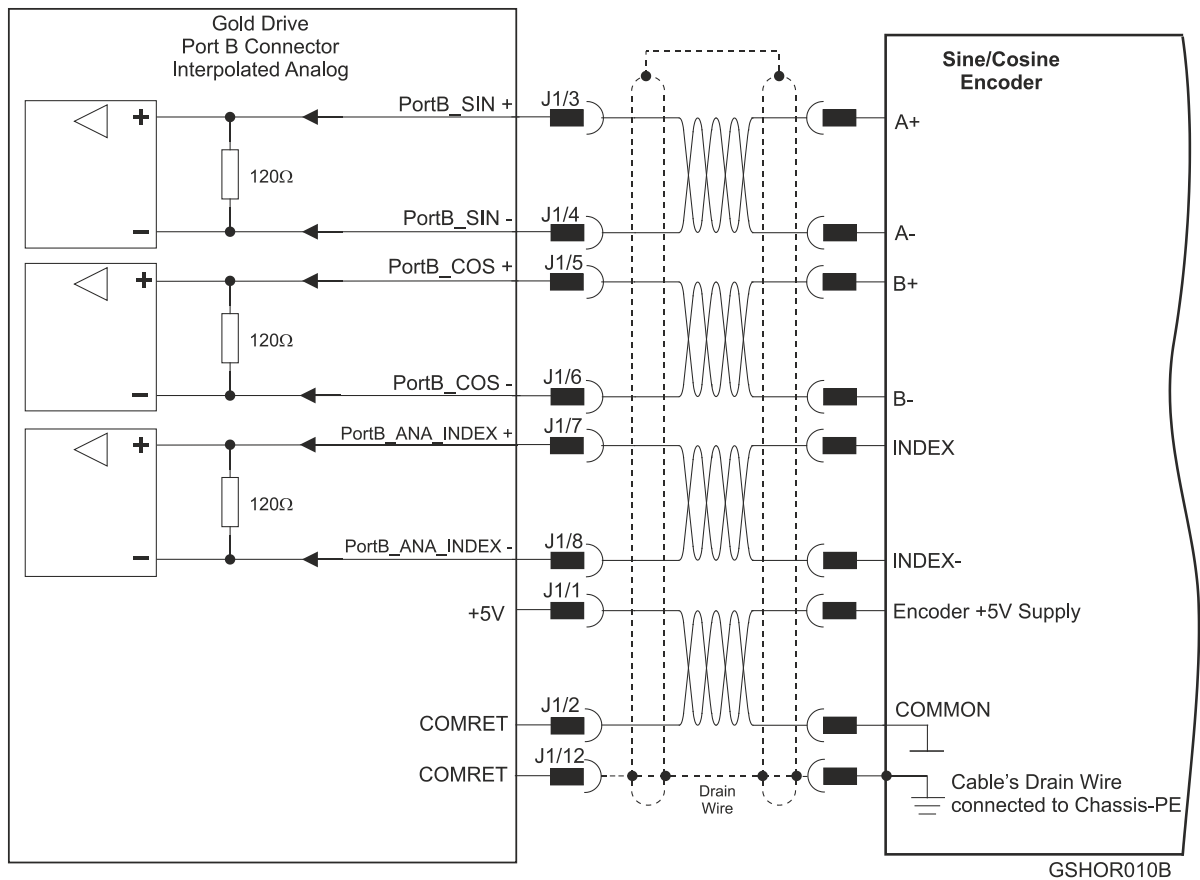

Figure 14: Port B - Interpolated Analog Encoder Connection Diagram



6.3.3.3. Resolver

See Sections 10.4 in the in the MAN-G-Panel Mounted Drives Hardware manual for full details.

The following figure describes the connections at Port B for the Resolver encoder.

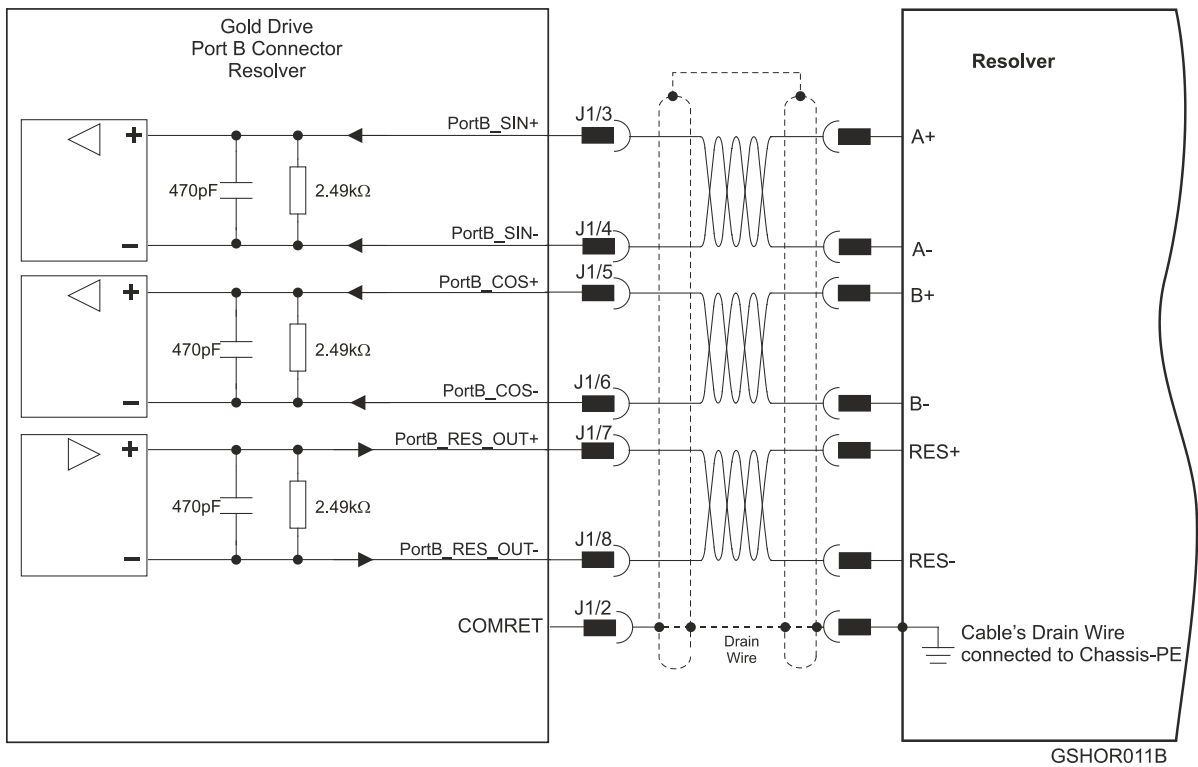

Figure 15: Port B – Resolver Connection Diagram



6.4. Connector J2 Pinouts

The J2 connector includes the following functions:

- **Port A:** Refer to Section 10.3 in the in the MAN-G-Panel Mounted Drives Hardware manual for full details.
- **Port C:** Refer to Section 10.5 in the in the MAN-G-Panel Mounted Drives Hardware manual for full details
- **Digital Input:** Refer to Section 11.1.3.1 in the in the MAN-G-Panel Mounted Drives Hardware manual for full details of the TTL option, and Section 11.1.4.1 for full details of the PLC Source option.
- **Digital Output:** Refer to Section 6.4.6 in this manual for full details.
- **Analog input:** Refer to Section 11.2 in the in the MAN-G-Panel Mounted Drives Hardware manual for full details.
- **STO:** Refer to Chapter 9 in the in the MAN-G-Panel Mounted Drives Hardware manual for full details.

		Port A (J2) Incremental Encoder		Port A (J2) Absolute Serial Encoder	
		G-SOLHOR XXX/YYYYEX		G-SOLHOR XXX/YYYYRX	
Pin	Signal	Function	Signal	Function	
4	PORTA_ENC_A+	Channel A +	ABS_CLK+	Absolute Encoder Clock+	
5	PORTA_ENC_A-	Channel A -	ABS_CLK-	Absolute Encoder Clock-	
6	PORTA_ENC_B+	Channel B+	ABS_DATA+	Absolute Encoder Data+	
7	PORTA_ENC_B-	Channel B -	ABS_DATA-	Absolute Encoder Data-	
8	PORTA_ENC_INDEX+	Index+	RESERVED	Reserved	
9	PORTA_ENC_INDEX-	Index-	RESERVED	Reserved	

Common Return (J2)		
Pin	Signal	Function
16	COMRET	Common Return
3	COMRET	Common Return

Port C (J2) - Emulated Encoder Output		
Pin	Signal	Function
10	PORTC_ENCO_A-	Buffered Channel A Complement Output
11	PORTC_ENCO_A+	Buffered Channel A Output
12	PORTC_ENCO_B-	Buffered Channel B Complement Output
13	PORTC_ENCO_B+	Buffered Channel B Output
14	PORTC_ENCO_INDEX-	Buffered INDEX Complement Output
15	PORTC_ENCO_INDEX+	Buffered INDEX Output



Analog Input (J2)		
Pin	Signal	Function
17	ANALOG1-	Analog Input Complement
18	ANALOG1+	Analog Input
19	ANLRET	Analog Return

Digital I/O and STO (J2)		
Pin	Signal	Function
20	INRET	Programmable Input 1 – 6 Return
21	IN1	Programmable Input 1 (High Speed)
22	IN2	Programmable Input 2 (High Speed)
23	IN3	Programmable Input 3 (High Speed)
24	IN4	Without STO: Programmable Input 4 (High Speed)
	STO1	With STO: STO1 Input (Default 24 V)
25	IN5	Without STO: Programmable Input 5 (High Speed)
	STO2	With STO: STO2 Input (Default 24 V))
26	IN6	Without STO: Programmable Input 6 (High Speed)
	STO_RET	With STO: STO_RET
27	OUT2RET	Programmable Digital Output Return 2
28	OUT2	Programmable Digital Output 1
29	OUT1RET	Programmable Digital Output Return 1
30	OUT1	Programmable Digital Output 2

Pin Positions

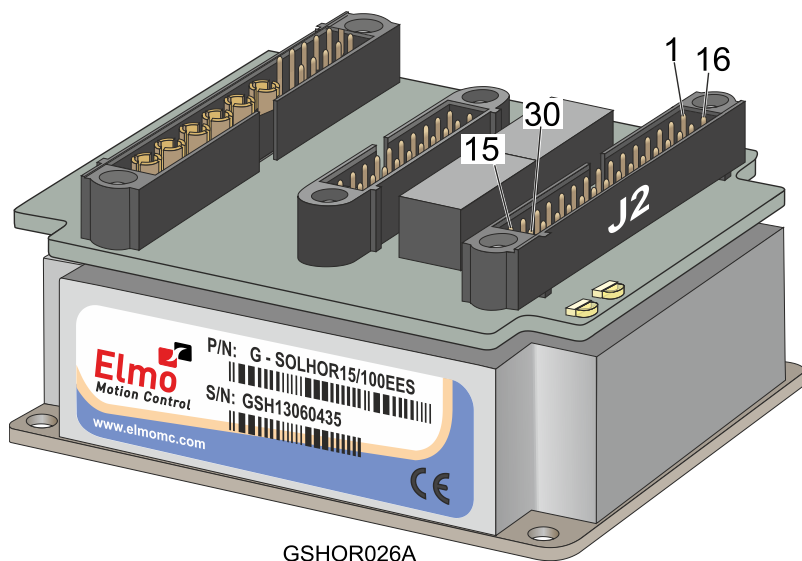

Table 5: Port A Feedback Pin Assignments



6.4.1. Port A - Incremental Encoder

Refer to Section 10.3 in the in the MAN-G-Panel Mounted Drives Hardware manual for full details.

The following figure describes the connections at Port A for the Incremental encoder.

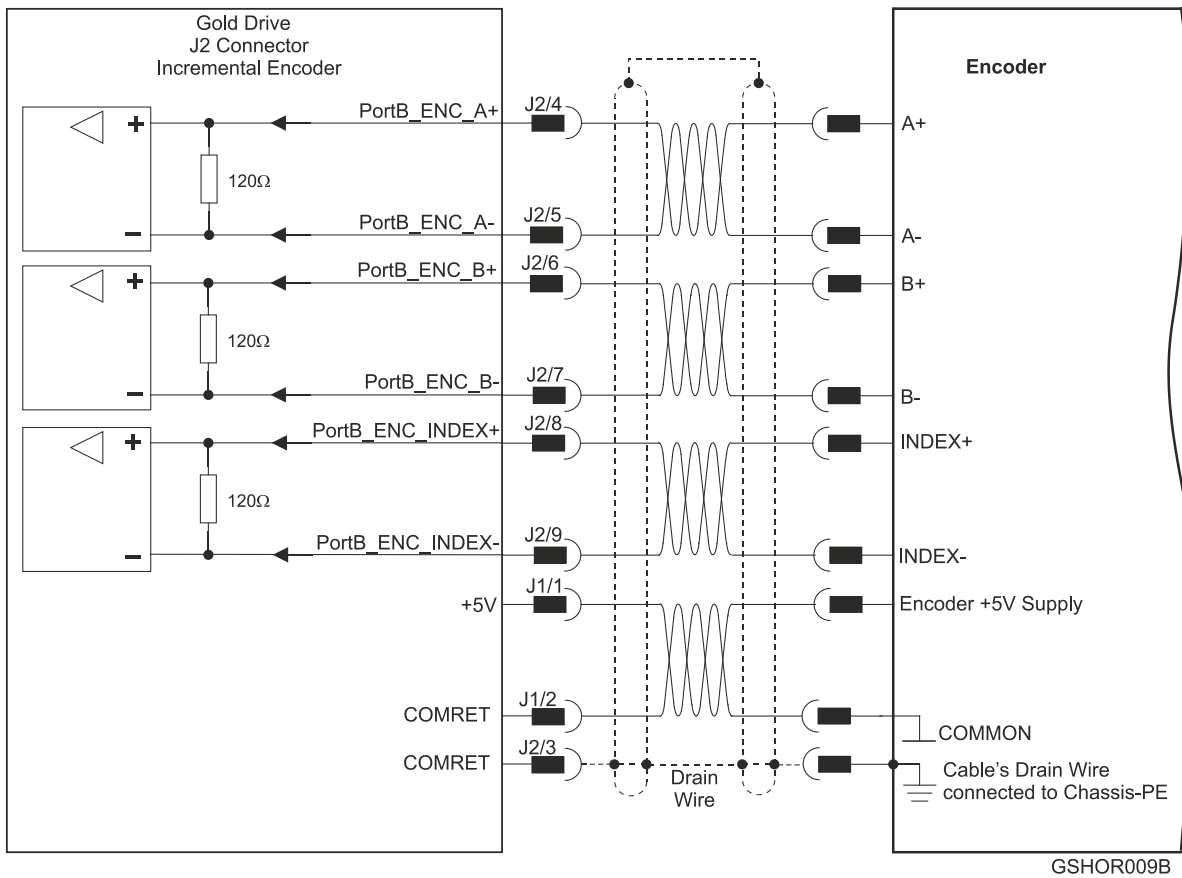

Figure 16: Port A Incremental Encoder Input – Recommended Connection Diagram



6.4.2. Port A - Absolute Serial Type Encoder

Refer to Section 10.3 in the in the MAN-G-Panel Mounted Drives Hardware manual for full details.

The following figures describe the connections at Port A for the Absolute Serial type encoders.

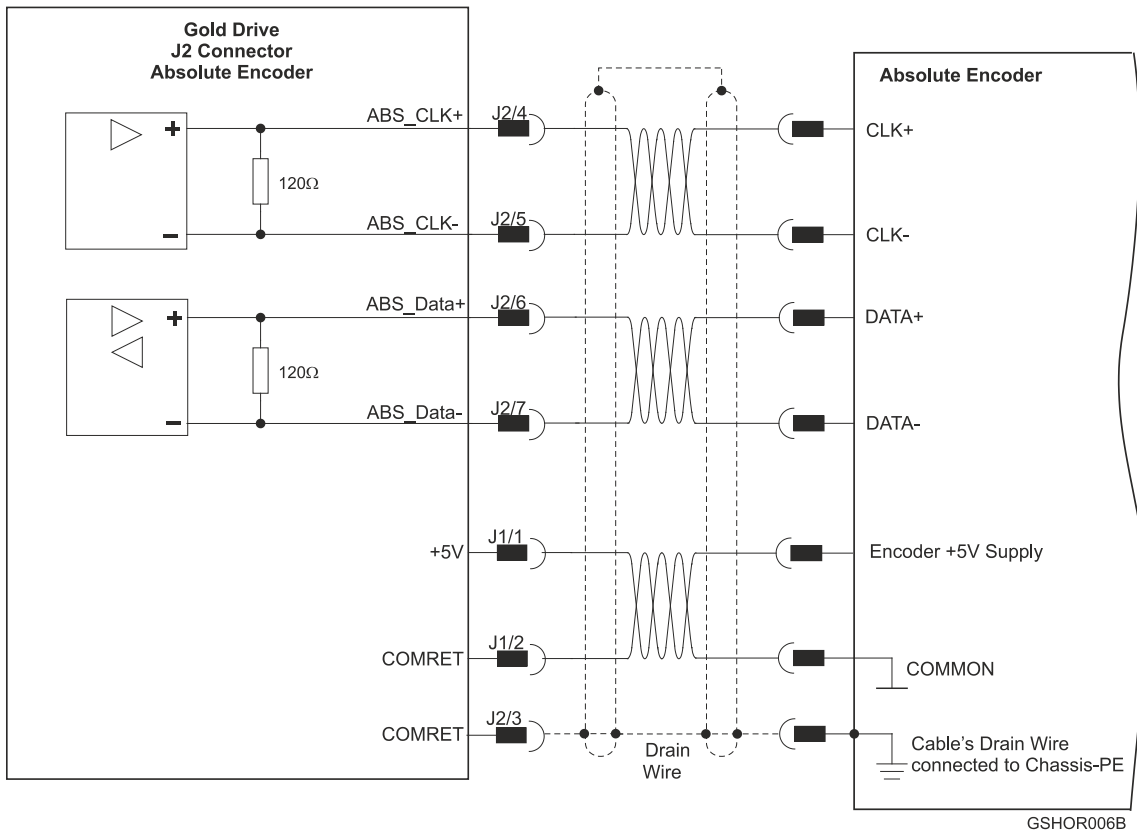

Figure 17: Absolute Serial Encoder – Recommended Connection Diagram for EnDAT, Biss, and SSI

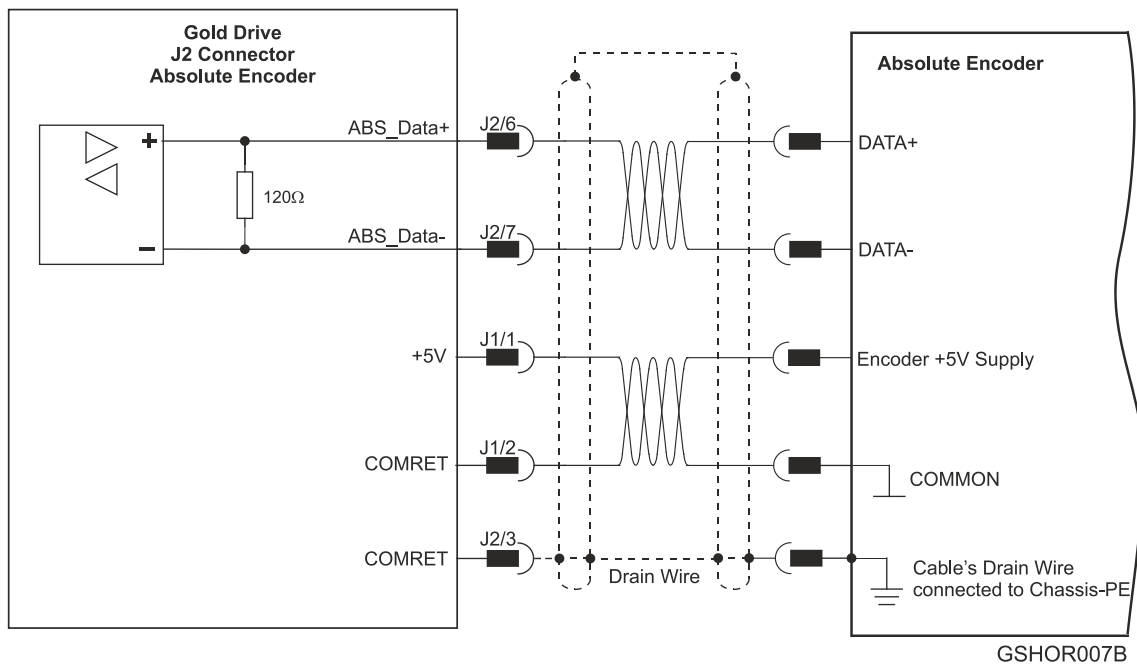

Figure 18: Absolute Serial Encoder – Recommended Connection Diagram for Sensors Supporting Data Line Only (NRZ types, e.g., Panasonic / Mitutoyo / Sanyo Danki / Tamagawa)



6.4.3. Port C - Emulated Encoder Output

Refer to Section 10.5 in the in the MAN-G-Panel Mounted Drives Hardware manual for full details

The following figure describes the connections at Port C for the Emulated Encoder Differential.

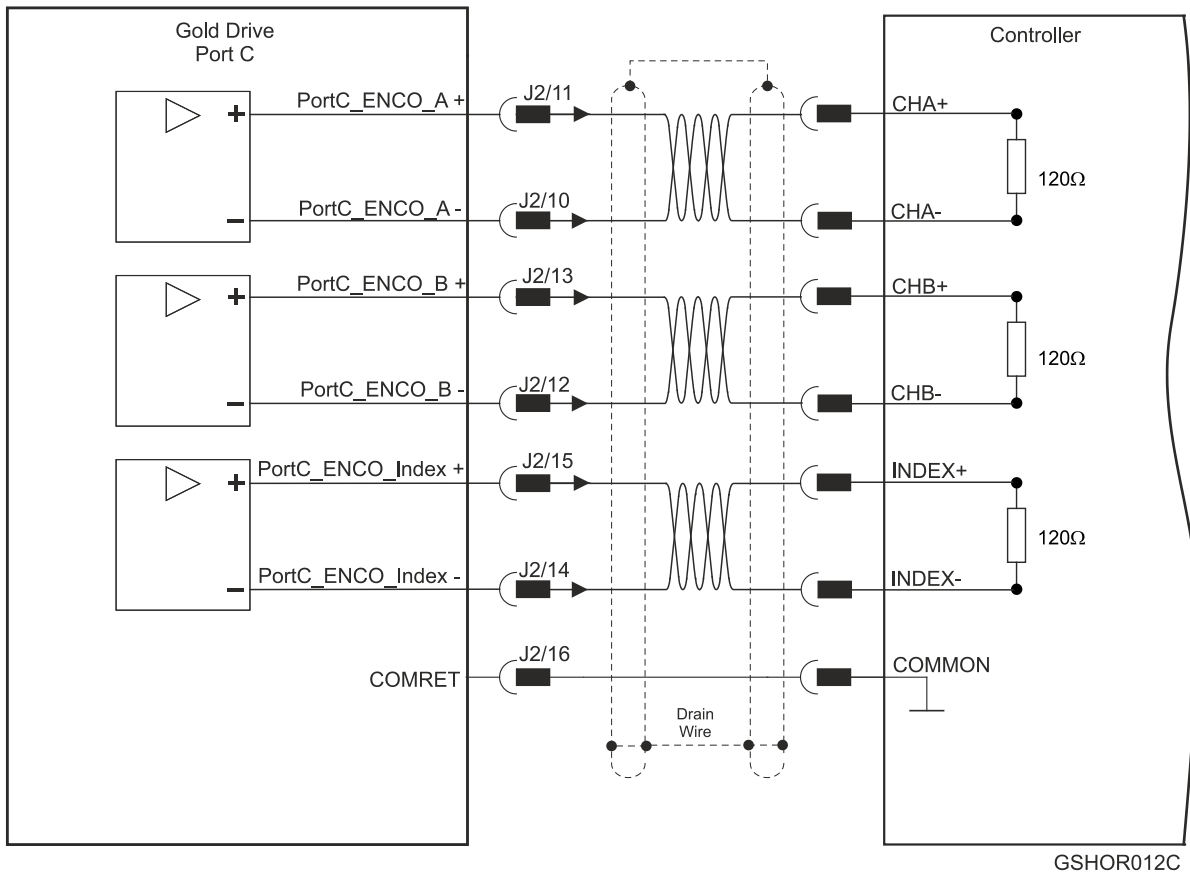

Figure 19: Emulated Encoder Differential Output – Recommended Connection Diagram

6.4.4. Analog Input

Refer to Section 11.2 in the in the MAN-G-Panel Mounted Drives Hardware manual for full details.

The following circuit describes the internal interface of the Analog input.

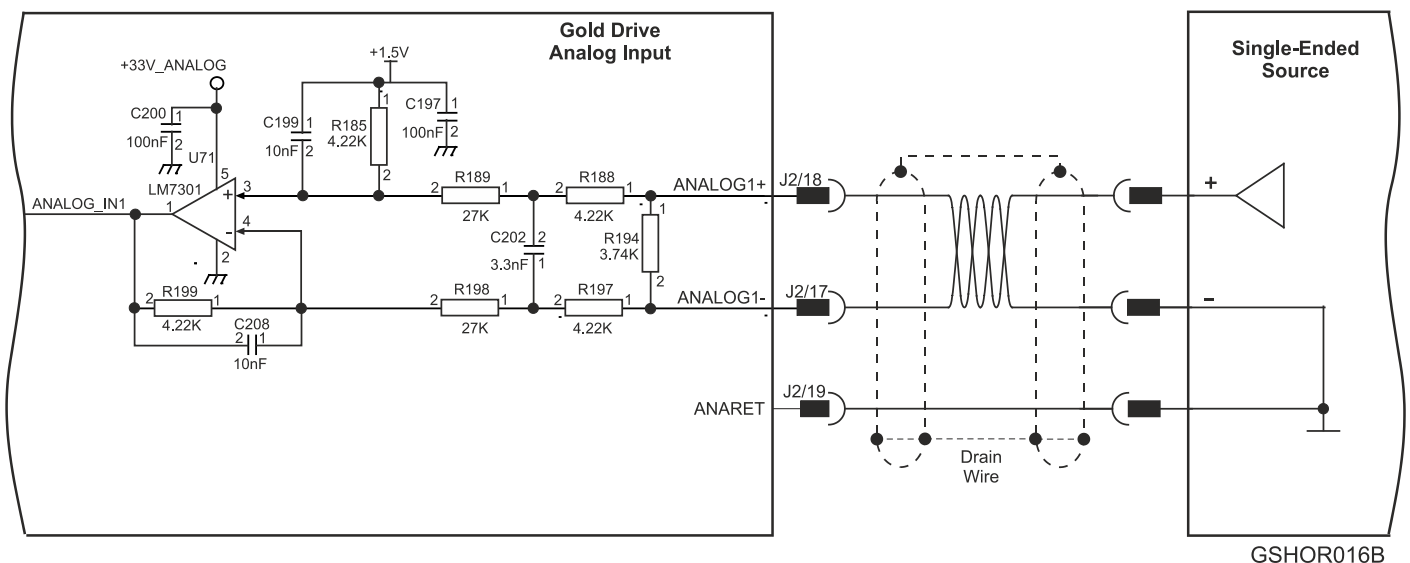

Figure 20: Differential Analog Input



6.4.5. Digital Input

6.4.5.1. Digital Input TTL Mode

Refer to Section 11.1.3.1 in the in the MAN-G-Panel Mounted Drives Hardware manual for full details of the TTL option.

The following figure describes the connections at the I/O Port for the Digital Input TTL Mode.

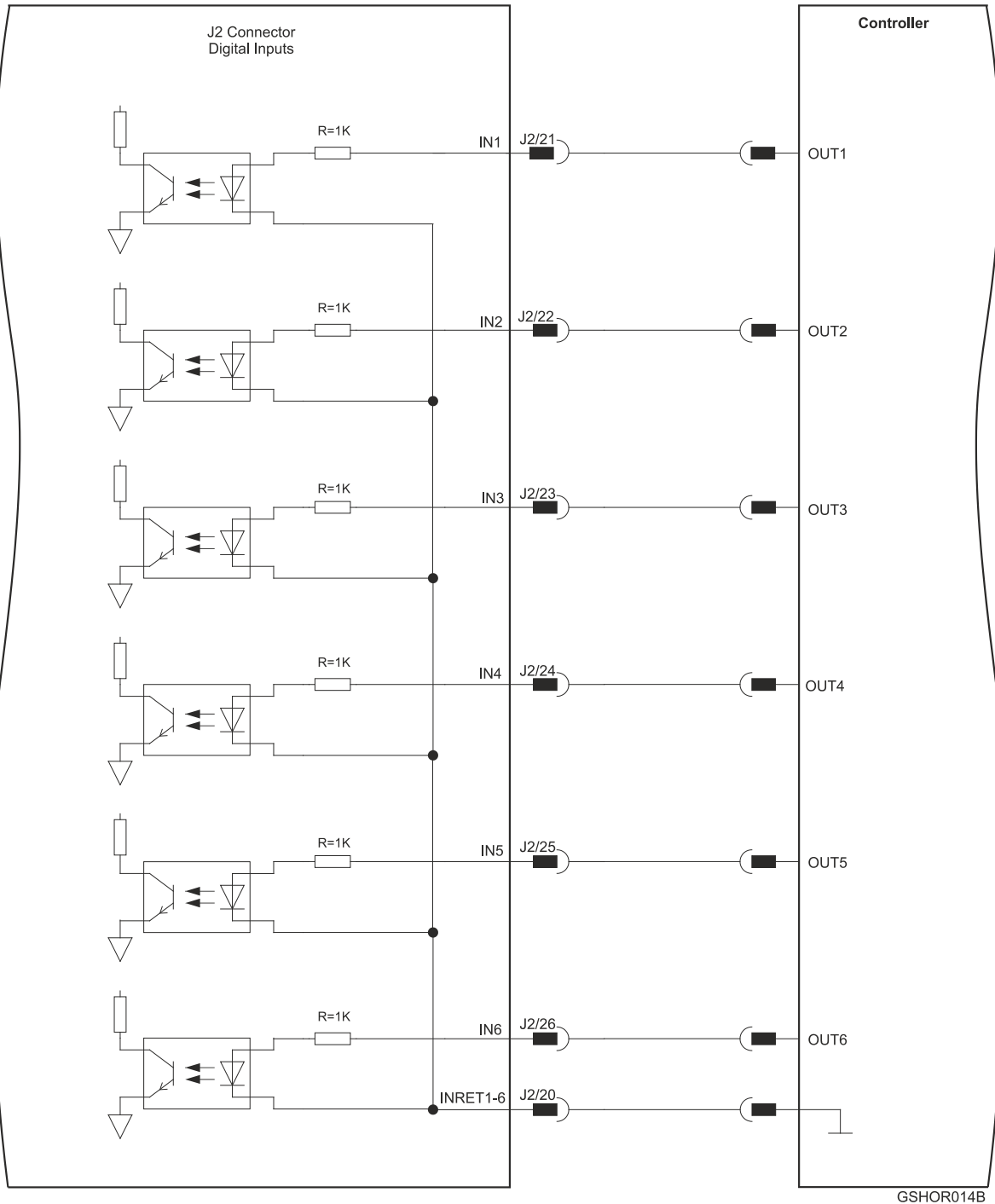

Figure 21: Digital Input TTL Mode without STO Connection Diagram

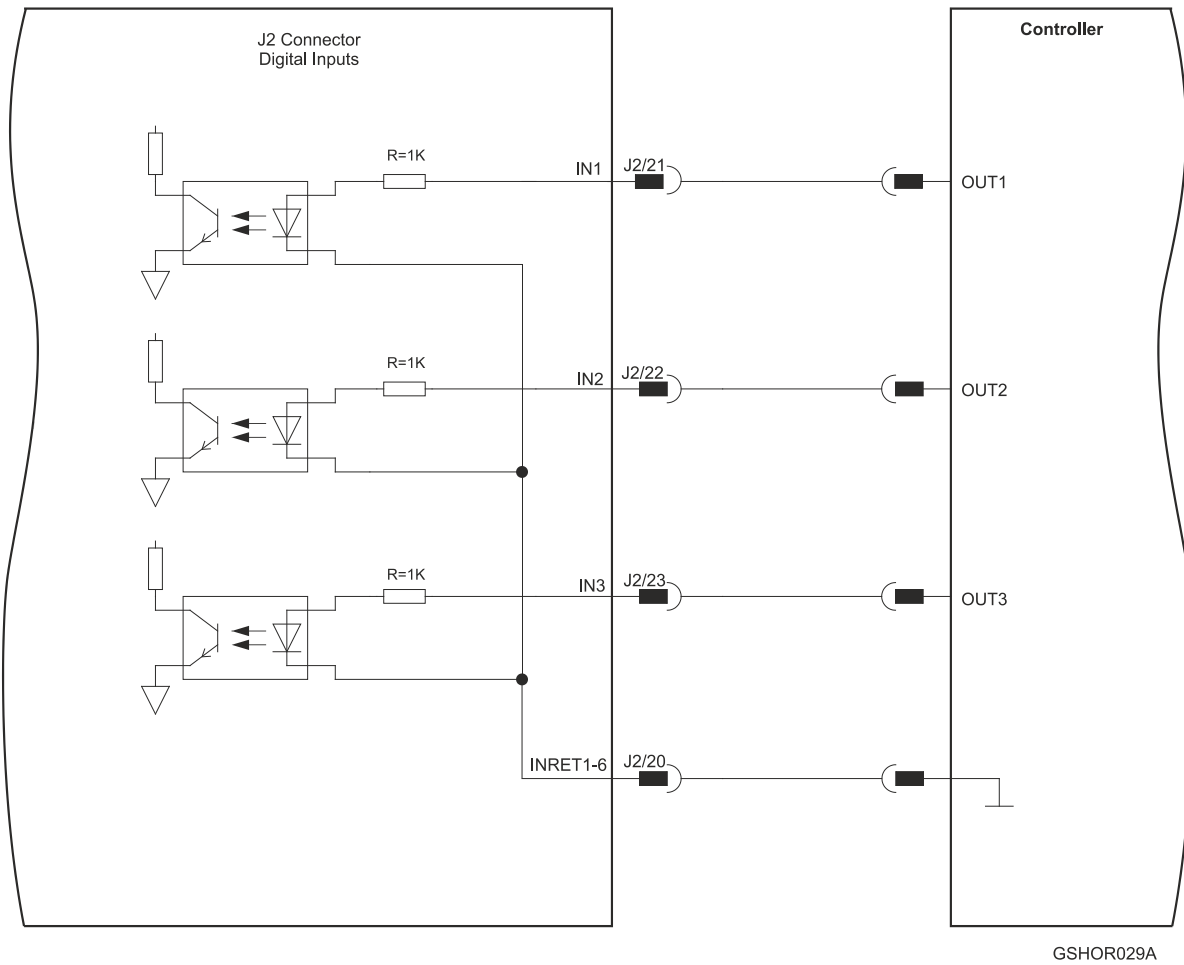

Figure 22: Digital Input TTL Mode with STO Connection Diagram



6.4.5.2. Digital Input PLC Source Mode

Refer to Section 11.1.4.1 in the in the MAN-G-Panel Mounted Drives Hardware manual for full details of the PLC Source option.

The following figure describes the connections at the I/O Port for the Digital Input PLC Mode.

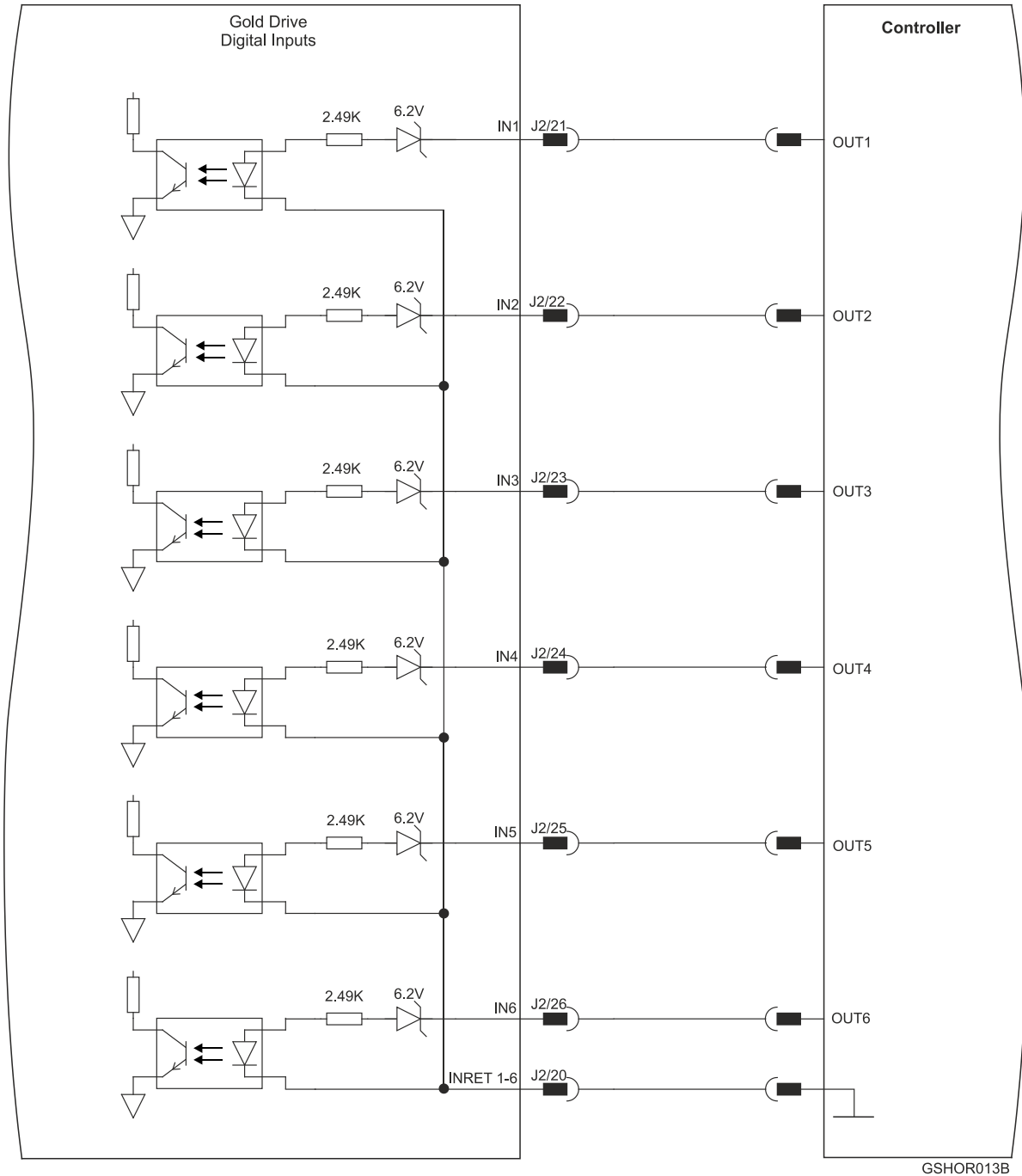

Figure 23: Digital Input Connection Diagram – Source PLC Option without STO

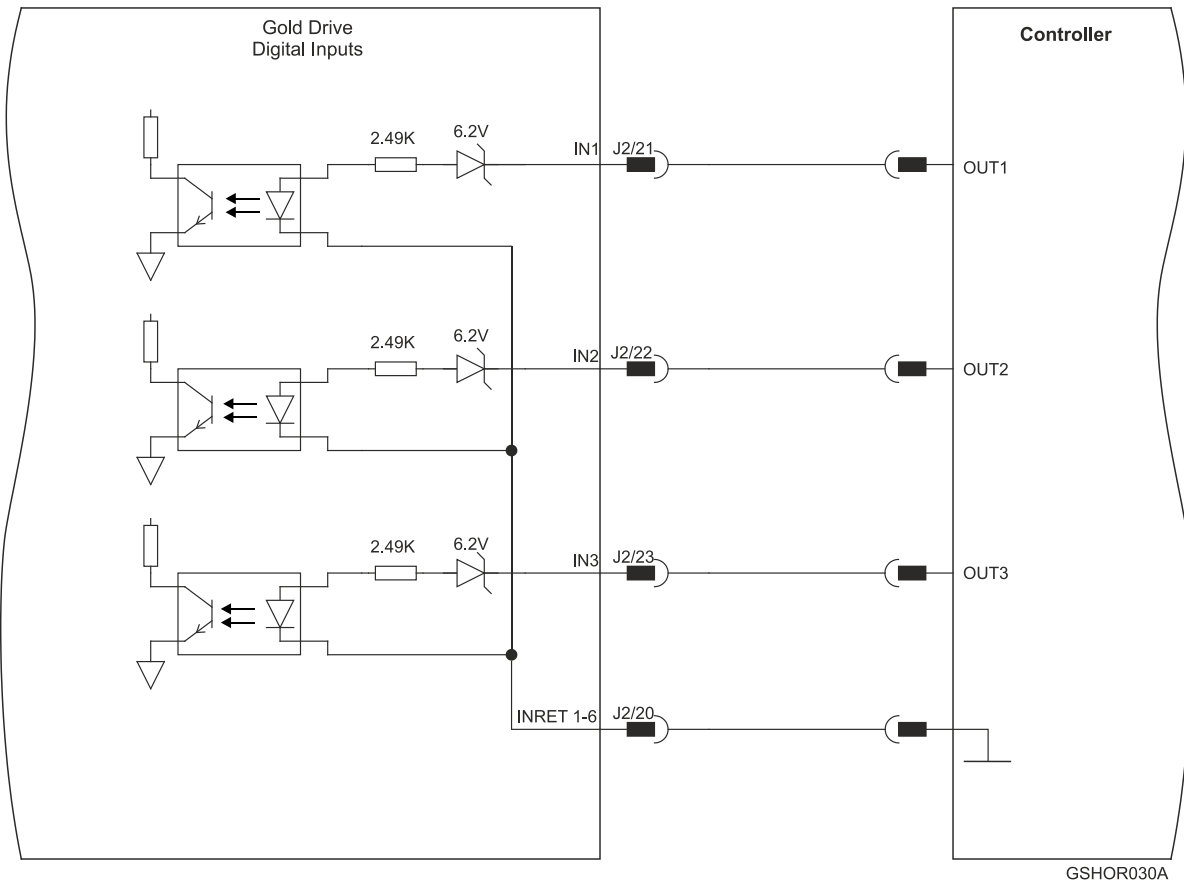

Figure 24: Digital Input Connection Diagram – Source PLC Option with STO



6.4.6. Digital Output

The Digital outputs of the G-SOLHOR are optically isolated open emitter and open collector.

The following table describes the electrical specification of the OUT1 and OUT2 outputs:

Feature	Details
Type of output	Optically isolated Source/Sink
Supply output (VCC)	5 V to 30 V
Max. output current $I_{out} (max)$ ($V_{out} = Low$)	7 mA
VOL at maximum output voltage (low level)	$V_{out} (on) \leq 0.4 V$
R_L	The external resistor R_L must be selected to limit the output current to no more than 7 mA. $R_L = \frac{VCC - VOL}{I_{out} (max)}$
Executable time	$0 < T < 250 \mu sec$
	

Figure 25: Digital Output Schematic

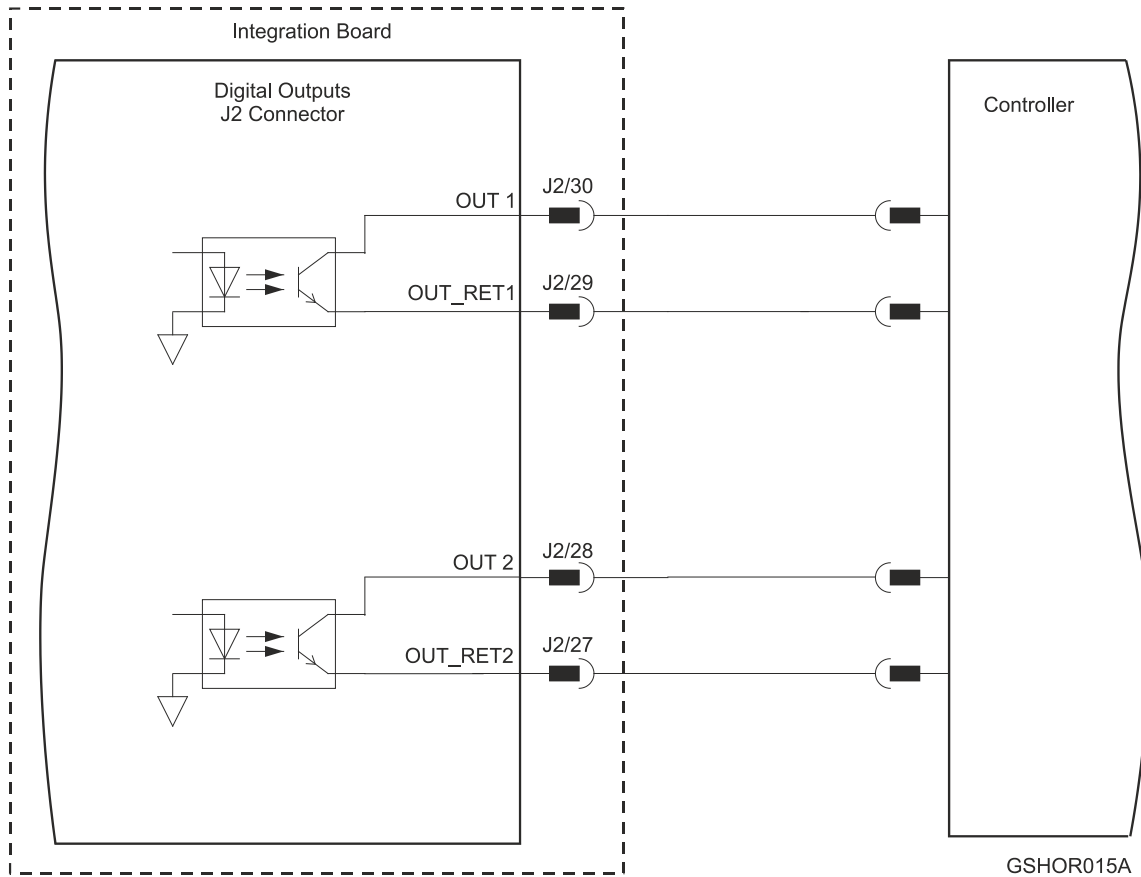

Figure 26: Digital Output Connection Diagram – TTL Option



6.4.7. STO

Refer to Chapter 9 in the in the MAN-G-Panel Mounted Drives Hardware manual for full details.

The following circuits describe the STO wiring options.

6.4.7.1. STO Source Mode PLC Voltage Level

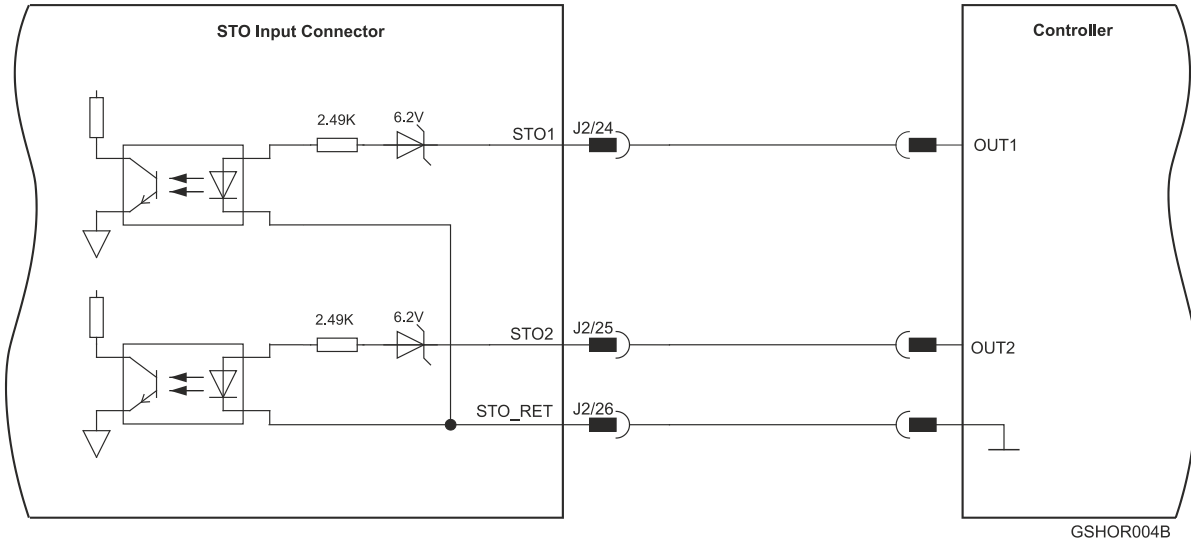

Figure 27: STO Input Connection – PLC Source Option

6.4.7.2. STO TTL Mode

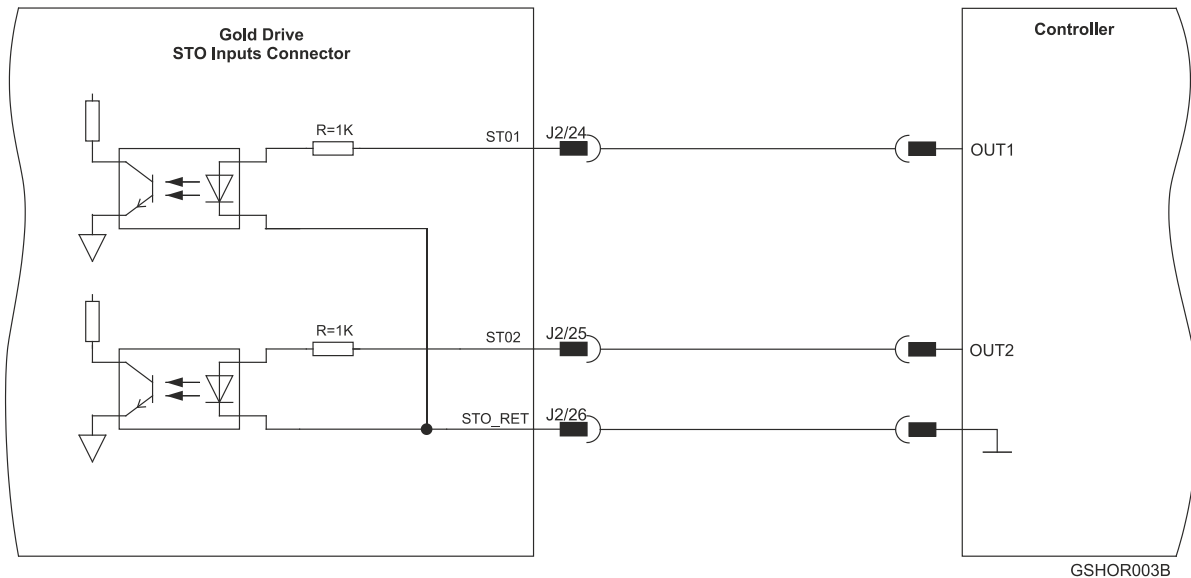

Figure 28: STO Input Connection – TTL Option



6.5. Communication Connector J3 Pinouts

The J3 connector includes the following functions:

- **RS-232:** Refer to section 12.5 in the in the MAN-G-Panel Mounted Drives Hardware manual for full details.
- **RS-422:** Refer to section 12.6 in the in the MAN-G-Panel Mounted Drives Hardware manual for full details.
- **USB:** Refer to Section 12.1 in the in the MAN-G-Panel Mounted Drives Hardware manual for full details.
- **EtherCAT or Ethernet:** Refer to section 12.2 in the MAN-G-Panel Mounted Drives Hardware manual for more details.
- **CAN:** Refer to Section 12.4 in the MAN-G-Panel Mounted Drives Hardware manual for the electrical diagram.

Note: When the EtherCAT is connected during firmware download, and FoE is in operation, the USB cable connection must be disconnected.

RS-232			Differential RS-232 (RS-422)	
Pin	Signal	Function	Signal	Function
1	RS-232_TX	RS-232 Transmit	RS-422 RX+	Differential RS-232 (RS-422) Receive
2	RS-232_RX	RS-232 Receive	RS-422_RX-	Differential RS-232 (RS-422) Receive Complement
10	-	-	RS422_TX+	Differential RS-232 (RS-422) Transmit
20	-	-	RS422_TX-	Differential RS-232 (RS-422) Transmit Complement

USB 2.0		
Pin	Signal	Function
3	USB D+	USB Data
4	USB D-	USB Data Complement
5	USB_VBUS	USB VBUS 5V
6	USB_GND	USB COM RET

EtherCAT Communications Version			CAN Communications Version	
Pin	Signal	Function	Signal	Function
8	ECAT_TX+ IN/ Ethernet_TX+	EtherCAT In Transmit or Ethernet TX	-	-
9	ECAT_TX- IN/ Ethernet_TX-	EtherCAT In Transmit Complement or Ethernet TX Complement	-	-



EtherCAT Communications Version			CAN Communications Version	
Pin	Signal	Function	Signal	Function
11	ECAT_RX+ IN/ Ethernet_RX+	EtherCAT In Receive or Ethernet RX	-	-
12	ECAT_RX- IN/ Ethernet_RX-	EtherCAT In Receive Complement or Ethernet RX Complement	-	-
14	ECAT_TX+ OUT	EtherCAT Out Transmit	CANH	CAN_H Bus Line (Dominant High)
15	ECAT_TX- OUT	EtherCAT Out Transmit Complement	CANL	CAN_L Bus Line (Dominant Low)
16	ECAT_RX+ OUT	EtherCAT Out Receive	CANH	CAN_H Bus Line (Dominant High)
17	ECAT_RX- OUT	EtherCAT Out Receive Complement	CANL	CAN_L Bus Line (Dominant Low)

Common Return		
Pin	Signal	Function
7	COMRET	Common Return
13	COMRET	Common Return
18	COMRET	Common Return
19	COMRET	Common Return

Pin Positions

GSHOR026A

Table 6: Communications Pin Assignments



6.5.1. RS-232 (J3)

Refer to section 12.5 in the in the MAN-G-Panel Mounted Drives Hardware manual for full details.

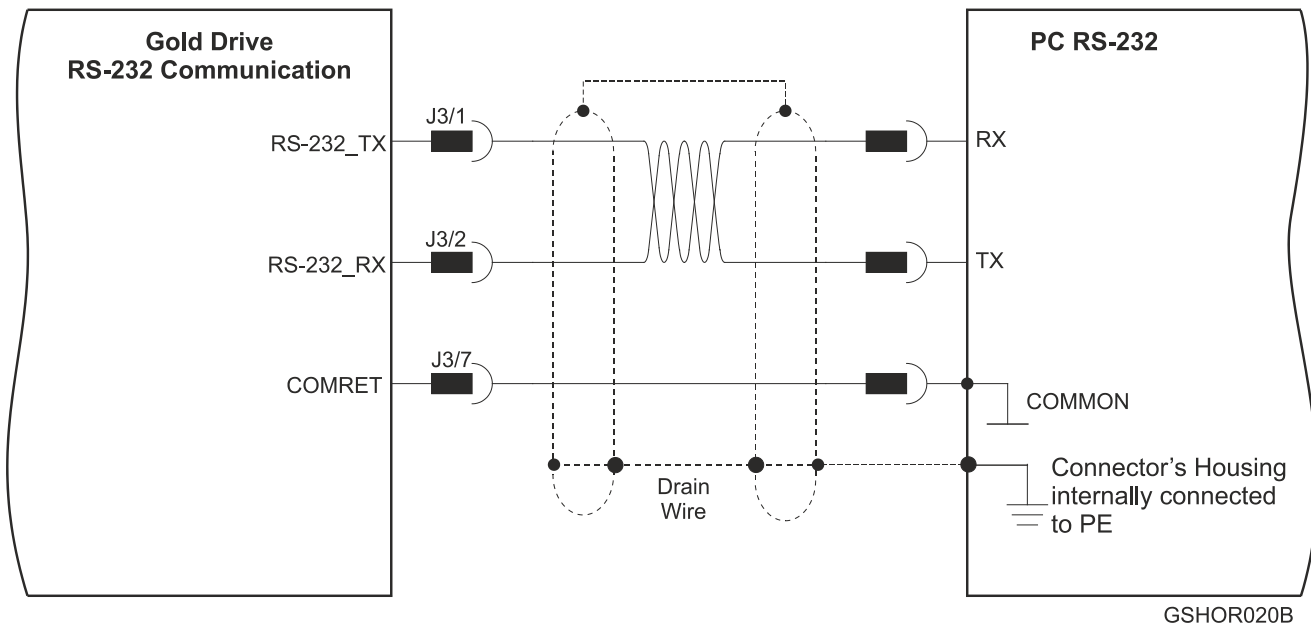
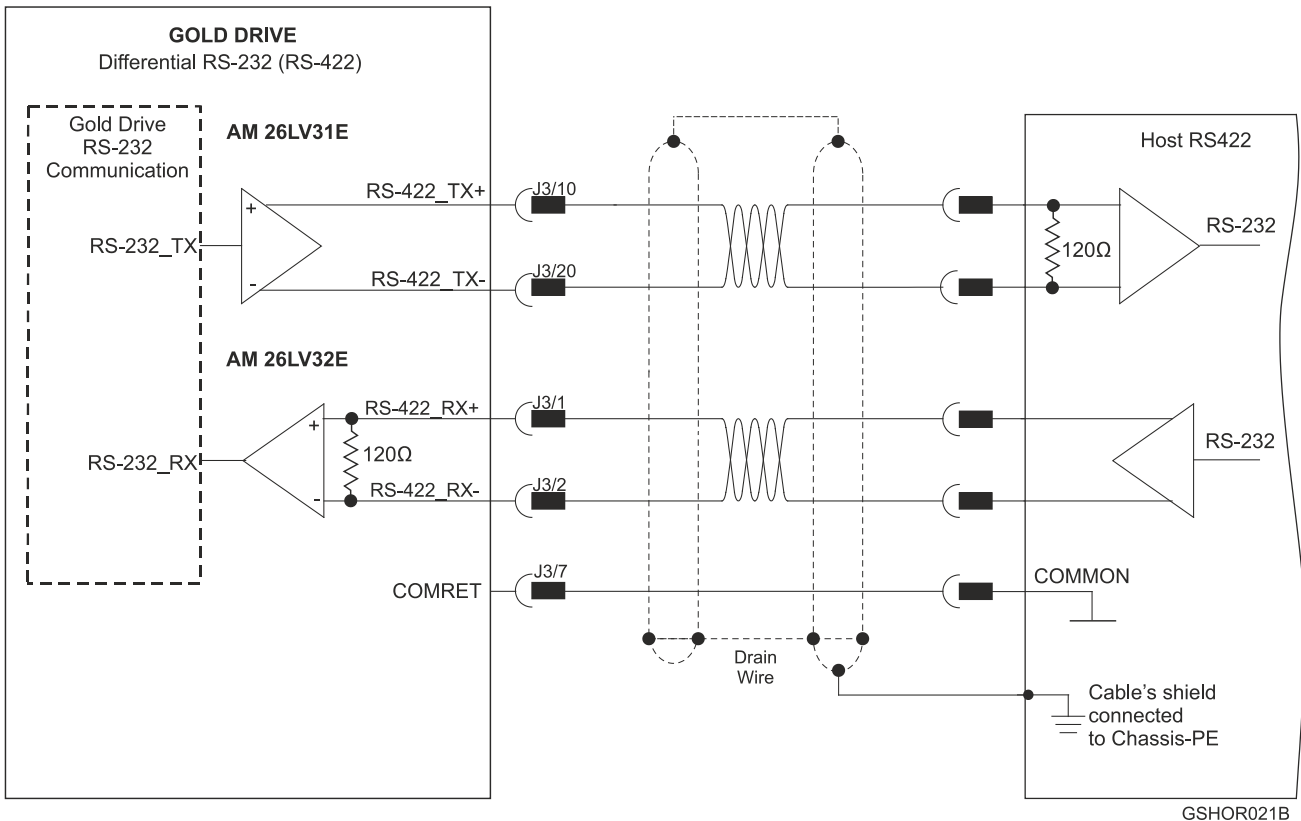

Figure 29: RS-232 Connection Diagram



6.5.2. Differential RS-232 (RS-422) (J3)

Refer to section 12.6 in the in the MAN-G-Panel Mounted Drives Hardware manual for full details.



GSHOR021B

Figure 30: RS-422 Connection Diagram



6.5.3. USB 2.0 (J3)

Refer to Section 12.1 in the in the MAN-G-Panel Mounted Drives Hardware manual for full details.

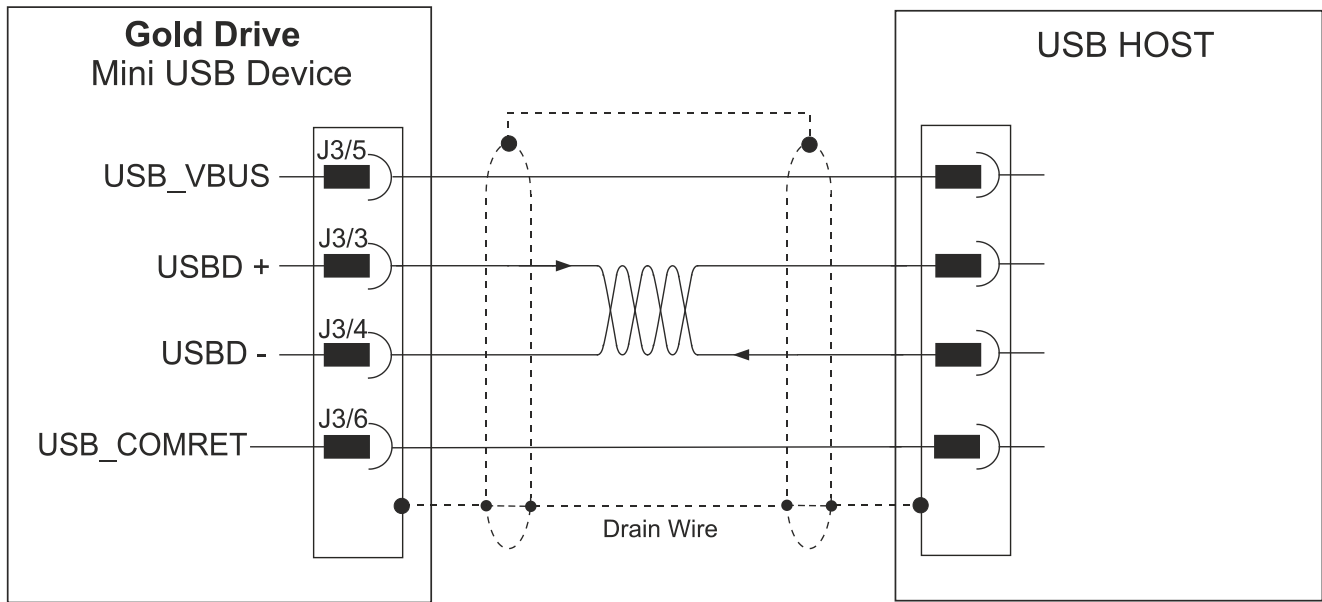

Figure 31: USB Network Diagram



6.5.4. EtherCAT Communications Version (J3)

Fieldbus communications are industrial network protocols for real-time distributed control that allows connection of servo drives.

Refer to section 12.2 in the MAN-G-Panel Mounted Drives Hardware manual for more details.

6.5.4.1. EtherCAT Status Indicator

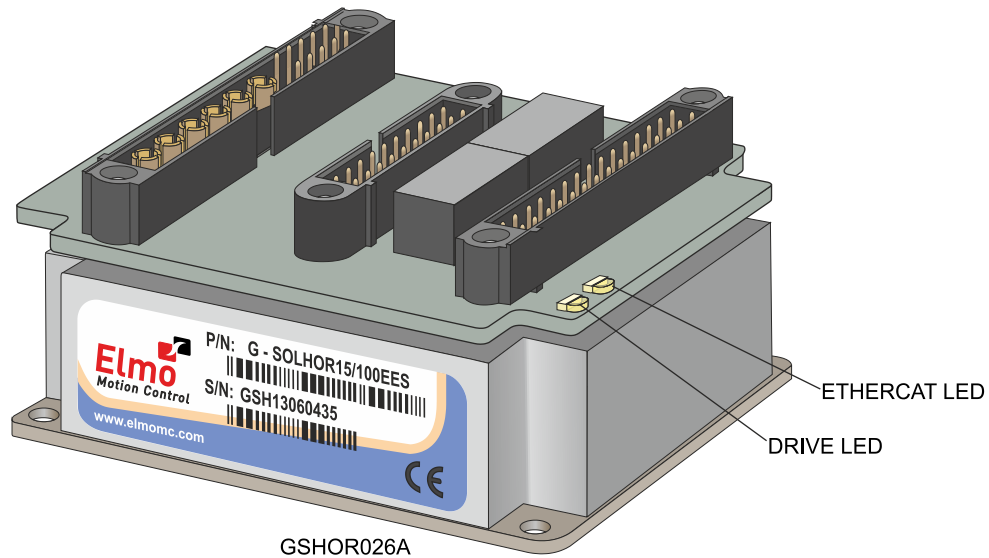

Figure 32: EtherCAT Status LED

The EtherCAT status indicator is a red/green dual LED. It combines run indication (when it is green) and error indication (when it is red) of the EtherCAT device. For further details, see the MAN-G-Panel Mounted Drives Hardware Manual for more details.



6.5.4.2. EtherCAT Link Indicators

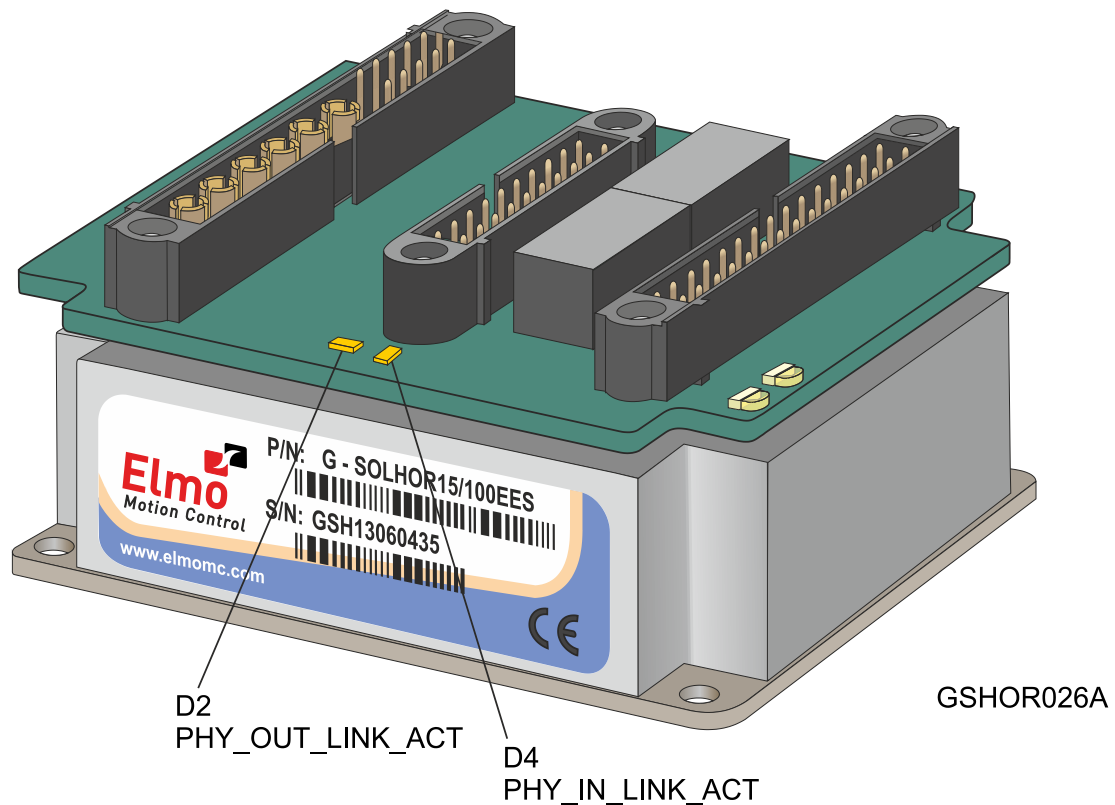

Figure 33: EtherCAT LED Link Indicators

The Gold Solo Hornet can serve as an EtherCAT slave device.

The yellow LED is the link/activity indicator. It shows the state of the applicable physical link and the activity on that link.

The possible states of these LEDs are summarized in Table 7.

LED	State	Meaning
Link/Activity	Off	No link is established.
	On	A link is established.
	Blinking	There is data transmission activity.

Table 7: LED States

6.5.5. Ethernet Communication (J3)

Refer to section 12.3 in the MAN-G-Panel Mounted Drives Hardware manual for more details.

The EtherCAT IN port can be configured as an Ethernet port for TCP/IP – see the EtherCAT Manual.



6.5.6. CAN Communications Wiring (J3)

Fieldbus communications are industrial network protocols for real-time distributed control that allows connection of servo drives. Refer to Section 12.4 in the MAN-G-Panel Mounted Drives Hardware manual for the electrical diagram. Figure 34 describes the CAN wiring diagram below.

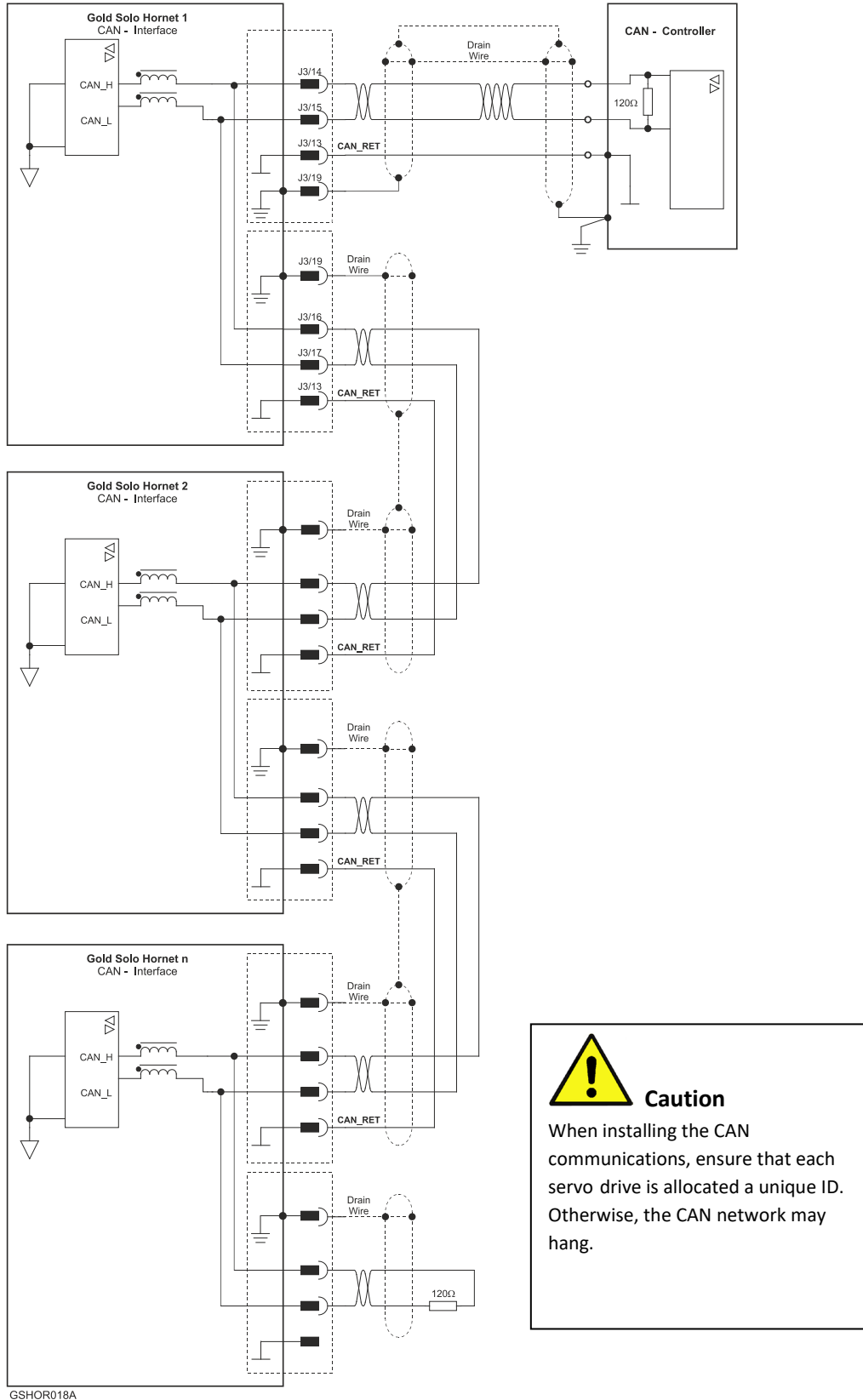

Figure 34: Gold Solo Hornet Connection Diagram – CAN



6.6. Heat Dissipation

The best way to dissipate heat from the Gold Solo Hornet is to mount it so that its heat sink faces up. For best results leave approximately 10 mm of space between the Gold Solo Hornet's heat sink and any other assembly.

6.6.1. Thermal Data

- Heat dissipation capability (θ): Approximately 10 °C/W
- Thermal time constant: Approximately 240 seconds (thermal time constant means that the Gold Solo Hornet will reach 2/3 of its final temperature after 4 minutes)
- Shut-off temperature: 86 °C to 88 °C (measured on the heat sink)

6.6.2. Heat Dissipation Data

Heat dissipation is shown in graphically below:

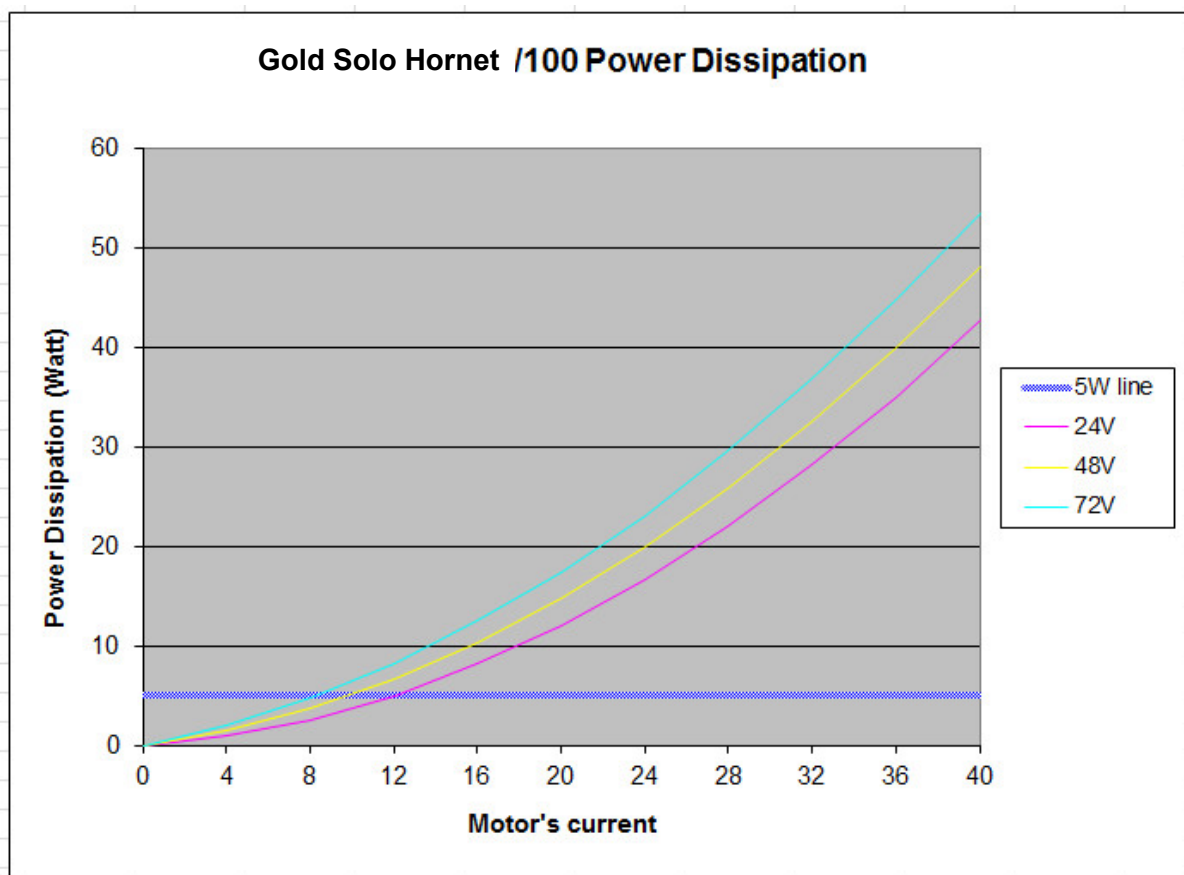

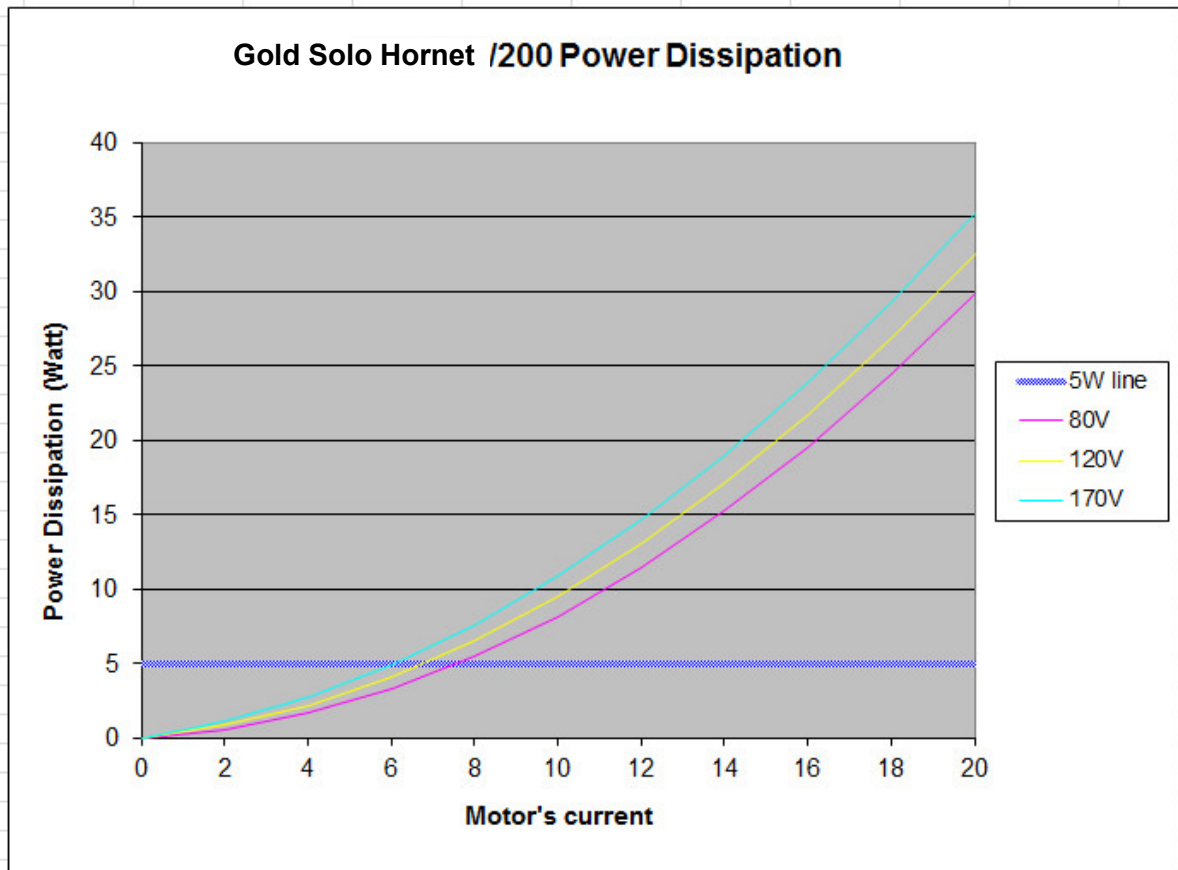

6.6.3. How to Use the Charts

The charts above are based upon theoretical worst-case conditions. Actual test results show 30% to 50% better power dissipation.

To determine if your application needs a heat sink:

1. Allow maximum heat sink temperature to be 80 °C or less.
2. Determine the ambient operating temperature of the Gold Solo Hornet.
3. Calculate the allowable temperature increase as follows:
 - For an ambient temperature of 40 °C , $\Delta T = 80^{\circ}\text{C} - 40^{\circ}\text{C} = 40^{\circ}\text{C}$
4. Use the chart to find the actual dissipation power of the drive. Follow the voltage curve to the desired output current and then find the dissipated power.
5. If the dissipated power is below 4 W the Gold Solo Hornet will need no additional cooling.

Note:

The chart above shows that no heat sink is needed when the heat sink temperature is 80 °C, ambient temperature is 40 °C and heat dissipated is 4 Watts.



Chapter 7: Powering Up

After the Gold Solo Hornet is connected to its device, it is ready to be powered up.



Caution:

Before applying power, ensure that the DC supply is within the specified range and that the proper plus-minus connections are in order.

7.1. Initializing the System

After the Gold Solo Hornet has been connected and mounted, the system must be set up and initialized. This is accomplished using the *EASII*, Elmo's Windows-based software application. Install the application and then perform setup and initialization according to the directions in the *EASII User Manual*.



Chapter 8: Dimension

This chapter provides detailed technical information regarding the Gold Solo Hornet.

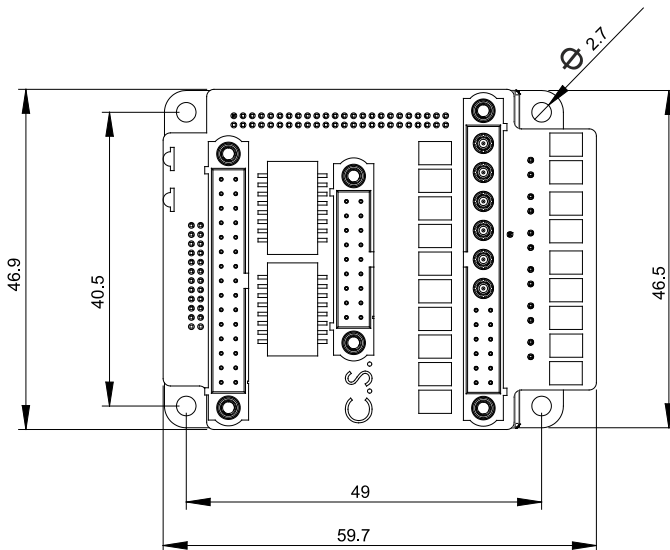
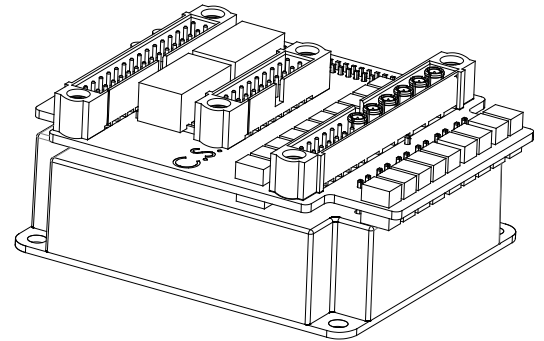
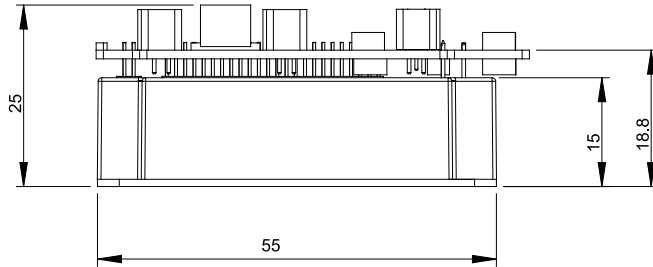

Inspiring Motion

Since 1988

For a list of Elmo's branches, and your local area office, refer to the Elmo site www.elmomc.com

