

Inspiring Motion

Since 1988

Gold Trombone Digital Servo Drive Installation Guide EtherCAT and CAN

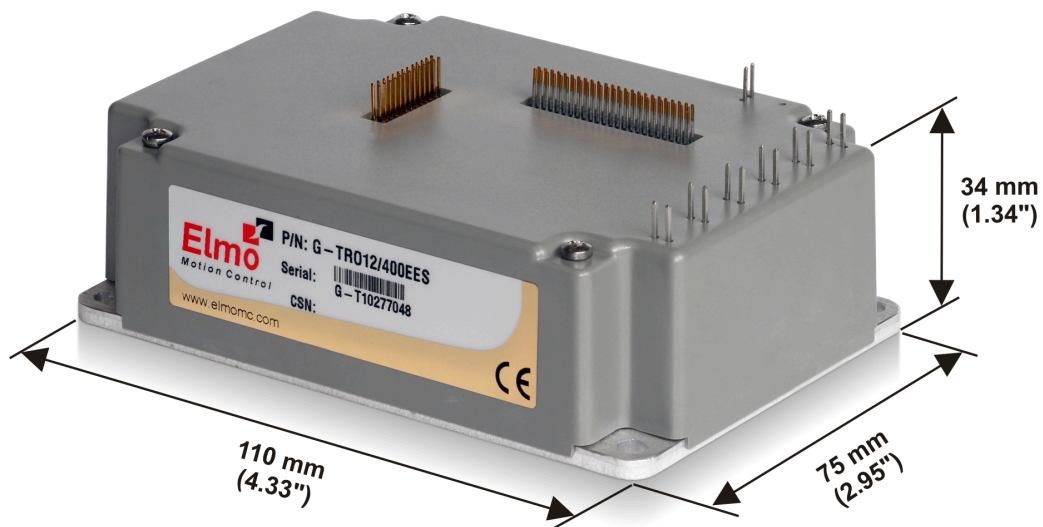

May 2016 (Ver. 1.801)

www.elmomc.com

Elmo
Motion Control

Notice

This guide is delivered subject to the following conditions and restrictions:

- This guide contains proprietary information belonging to Elmo Motion Control Ltd. Such information is supplied solely for the purpose of assisting users of the Gold Trombone servo drive in its installation.
- The text and graphics included in this manual are for the purpose of illustration and reference only. The specifications on which they are based are subject to change without notice.
- Information in this document is subject to change without notice.

Document no. MAN-G-TROIG-EC (Ver. 1.801)

Copyright © 2016

Elmo Motion Control Ltd.

All rights reserved.

Catalog Number

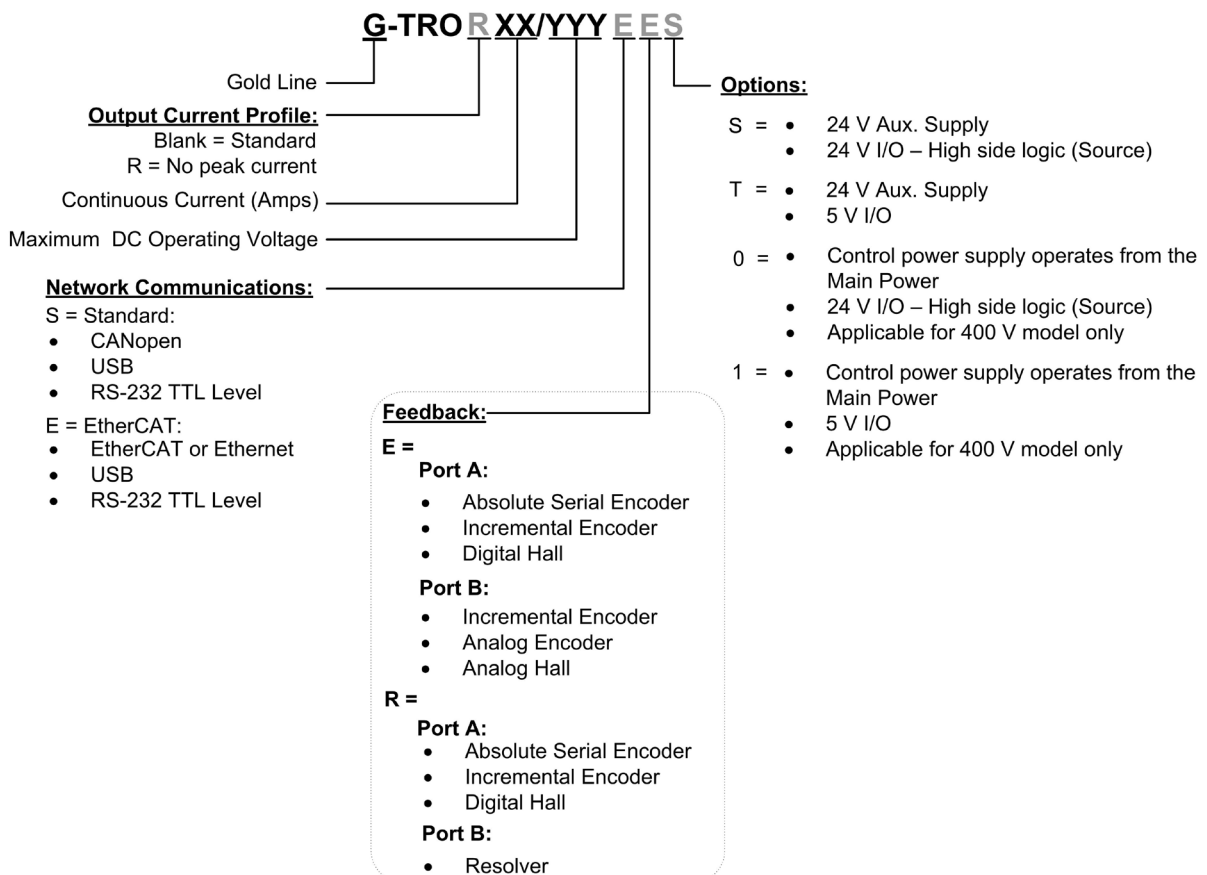



- Chapter 1: This Installation Guide5**
- Chapter 2: Safety Information5**
 - 2.1. Warnings 6
 - 2.2. Cautions..... 6
 - 2.3. CE Marking Conformance..... 6
 - 2.4. Warranty Information 6
- Chapter 3: Product Description.....7**
- Chapter 4: Technical Information.....8**
 - 4.1. Physical Specifications..... 8
 - 4.2. Technical Data 8
 - 4.2.1. Control Supply 9
 - 4.2.2. Product Features 9
 - 4.2.3. Environmental Conditions 10
 - 4.2.4. Gold Line Standards..... 11
- Chapter 5: Installation.....12**
 - 5.1. Unpacking the Drive Components 12
- Chapter 6: Mounting the Gold Trombone13**
- Chapter 7: Integrating the Gold Trombone on a PCB14**
 - 7.1. COMRET..... 14
 - 7.2. Earth Connection (PE) 14
 - 7.3. Power Conductors PCB layout..... 15
- Chapter 8: The Gold Trombone Connection Diagrams16**
- Chapter 9: PCB Connections21**
 - 9.1. Wiring legend 21
 - 9.2. Connector Types..... 23
 - 9.3. Drive Status Indicator 23
 - 9.4. Motor Power Connector Pinouts 24
 - 9.5. Main Power and Control Connector 26
 - 9.5.1. Main Power 26
 - 9.5.1.1. Direct-to-Mains Power Source 27
 - 9.5.1.2. Battery Power Supply 31
 - 9.5.2. +24 V Control Supply (J3)..... 32
 - 9.6. Connector J2 - Feedback, Analog Inputs, RS-232, USB, EtherCAT, Ethernet, and CAN 34
 - 9.6.1. Feedback Port A..... 37
 - 9.6.1.1. Incremental Encoder 37

9.6.1.2.	Hall Sensors	38
9.6.1.3.	Absolute Serial Encoder.....	39
9.6.1.4.	Hiperface	41
9.6.2.	Feedback Port B.....	42
9.6.2.1.	Incremental Encoder	42
9.6.2.2.	Interpolated Analog (Sine/Cosine) Encoder	43
9.6.2.3.	Resolver	44
9.6.3.	Port C – Emulated Encoder Output	45
9.6.4.	Analog Inputs.....	46
9.6.4.1.	Analog Input 1	46
9.6.4.2.	Analog Input 2	47
9.6.5.	RS232 TTL Logic Level	48
9.6.6.	USB 2.0	49
9.6.7.	EtherCAT/Ethernet	50
9.6.8.	CAN	51
9.7.	Connector J1 - Digital I/O, Analog Inputs, LEDs and STO	52
9.7.1.	Digital Inputs.....	54
9.7.1.1.	TTL voltage level	54
9.7.1.2.	PLC Voltage Level.....	55
9.7.2.	Digital Outputs.....	56
9.7.2.1.	TTL voltage level	56
9.7.2.2.	PLC voltage level.....	57
9.7.3.	Analog Inputs.....	58
9.7.4.	STO Input Interfaces.....	58
9.7.4.1.	TTL Mode	58
9.7.4.2.	PLC Source	59
9.7.5.	EtherCAT Status Indicator	59
Chapter 10:	Powering Up	60
10.1.	Initializing the System	60
Chapter 11:	Heat Dissipation	61
11.1.	Gold Trombone Thermal Data.....	61
11.2.	Heat Dissipation Data.....	61
11.3.	How to Use the Charts	62
Chapter 12:	Dimensions	63



Chapter 1: This Installation Guide

This installation Guide details the technical data, pinouts, and power connectivity of the Gold Trombone. For a comprehensive detailed description of the functions and connections of the Board Level Module (BLM) drive, refer to the MAN-G-Board Level Modules Hardware Manual.

Chapter 2: Safety Information

In order to achieve the optimum, safe operation of the Gold Trombone, it is imperative that you implement the safety procedures included in this installation guide. This information is provided to protect you and to keep your work area safe when operating the Gold Trombone and accompanying equipment.

Please read this chapter carefully before you begin the installation process.

Before you start, ensure that all system components are connected to earth ground. Electrical safety is provided through a low-resistance earth connection.

Only qualified personnel may install, adjust, maintain and repair the servo drive. A qualified person has the knowledge and authorization to perform tasks such as transporting, assembling, installing, commissioning and operating motors.

The Gold Trombone contains electrostatic-sensitive components that can be damaged if handled incorrectly. To prevent any electrostatic damage, avoid contact with highly insulating materials, such as plastic film and synthetic fabrics. Place the product on a conductive surface and ground yourself in order to discharge any possible static electricity build-up.

To avoid any potential hazards that may cause severe personal injury or damage to the product during operation, keep all covers and cabinet doors shut.

The following safety symbols are used in this and all Elmo Motion Control manuals:



Warning:

This information is needed to avoid a safety hazard, which might cause bodily injury or death as a result of incorrect operation.



Caution:

This information is necessary to prevent bodily injury, damage to the product or to other equipment.



Important:

Identifies information that is critical for successful application and understanding of the product.



2.1. Warnings

- To avoid electric arcing and hazards to personnel and electrical contacts, never connect/disconnect the servo drive while the power source is on.
- Power cables can carry a high voltage, even when the motor is not in motion. Disconnect the Gold Trombone from all voltage sources before servicing.
- The high voltage products within the Gold Line range contain grounding conduits for electric current protection. Any disruption to these conduits may cause the instrument to become hot (live) and dangerous.
- After shutting off the power and removing the power source from your equipment, wait at least 1 minute before touching or disconnecting parts of the equipment that are normally loaded with electrical charges (such as capacitors or contacts). Measuring the electrical contact points with a meter, before touching the equipment, is recommended.



2.2. Cautions

- The maximum DC power supply connected to the instrument must comply with the parameters outlined in this guide.
- When connecting the Gold Trombone to an approved control supply, connect it through a line that is separated from hazardous live voltages using reinforced or double insulation in accordance with approved safety standards.
- Before switching on the Gold Trombone, verify that all safety precautions have been observed and that the installation procedures in this manual have been followed.
- Make sure that the Safe Torque Off is operational

2.3. CE Marking Conformance

The Gold Trombone is intended for incorporation in a machine or end product. The actual end product must comply with all safety aspects of the relevant requirements of the European Safety of Machinery Directive 2006/42/EC as amended, and with those of the most recent versions of standards EN 60204-1 and EN ISO 12100 at the least, and in accordance with 2006/95/EC.

Concerning electrical equipment designed for use within certain voltage limits, the Gold Trombone meets the provisions outlined in 2006/95/EC. The party responsible for ensuring that the equipment meets the limits required by EMC regulations is the manufacturer of the end product.

2.4. Warranty Information

The products covered in this manual are warranted to be free of defects in material and workmanship and conform to the specifications stated either within this document or in the product catalog description. All Elmo drives are warranted for a period of 12 months from the time of installation, or 12 months from time of shipment, whichever comes first. No other warranties, expressed or implied — and including a warranty of merchantability and fitness for a particular purpose — extend beyond this warranty.



Chapter 3: Product Description

The Gold Trombone series of digital servo drives are highly resilient and designed to deliver the highest density of power and intelligence. The Gold Trombone delivers up to **10 kW of continuous power** or **16 kW of peak power** in a compact package.

The digital drives are part of Elmo's advanced Gold Line. They operate from a DC power source in current, velocity, position and advanced position modes, in conjunction with a permanent-magnet synchronous brushless motor, DC brush motor, linear motor or voice coil. They are designed for use with any type of sinusoidal and trapezoidal commutation, with vector control. The Gold Trombone can operate as a stand-alone device or as part of a multi-axis system in a distributed configuration on a real-time network.

The Gold Trombone drive is easily set up and tuned using the Elmo Application Studio (EASII) software tools. As part of the Gold product line, it is fully programmable with the Elmo motion control language. For more information about software tools refer to the Elmo Application Studio (EASII) User Guide.

Power to the Gold Trombone is provided by a direct to mains DC power source. Since the power source is fully isolated from the control supply, the DC rectifier can be fed directly from the mains, without the need for a bulky and expensive transformer.

If separation between the main DC power source and a control supply is required, then a control supply (isolated from the Mains) is required, and an S or T-model Gold Trombone should be used, with an external 24 VDC isolated supply connected to it.

Note: The control supply can operate from an isolated voltage source within the range of 18 to 30 VDC.

Whenever separation between the main DC power source and a control supply is not required, Gold Trombone models that have 0 or 1 suffix (only for 400V models) in the catalog number (see page 12) can be used, i.e., they do not have a 24 V control supply. In these models, power is provided by a DC power source which is isolated from the Mains.

The Gold Trombone is a PCB-mounted device which enables efficient and cost-effective implementation. However, stand-alone integrated products (the Gold DC Trombone and Gold Solo Trombone) are also available, using pluggable connections.



Chapter 4: Technical Information

4.1. Physical Specifications

Feature	Units	All Types
Weight	g (oz)	300 g (10.6 oz)
Dimension	mm (in)	111 x 76 x 34 (4.37" x 3" x 1.34")
Mounting method		PCB Mounted

4.2. Technical Data

Feature	Units	12/400	16/400	R17/400	R22/400	8/800	12/800	R11/800	R16/800
Minimum supply voltage	VDC	*For S or T type = 50 For 0 or 1 suffix type = 100				*For S or T type = 95			
Nominal supply voltage	VDC	325				560 for 400 VAC 680 for 480 VAC			
Maximum supply voltage	VDC	400				780			
Maximum continuous power output	W	Up to 10 kW of continuous qualitative power							
Efficiency at rated power (at nominal conditions)	%	> 98							
Control supply voltage option	VDC	18 to 30 VDC (only in S or T type)							
Control supply	VA	≤5 VA without external loading ≤8 VA with full external loading							
Continuous current limit (Ic) Amplitude sinusoidal/DC trapezoidal commutation	A	12	16	17	22	8	12	11	16
Sinusoidal continuous RMS current limit (Ic)	A	8.5	11.3	12	15.5	5.7	8.5	7.8	11.3
Peak current limit	A	2 x Ic		No peak		2 x Ic		No peak	



*See page 12 for details on the part number. The S or T suffix appears in models where there is a 24 V control supply. If there is a 0 or 1 suffix, the control power supply operates from the main power.

Note on current ratings: The current ratings of the Gold Trombone are given in units of DC amperes (ratings that are used for trapezoidal commutation or DC motors). The RMS (sinusoidal commutation) value is the DC value divided by 1.41.

4.2.1. Control Supply

Feature	Details
Control supply	<i>Isolated DC source only</i>
Control supply input voltage	18 VDC to 30 VDC
Control supply input power	< 4 VA (this includes the 5 V/200 mA load for the main encoder only) < 5.5 VA (this includes the 5 V/400 mA load on the main encoder and feedback B)

4.2.2. Product Features

Main Feature	Details	Presence and No.
STO	TTL	√
	PLC Source	√
Digital Input Option	TTL	6
	PLC Source	6
Digital Output Option	TTL	4
	PLC Source	4
Analog Input	Differential ±10V/Single Ended	1/1
Feedback	Standard Port A, B, & C	√
Communication Option	USB	√
	EtherCAT	√
	CAN	√
	RS-232 TTL level	√



4.2.3. Environmental Conditions

You can guarantee the safe operation of the Gold Trombone by ensuring that it is installed in an appropriate environment.

Feature	Details
Operating ambient temperature according to IEC60068-2-2	0 °C to 40 °C (32 °F to 104 °F)
Storage temperature	-20 °C to +85 °C (-4 °F to +185 °F)
Maximum non-condensing humidity according to IEC60068-2-78	95%
Maximum Operating Altitude	2,000 m (6562 feet) It should be noted that servo drives capable of higher operating altitudes are available on request.
Mechanical Shock according to IEC60068-2-27	15g / 11ms Half Sine
Vibration according to IEC60068-2-6	5 Hz ≤ f ≤ 10 Hz: ±10mm 10 Hz ≤ f ≤ 57 Hz: 4G 57 Hz ≤ f ≤ 500 Hz:5G



4.2.4. Gold Line Standards

The following table describes the Main Standards of the Gold Trombone servo drive. For further details refer to the MAN-G-Board Level Modules Hardware Manual.

Main Standards	Item
The related standards below apply to the performance of the servo drives as stated in the environmental conditions in section 4.2.3 Environmental Conditions above.	
STO IEC 61800-5-2:2007 SIL 3	Adjustable speed electrical power drive systems – Safety requirements – Functional
EN ISO 13849-1:2008 PL e, Cat 3	Safety of machinery — Safety-related parts of control systems.
Approved IEC/EN 61800-5-1	Adjustable speed electrical power drive systems Safety requirements – Electrical, thermal and energy
Recognized UL 508C	Power Conversion Equipment
In compliance with UL 840	Insulation Coordination Including Clearances and Creepage Distances for Electrical Equipment
Conformity with CE 2006/95/EC	Low-voltage directive 2006/95/EC
Recognized CSA C22.2 NO. 14-13	Industrial Control Equipment



Chapter 5: Installation

The Gold Trombone must be installed in a suitable environment and properly connected to its voltage supplies and the motor.

5.1. Unpacking the Drive Components

Before you begin working with the Gold Trombone, verify that you have all of its components, as follows:

- The Gold Trombone servo drive
- The Elmo Application Studio (EASII) software and user guide

The Gold Trombone is shipped in a cardboard box with Styrofoam protection.

To unpack the Gold Trombone:

1. Carefully remove the servo drive from the box and the Styrofoam.
2. Check the drive to ensure that there is no visible damage to the instrument. If any damage has occurred, report it immediately to the carrier that delivered your drive.
3. To ensure that the Gold Trombone you have unpacked is the appropriate type for your requirements, locate the part number sticker on the side of the Gold Trombone. It looks like this:



GTR000BA

4. Verify that the Gold Trombone type is the one that you ordered, and ensure that the voltage meets your specific requirements.
The part number at the top provides the type designation. Refer to the appropriate part number in the section Catalog Number at the beginning of the installation guide.



Chapter 6: Mounting the Gold Trombone

The Gold Trombone is designed for mounting on a printed circuit board (PCB). It is connected by 1.27 mm pitch 0.41 mm square pins and 2.54 mm pitch 0.64 mm square pins. When integrating the Gold Trombone into a PCB, be sure to leave about 1 cm (0.4") outward from the heat-sink to enable free convection of the air around the Gold Trombone. We recommend that the Gold Trombone be soldered directly to the board. Alternatively, though this is not recommended, the Gold Trombone can be attached to socket connectors mounted on the PCB. However, if the PCB is enclosed in a metal chassis, we recommend that the Gold Trombone be screw-mounted to it as well to help with heat dissipation. The Gold Trombone has screw-mount holes on each corner of the heat-sink for this purpose.

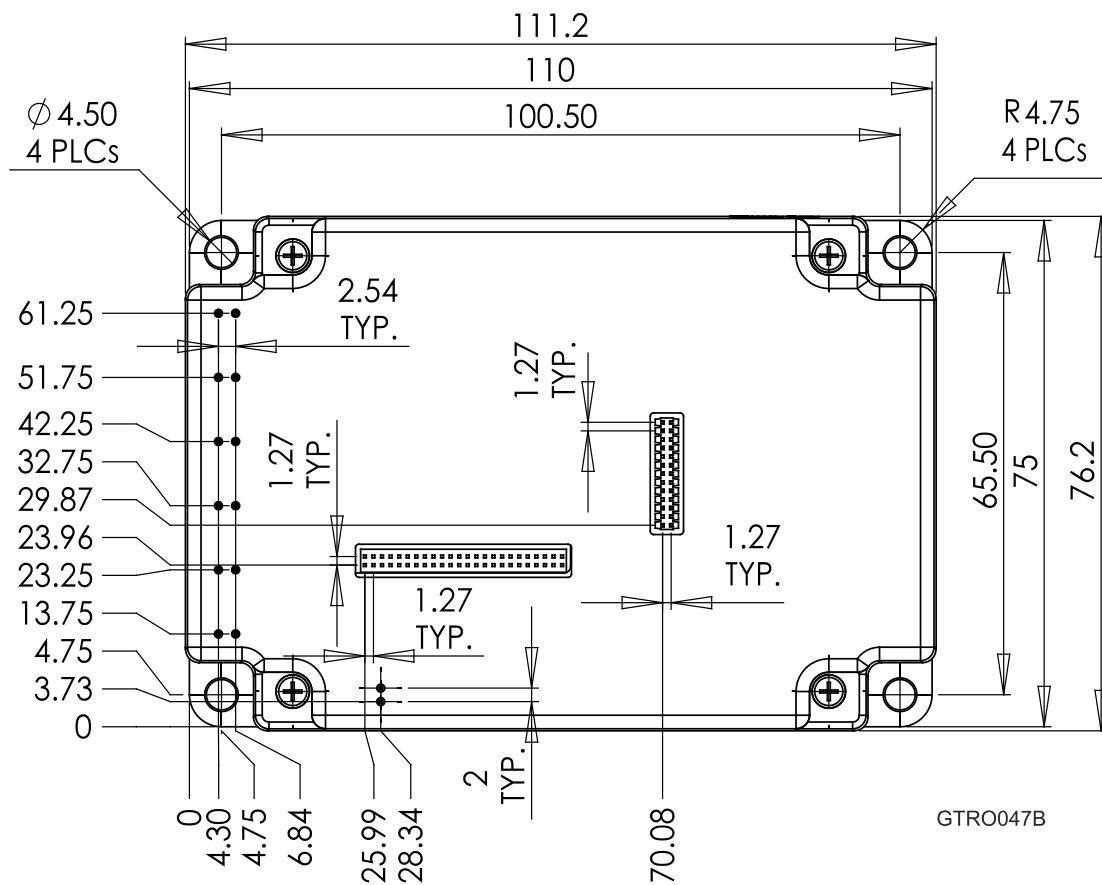

Figure 1: Gold Trombone Footprint



Chapter 7: Integrating the Gold Trombone on a PCB

The Gold Trombone is designed to be mounted on a PCB by soldering its pins directly to the PCB. Refer to the MAN-G-Board Level Modules Hardware Manual and the Gold Line Trombone Design Guide MAN-G-TROIDG for further information.

7.1. COMRET

For details of the COMRET, refer to the section 5.4 in the MAN-G-Board Level Modules Hardware Manual.

7.2. Earth Connection (PE)

The PE (Earth connection) terminal is connected internally in the drive to the Gold Trombone's chassis (heat-sink + metal cover) which serves as an EMI common plane. Any other assembly metallic parts (such as the chassis) should also be connected to the PE.

Under normal operating conditions, the PE trace carries no current. The only time these traces carry current is under unusual conditions (such as when the device has become a potential shock or fire hazard while conducting external EMI interferences directly to ground). When connected properly the PE trace prevents these hazards from affecting the drive.



7.3. Power Conductors PCB layout

The PCB virtually divided into two zones; Power Zone, and Control & Communication Zone.

- **Power Zone**
This area is dedicated to Power conductors only: VP+, VN-, PE, VL+, VL-, and motor leads.
- **Control and Communication Zone**
This area of the PCB is dedicated to Control low level signals

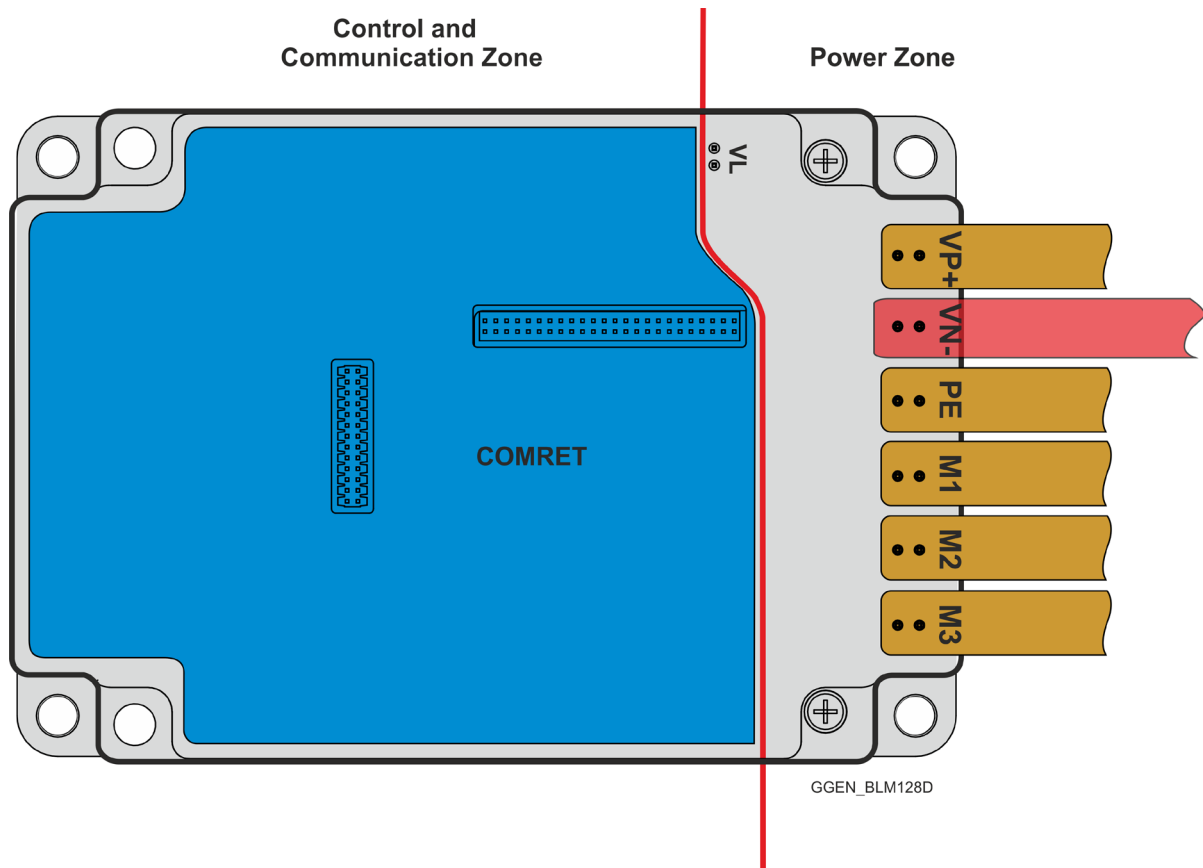

Figure 2: Gold Trombone Power Conductors PCB layout

For more details, refer to the section 5.4 in the MAN-G-Board Level Modules Hardware Manual.



Chapter 8: The Gold Trombone Connection Diagrams

There are two connection diagrams for EtherCAT and two for CAN that show the two different ways of connecting the power supply:

- 400 V and 800 V S or T -models (the catalog number has an S or T suffix) that require a 24 V control supply. The drive will not be operative without the external 24 VDC supply.
- 400 V model without the control supply (0 or 1 suffix). The drive's internal DC/DC converter is fed from the VP+ and VN- of the internal drive's bus line.

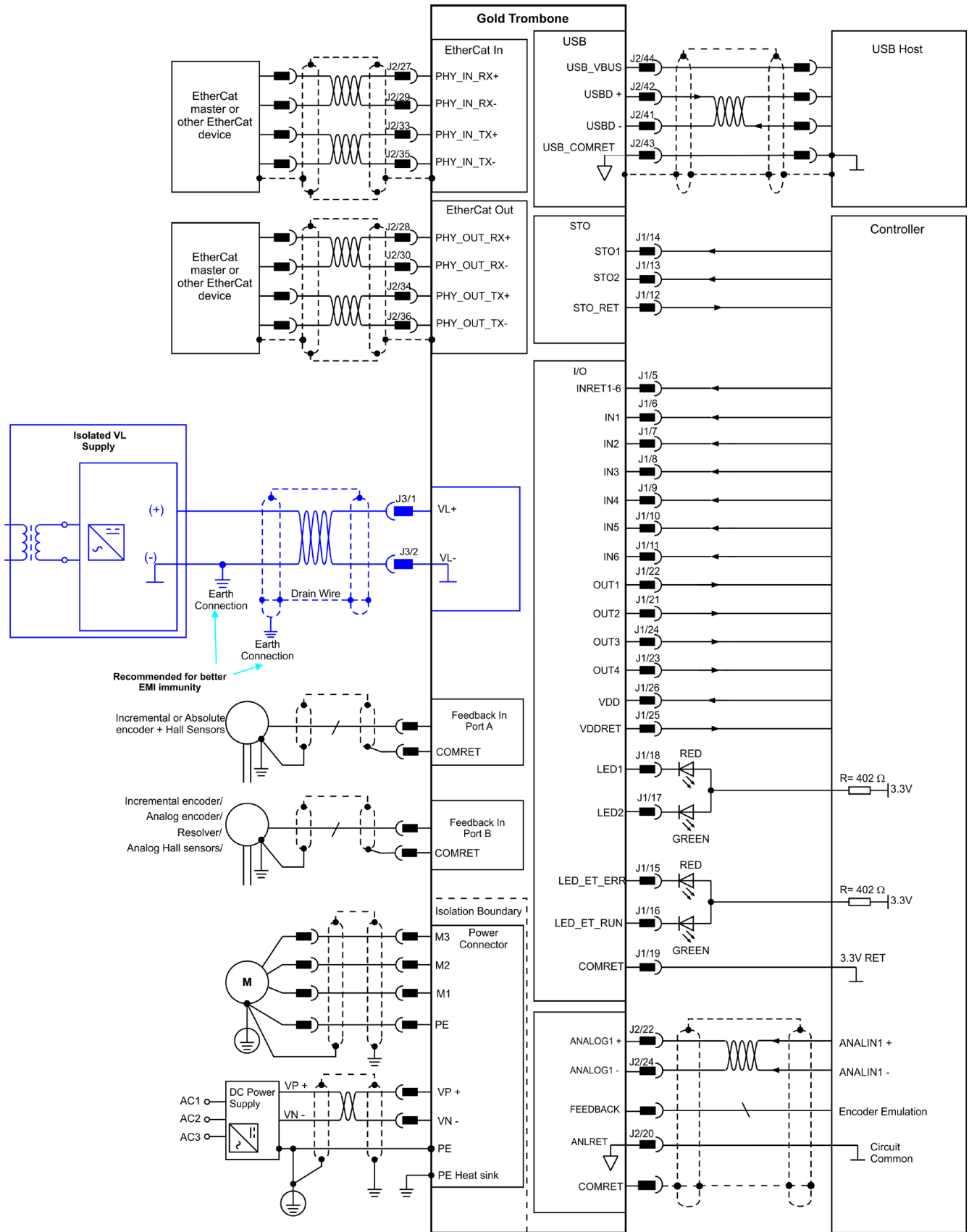

GTR0033F

Figure 3: Gold Trombone Connection Diagram for EtherCAT – with Backup Functionality (S or T Model Drive)

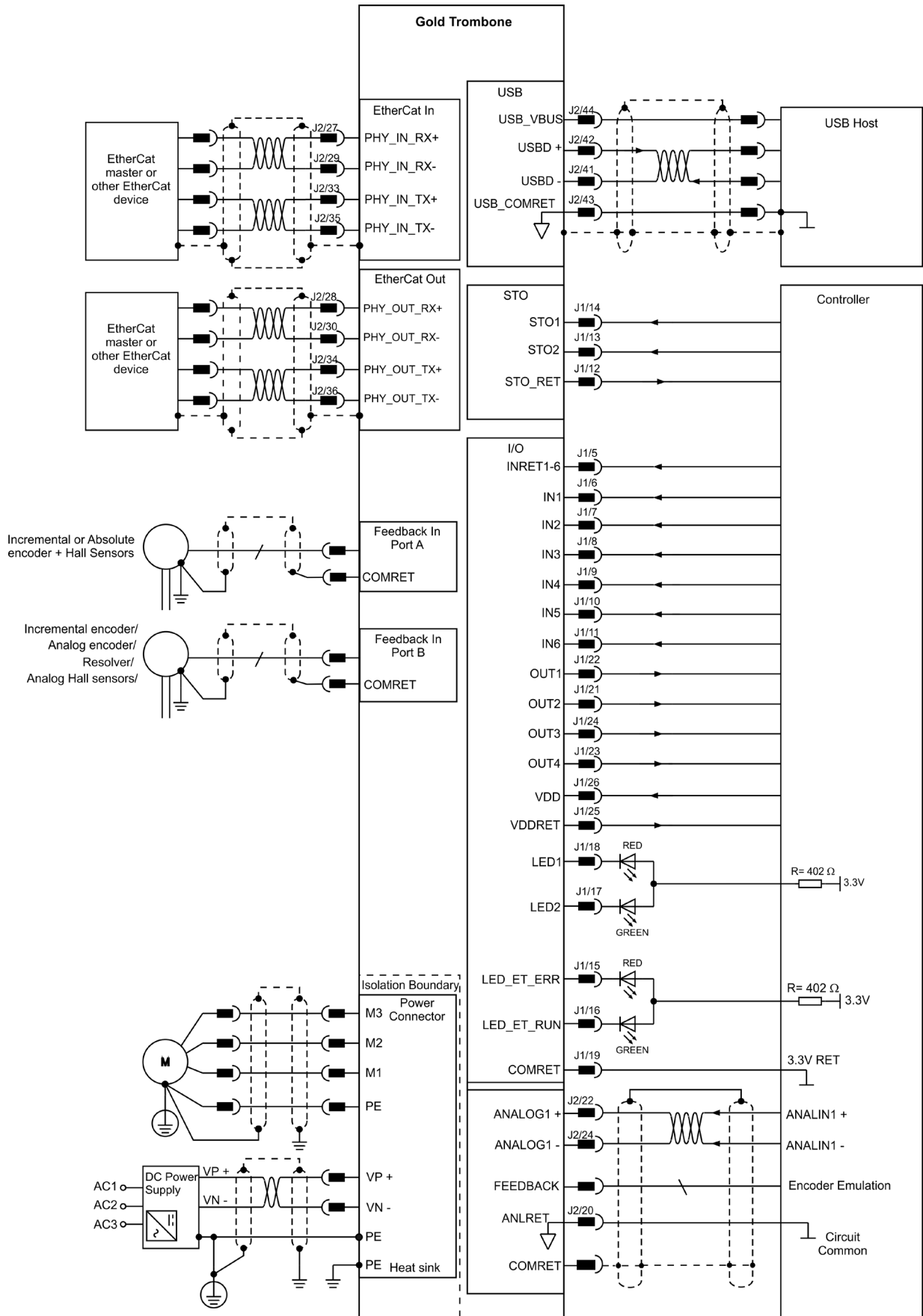

GTRO002F

Figure 4: Gold Trombone Connection Diagram for EtherCAT – 400 V without Backup Functions (0 or 1 Suffix)

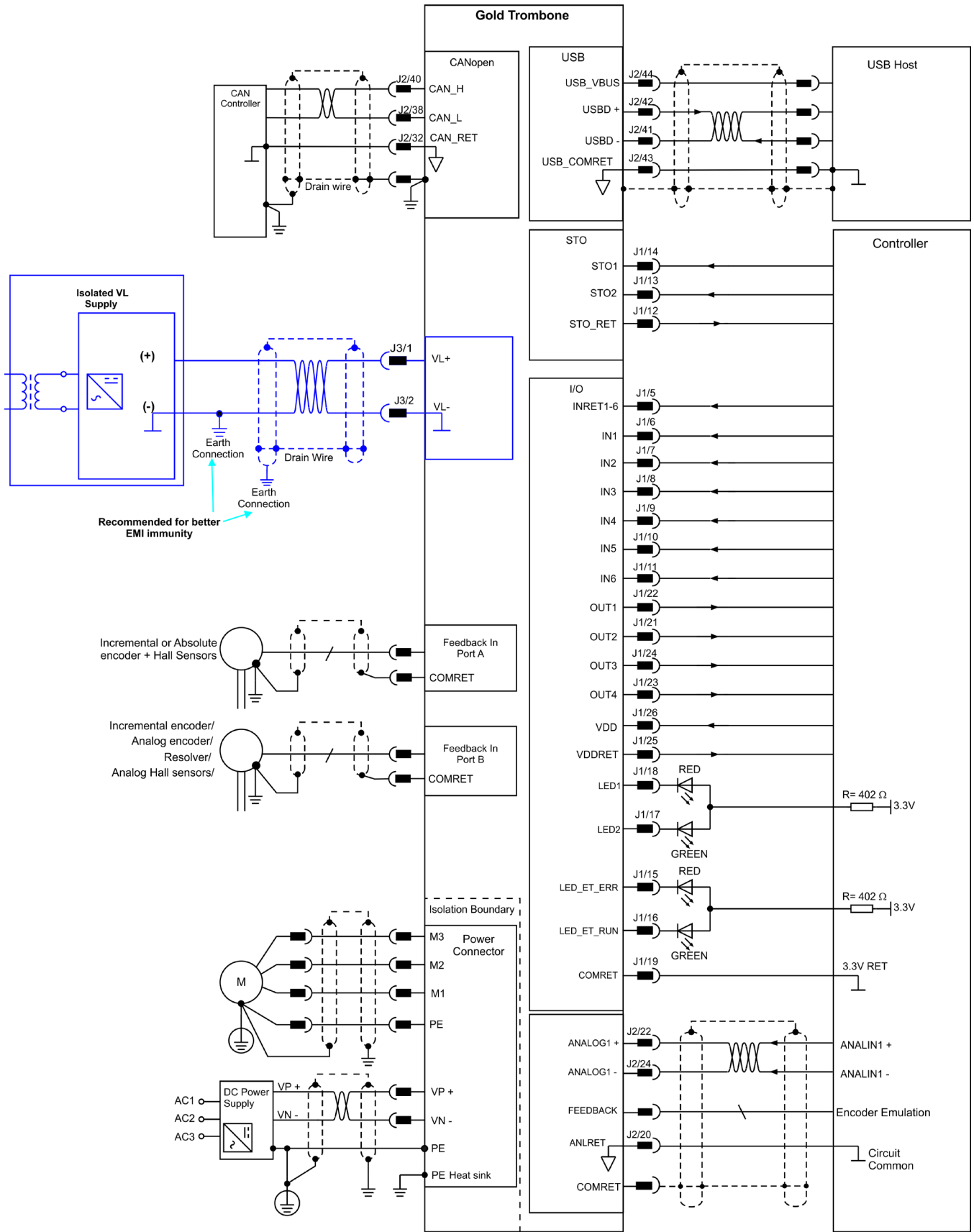

GTR0050C

Figure 5: Gold Trombone Connection Diagram for CAN – with Backup Functionality (S or T Model Drive)

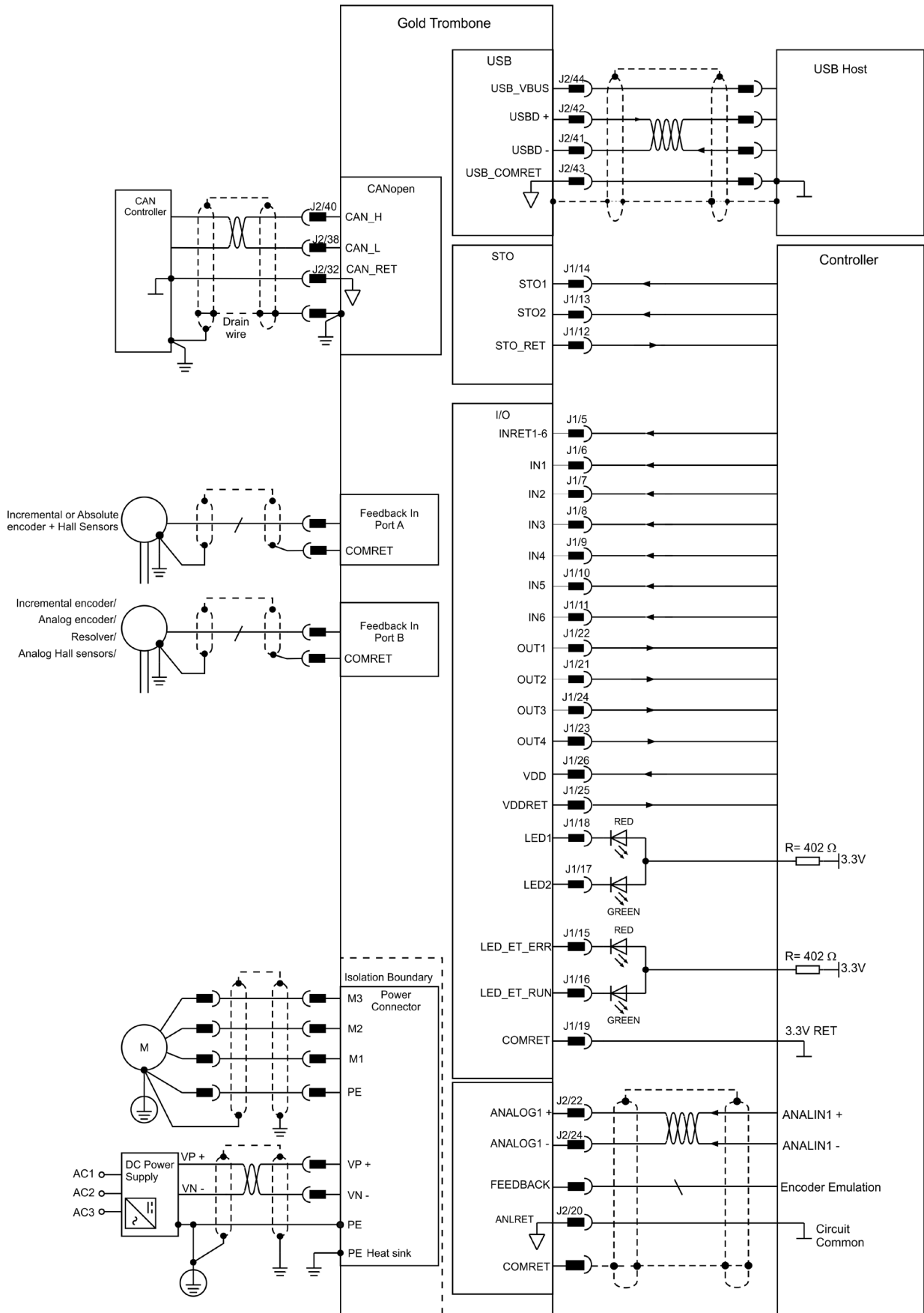

GTR0049C

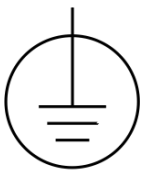

Figure 6: Gold Trombone Connection Diagram for CAN – 400 V without Backup Functions (0 or 1 Suffix)



Chapter 9: PCB Connections

9.1. Wiring legend

The following table legend describes the wiring symbols detailed in all installation guides. All the wiring diagrams show wiring for D-TYPE connectors.

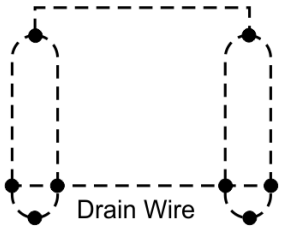
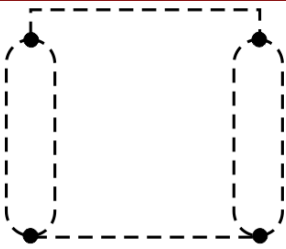
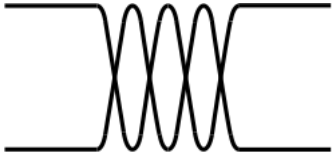
Wiring Symbol	Description
 GGEN_DTYPE101C-A	Earth connection (PE)
 GGEN_101D-B	Earth Connection
 GGEN_101D-C	Common at the Controller
 GGEN_101D-D	Shielded cable with drain wire. The drain wire is a non-insulated wire that is in direct contact with the braid (shielding). Shielded cable with drain wire significantly simplifies the wiring and earthing.
 GGEN_101D-E	Shielded cable braid only, without drain wire.
 GGEN_101D-F	Twisted-pair wires

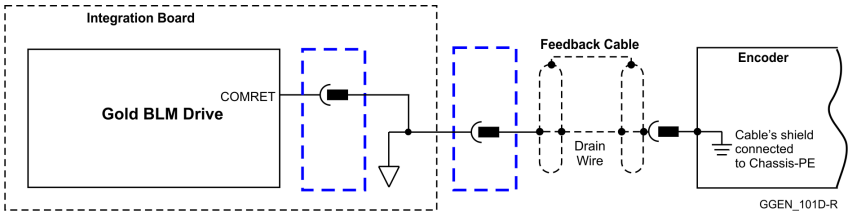

Wiring Symbol	Description
 <p>The diagram illustrates the wiring for encoder earthing. On the left, an 'Integration Board' contains a 'Gold BLM Drive' with a 'COMRET' terminal. This terminal is connected to a ground symbol. A 'Feedback Cable' connects the drive to an 'Encoder'. A 'Drain Wire' is also connected to ground. The encoder's shield is connected to 'Chassis-PE'. The diagram is labeled 'GGEN_101D-R'.</p>	<p>Encoder Earthing.</p> <p>The cable's shield is connected to the chassis (PE) in the connector.</p> <p>Earthing the Encoder and connecting the Earth (PE) to the drive COMRET is mandatory to insure reliable operation, high noise immunity and rejection of voltage common mode interferences.</p>



9.2. Connector Types

The Gold Trombone has 9 connectors.

Port	Pins	Type	Function
J1	2x13	1.27 mm pitch	Analog Input, Feedback
J2	2x24	0.41 mm sq	Communications
J3/1	1	2 mm pitch 0.51 mm sq	24 VDC Control supply input positive (Only in Trombones with the S or T suffix)
J3/2	1		24 VDC Control supply input return (Only in Trombones with the S or T suffix)
VP+	2	2.54 mm pitch	Positive DC power input
VN-	2	0.64 mm sq	Negative DC power input
PE	2		Protective earth
M1	2		Motor power output 1
M2	2		Motor power output 2
M3	2		Motor power output 3

Connector Location

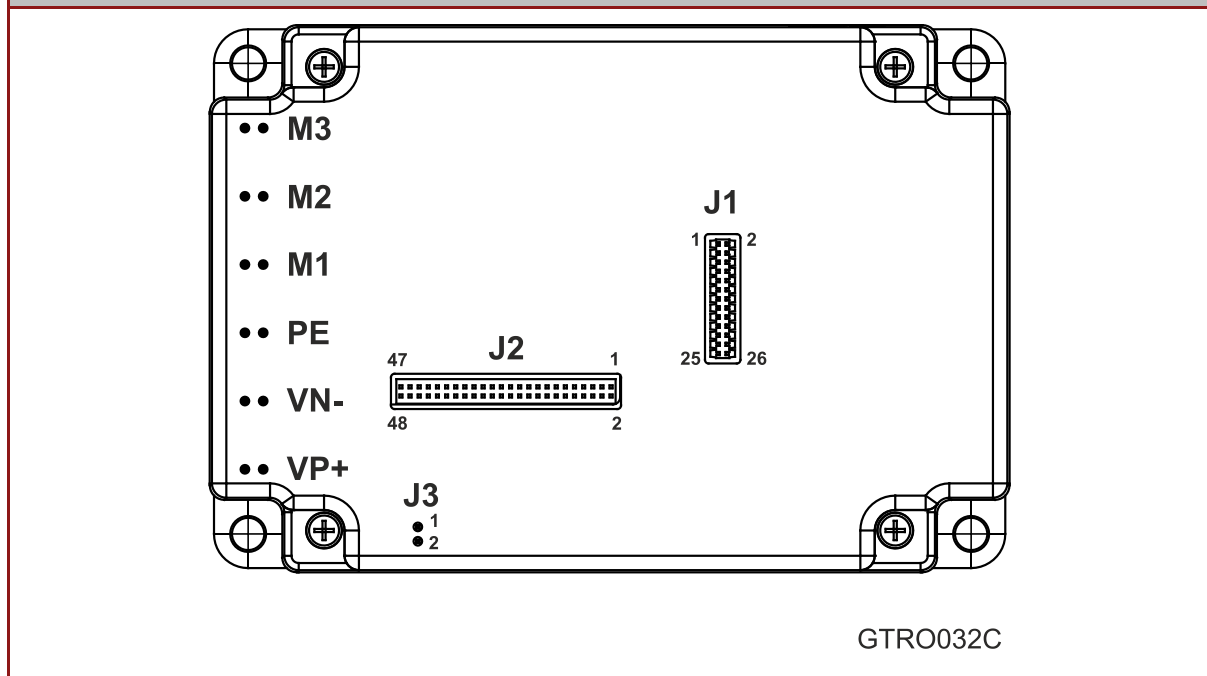

Table 1: Connector Types

9.3. Drive Status Indicator

For details of the Drive Status Indicator wiring, refer to the Chapter 7 in the MAN-G-Board Level Modules Hardware Manual.



9.4. Motor Power Connector Pinouts

For full details see Chapter 8 in the MAN-G-Board Level Modules Hardware Manual.

Pin	Function	Cable		Pin Positions
		Brushless Motor	Brushed DC Motor	
M3	Motor phase	Motor	Motor	
M2	Motor phase	Motor	Motor	
M1	Motor phase	Motor	N/C	
PE	Protective Earth	Motor	Motor	
Connector Type: 2 mm pitch 0.51 mm sq				

Table 2: Connector for Motor

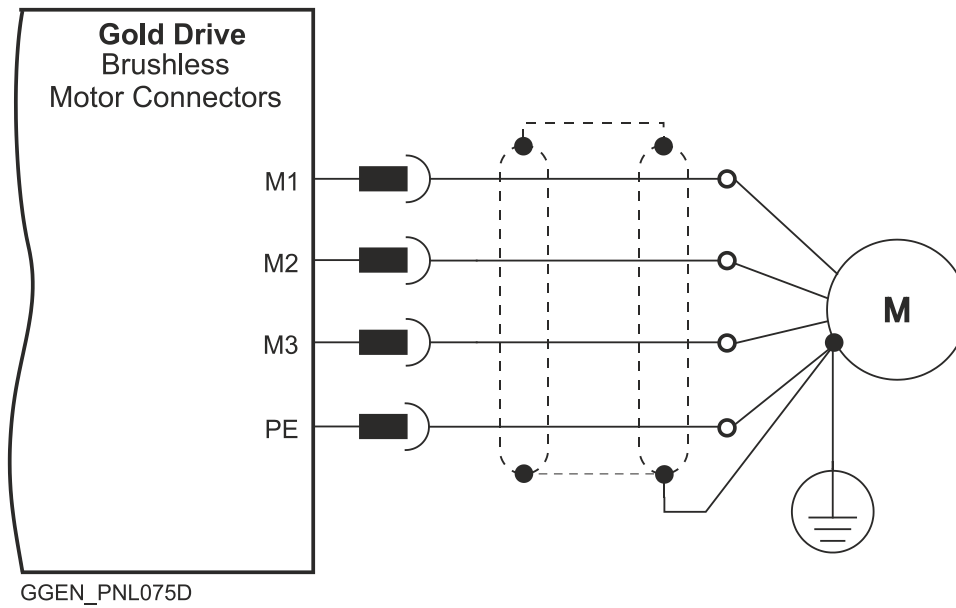

Figure 7: Brushless Motor Power Connection Diagram

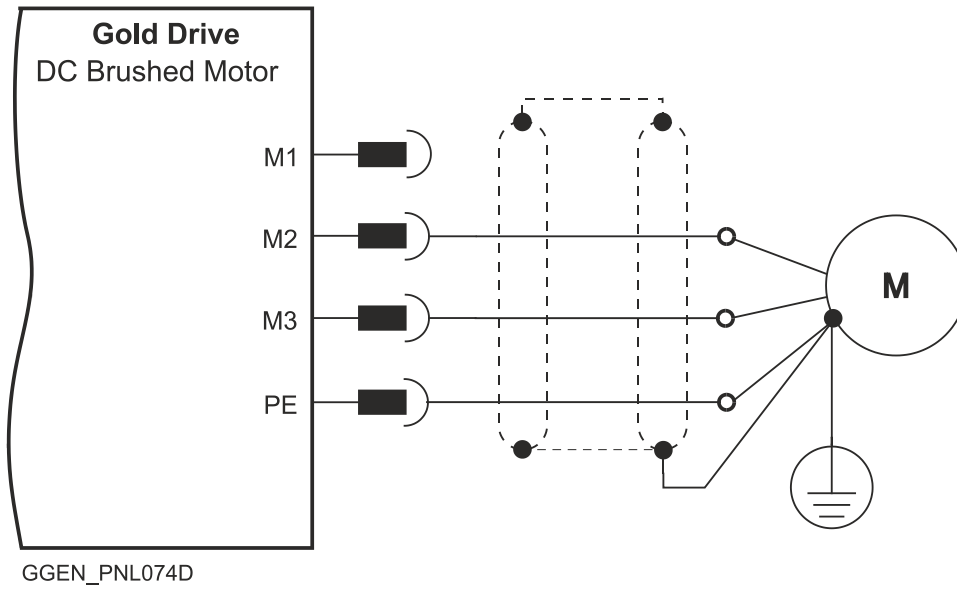

Figure 8: Brushed Motor Power Connection Diagram



9.5. Main Power and Control Connector

9.5.1. Main Power

There are multiple voltage ratings of the Gold Trombone (50 V to 780 V). Make sure to use the correct power supply according to the maximum operating voltage of the Gold Trombone.

Pin	Function	Cable	Pin Positions
PE	Protective Earth	Power and Motor	
VN-	DC Negative Power input	Power	
VP+	DC Positive Power input	Power	
Connector Type: 2 mm pitch 0.51 mm sq			

Table 3: Connector for Main Power

The DC power source for the Gold Trombone is delivered from a separated rectifying unit (supplied by the user). Elmo recommends using the Tambourine rectifier specifically designed for use with Elmo drives which offers a range of versatile options.

The following sections contain topology recommendations for implementing three-phase and single-phase supply chains.

The power stage of the Gold Trombone is fully isolated from the other sections of the Gold Trombone, such as the control supply and the heat-sink. This isolation allows the user to connect the common of the control section to the PE, a connection which significantly contributes to proper functionality, safety and EMI immunity, leading to better performance of the Gold Trombone.

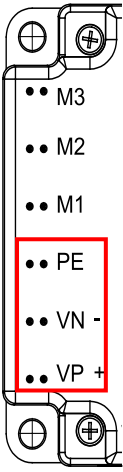
In addition, this isolation simplifies the requirements of the DC power supply that is used to power the DC bus of the Gold Trombone, by allowing it to operate with a non-isolated DC power source (a direct-to-mains connection) which eliminates the need for a bulky and expensive isolation transformer.

However, as well as operating from a non-isolated/direct-to-mains DC power supply, the Gold Trombone can also operate from an isolated power supply or batteries.

When rectifying an AC voltage source, the AC voltage level must be limited to 270 VAC so as not to exceed the maximum 390 VDC in the case of a 400 VDC drive, or 528 VAC so as not to exceed the maximum 747 VDC in the case of an 800 VDC drive.



9.5.1.1. Direct-to-Mains Power Source

This section relates to the configuration of the power supply and drive, which are connected directly to the mains.

To connect the non-isolated DC power supply:

1. For best immunity, it is highly recommended to use twisted cables for the DC power supply cable. A 3-wire shielded cable should be used. The gauge is determined by the actual current consumption of the motor.
2. Connect both ends of the cable shield to the closest PE connections.
3. Tie one end to the power supply's PE terminal, and tie the other end either to the PE pins of the module/PE terminal of the integration board, or attach it to one of the four mounting screws of the drive's heat-sink.

9.5.1.1.a Three-Phase Direct-to-Mains Connection Topology

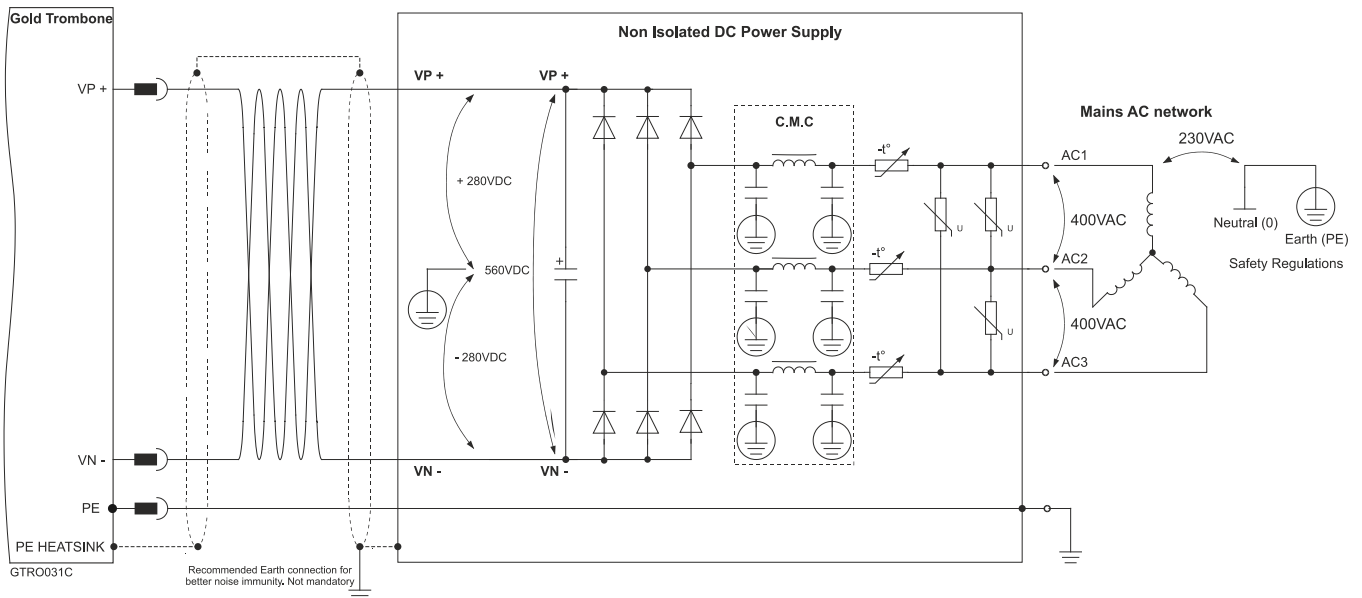

Figure 9: Non-Isolated Three-Phase Connection Topology



Caution:

- Do not connect VN- to PE. In a direct-to-mains connection the VN- must **not be connected to the PE**, as this will cause irreparable damage to the system.
- Take care and note that in a direct-to-mains connection the Neutral point is *not* the most negative voltage level. It is the mid-point level of the rectified DC bus.



9.5.1.1.b Single-Phase Direct-to-Mains Connection Topology

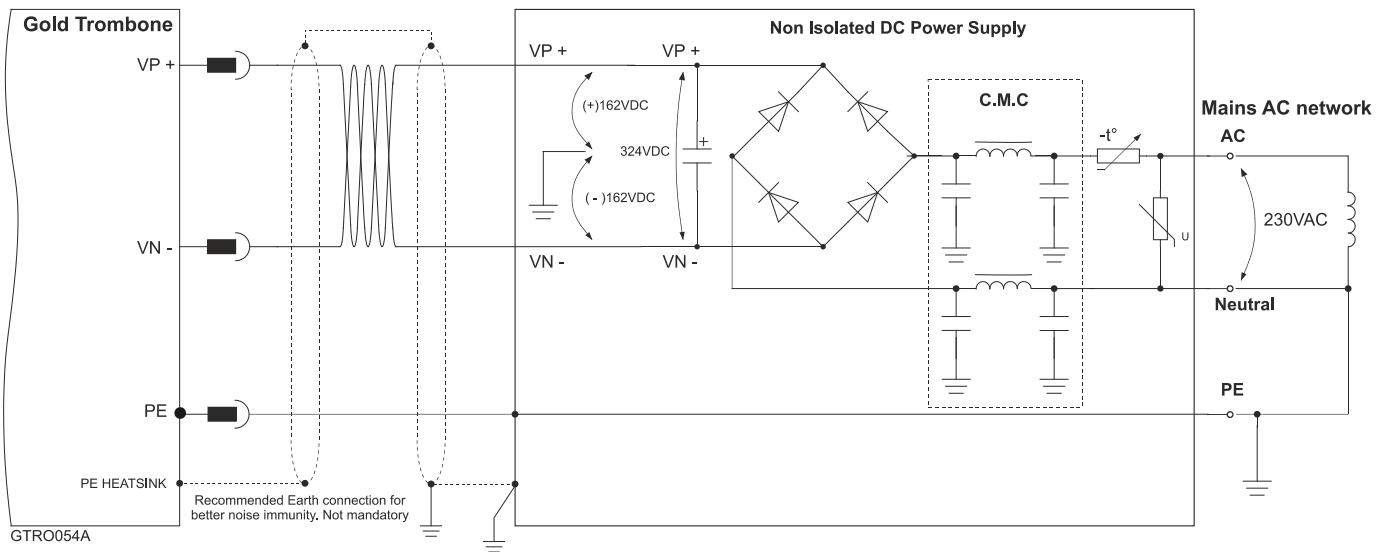

Figure 10: Non-Isolated Single-Phase Connection Topology

The Power Supply is connected directly to the mains AC line.



Warning:

- Do not connect VN- to PE. In a direct-to-mains connection the VN- must **not be connected to the PE**, as this will cause irreparable damage to the system.
- Take care and note that in a direct-to-mains connection the Neutral point is *not* the most negative voltage level. It is the mid-point level of the rectified DC bus.



9.5.1.1.c Multiple Connections Topology

In a multi-axis application it is likely that a single power supply can feed several drives in parallel. This topology is efficient and cost saving, by reducing the number of power supplies and the amount of wiring. Most importantly it utilizes an energy sharing environment among all the drives that share the same DC bus network.



The power supply is connected directly to the mains AC line, and it feeds more than one drive.

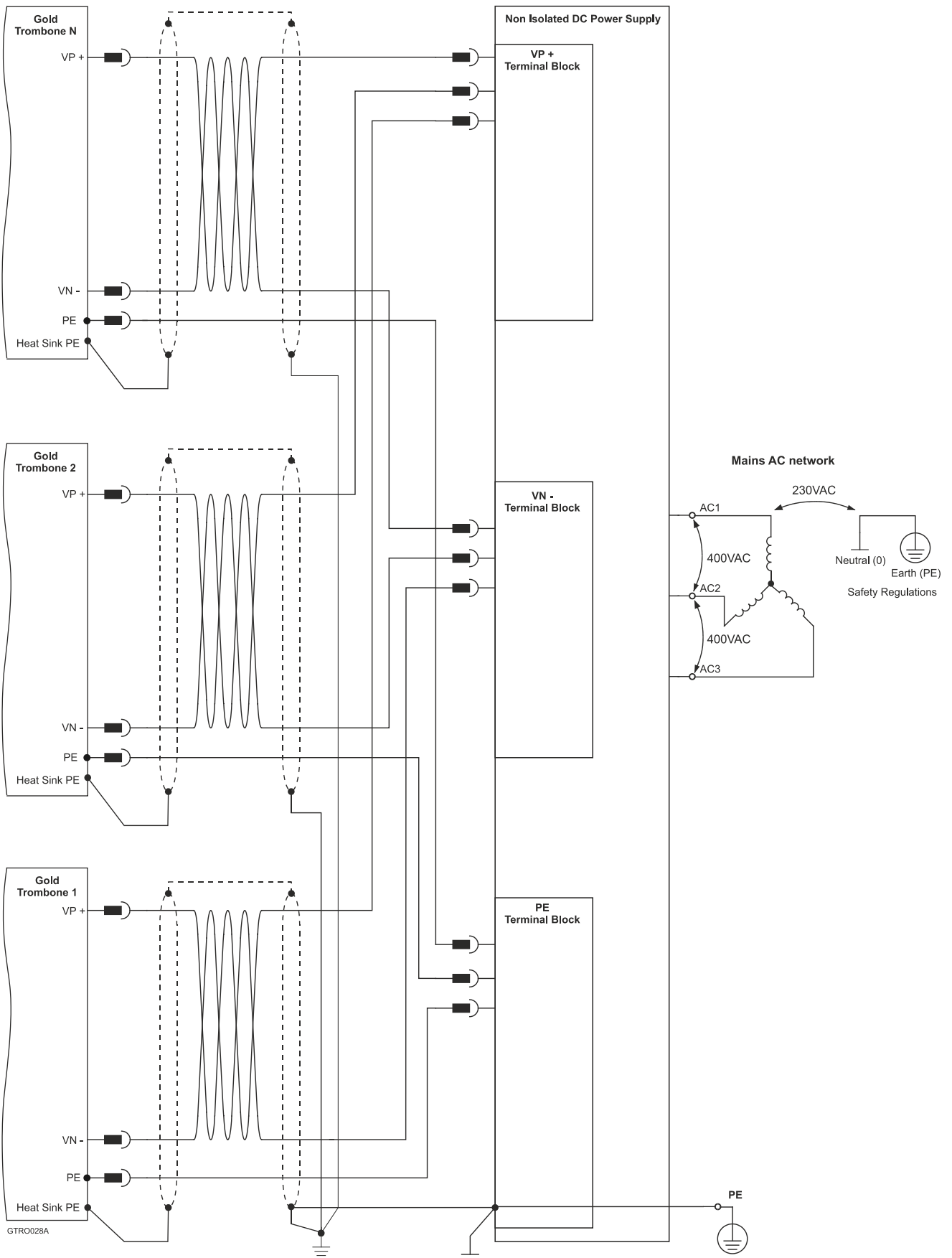

Figure 11: Non-Isolated Three-Phase Multiple Connection Topology



9.5.1.2. Battery Power Supply

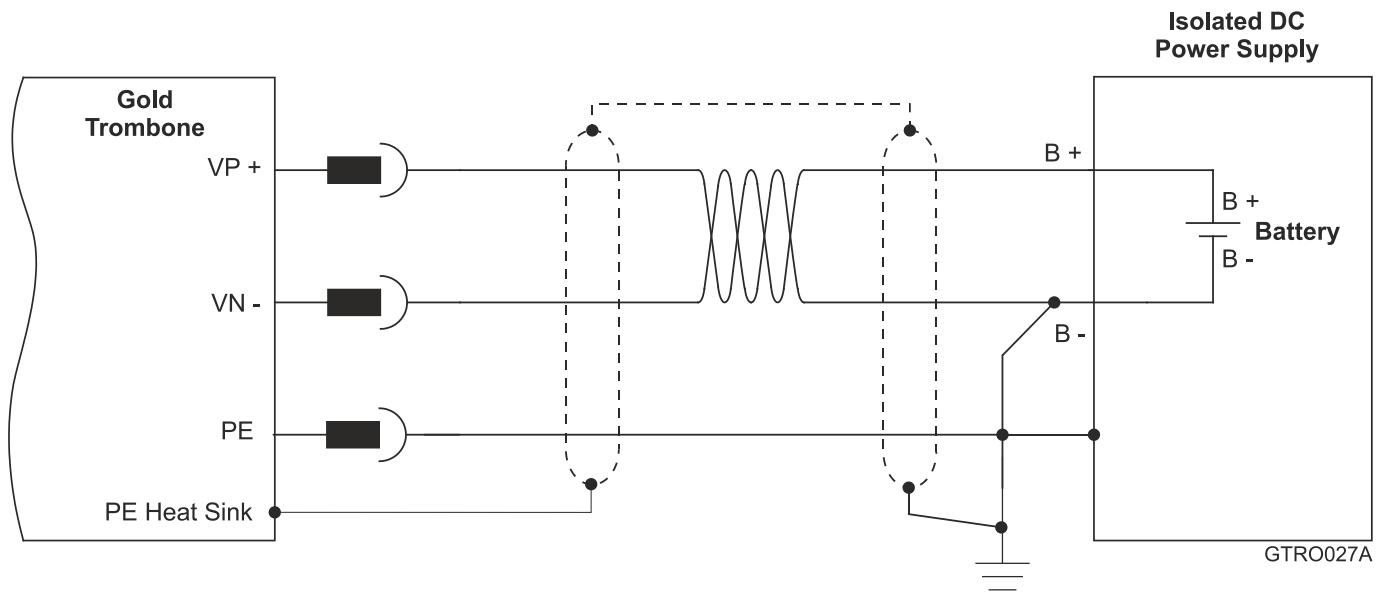

Figure 12: Battery Connection Topology



Caution: When using batteries, it is recommended to connect the negative pole to the PE.

When doing so, the charger of the battery **must** be isolated from the mains by an isolation transformer.



9.5.2. +24 V Control Supply (J3)

Pin (J3)	Function	Pin Positions
1	+24 V Control Supply Input Positive	
2	24 V RET Control Supply Input Return	

Table 4: 24 VDC Control Supply Pins and Polarity

In drives that have a 0 or 1 suffix (only for 400V models), only one power supply is required for the main and control power, *with no need for a control supply voltage to supply the drive's logic section.*

If separation between the main DC power source and a control supply is required, then an S or T-model Gold Trombone should be used, with an external 24 VDC isolated control supply connected to it.

Note that the S or T-model Gold Trombone always requires an external 24 VDC power supply.

Connect the control 24 VDC power supply as described below.

To connect your integration board to the control supply:

1. Use a 24 AWG twisted pair shielded cable. The shield should have copper braid.
2. The source of the 24 VDC control supply must be isolated with an isolation transformer.
3. For safety and EMI reasons, connect the return of the 24 VDC backup supply to the closest ground (PE).
4. Connect the cable shield to the closest ground (PE) near the power source.
5. Before applying power, first verify that the polarity of the connection is correct.



9.6. Connector J2 - Feedback, Analog Inputs, RS-232, USB, EtherCAT, Ethernet, and CAN

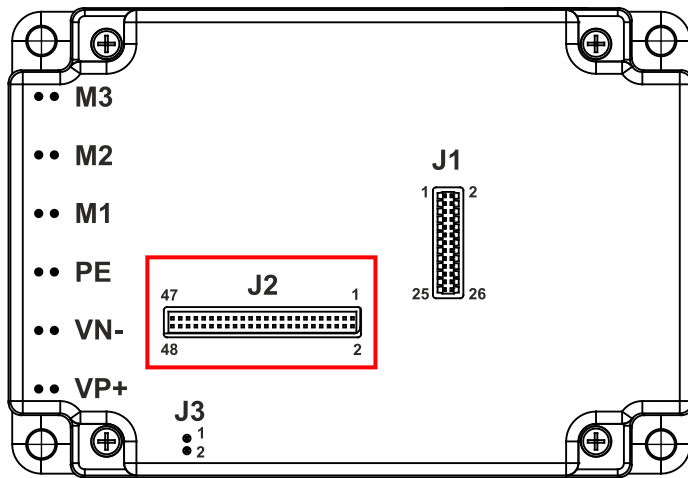

GTRO032C

Feedback A/B/C, Digital Halls – see Chapter 10: Feedbacks in the MAN-G-Board Level Modules Hardware Manual.

Analog Inputs - For full details on Analog Inputs, see Chapter 12 in the MAN-G-Board Level Modules Hardware Manual.

RS-232 – For full details on RS-232 see section 14.4 in the MAN-G-Board Level Modules Hardware Manual.

USB 2.0 – For full details on USB see section 14.1 in the MAN-G-Board Level Modules Hardware Manual.

EtherCAT/Ethernet – For full details on EtherCAT/Ethernet see section 14.2. in the MAN-G-Board Level Modules Hardware Manual.

CAN – For full details on CAN see section 14.3 in the MAN-G-Board Level Modules Hardware Manual.

Connector Type: 1.27 mm pitch 0.41 mm sq

Note regarding the EtherCAT and CAN communication options:

The J2 Connector exports all supported communication links. However, note that CAN and EtherCAT are not available in the same version of the Gold Trombone and are thus not operational simultaneously. See the part number diagram in Section 5.1 above for the different Gold Trombone configurations.

Pin (J2)	Signal	Function
1	PortA_ENC_A+ /ABS_CLK+	Port A- channel A/ Absolute encoder clock+
2	PortC_ENCO_A-	Port C- channel A complement output
3	PortA_ENC_A-/ABS_CLK-	Port A- channel A complement / Absolute encoder clock-
4	PortC_ENCO_A+	Port C- channel A output
5	PortA_ENC_B+/ABS_DATA+	Port A - channel B/ Absolute encoder Data+
6	PortC_ENCO_B-	Port C - channel B complement output
7	PortA_ENC_B-/ABS_DATA-	Port A - channel B complement / Absolute encoder Data-



Pin (J2)	Signal	Function
8	PortC_ENCO_B+	Port C - channel B output
9	PortA_ENC_INDEX+	Port A – index
10	PortC_ENCO_INDEX-	Port C - index complement output
11	PortA_ENC_INDEX-	Port A - index complement
12	PortC_ENCO_INDEX+	Port C - index output
13	PortB_ENC_A+/SIN+	Port B - channel A
14	HC	Hall sensor C input
15	PortB_ENC_A-/SIN-	Port B - channel A complement
16	HB	Hall sensor B input
17	PortB_ENC_B+/COS+	Port B - channel B
18	HA	Hall sensor A input
19	PortB_ENC_B-/COS-	Port B - channel B complement
20	ANLRET	Analog return
21	PortB_ENC_INDEX+/ANALOG_I+	Port B – index+/ Analog_Index+
	RESOLVER_OUT+	Vref complement f= 1/TS, 50 mA Maximum
22	ANALOG1+	Analog input 2
23	PortB_ENC_INDEX-/ANALOG_I-	Port B – index -/ Analog_Index-
	RESOLVER_OUT-	Vref complement f= 1/TS, 50 mA Maximum
24	ANALOG1-	Analog input 1 complement
25	COMRET	Common return
26	+3.3V	3.3 V supply voltage for EtherCAT LEDs
27	PHY_IN_RX+	EtherCAT In receive
28	EtherCAT: PHY_OUT_RX+	EtherCAT Out receive
	CAN: Reserved	Reserved
29	PHY_IN_RX-	EtherCAT In receive complement
30	EtherCAT: PHY_OUT_RX-	EtherCAT Out receive complement
31	COMRET	Common return
32	COMRET	Common return
33	PHY_IN_TX+	EtherCAT In transmit



Pin (J2)	Signal	Function
34	EtherCAT: PHY_OUT_TX+	EtherCAT Out transmit
	CAN: Reserved	Reserved
35	PHY_IN_TX-	EtherCAT In transmit complement
36	EtherCAT: PHY_OUT_TX-	EtherCAT Out transmit complement
37	PHY_IN_LINK_ACT	EtherCAT In active LED
38	EtherCAT: PHY_OUT_LINK_ACT	EtherCAT Out active LED
	CAN: CAN_L	CAN_L bus line (dominant low)
39	PHY_IN_SPEED	EtherCAT In speed LED
40	EtherCAT: PHY_OUT_SPEED	EtherCAT Out speed LED
	CAN: CAN_H	CAN_H bus line (dominant high)
41	USBD-	USB data complement
42	USBD+	USB data
43	COMRET	Common return
44	USB_VBUS	USB VBUS 5V
45	RS232_RX /SB_OUT	There are two options for this pin: Option 1: RS232 receive (default) Option 2: Serial Bus output for extended I/O (refer to the MAN-G-Board Level Modules Hardware Manual)
46	COMRET	Common return
47	Not in use	Keep unconnected. The +5.5 V originates from J1/2 instead.
48	RS232_TX /SB_IN	There are two options for this pin: Option 1: RS232 transmit (Default) Option 2: Serial Bus IN for extended I/O (refer to the MAN-G-Board Level Modules Hardware Manual)

Table 5: Connector J2 – Feedback and Analog Input



9.6.1. Feedback Port A

Port A supports the following sensor inputs:

- Digital Hall sensors
- Incremental encoder or absolute serial encoder, depending on the specific model
- Differential pulse-width modulation (PWM) signal input can be connected to port A
- Differential Pulse & Direction signal inputs can be connected to port A

9.6.1.1. Incremental Encoder

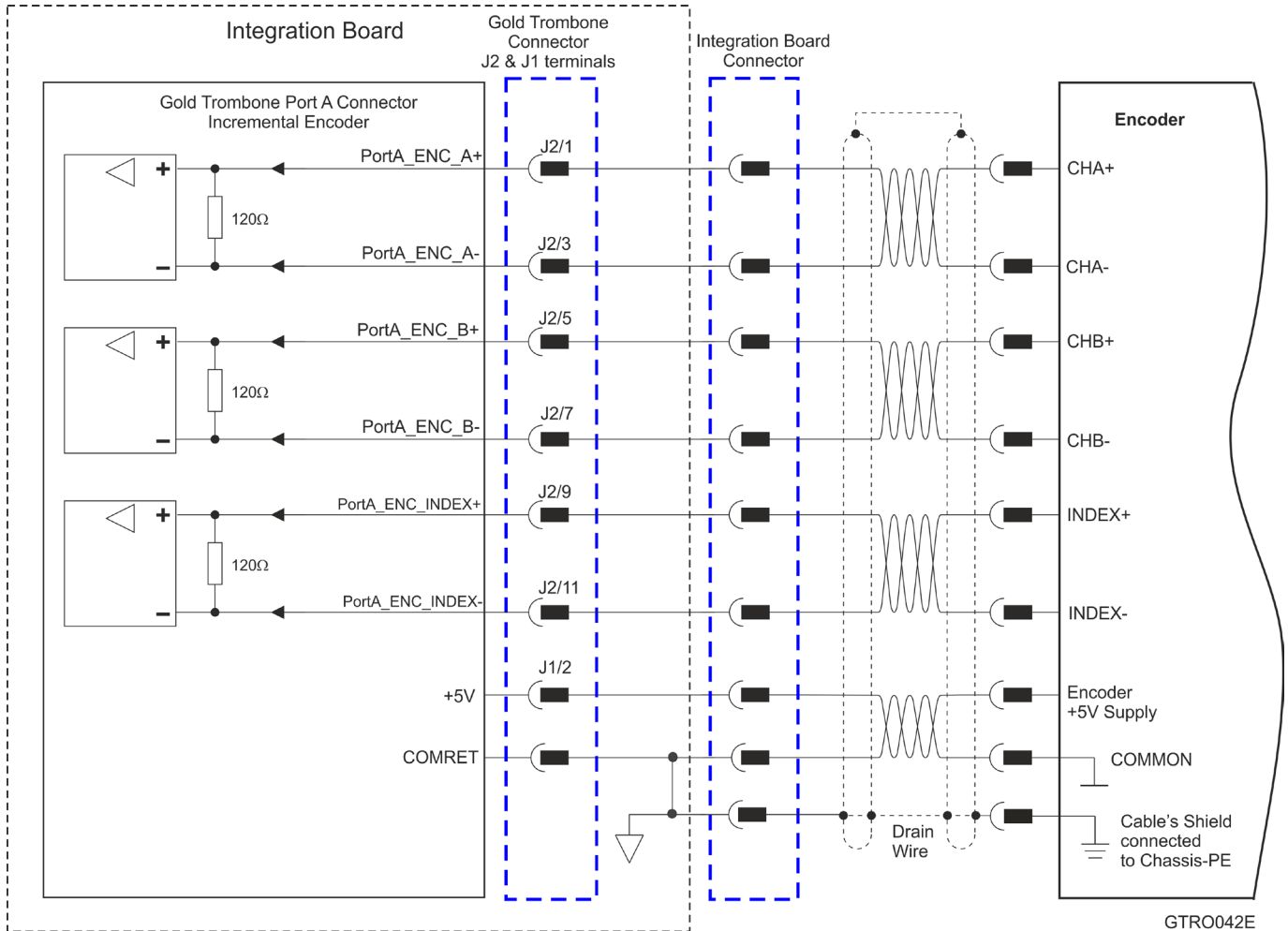
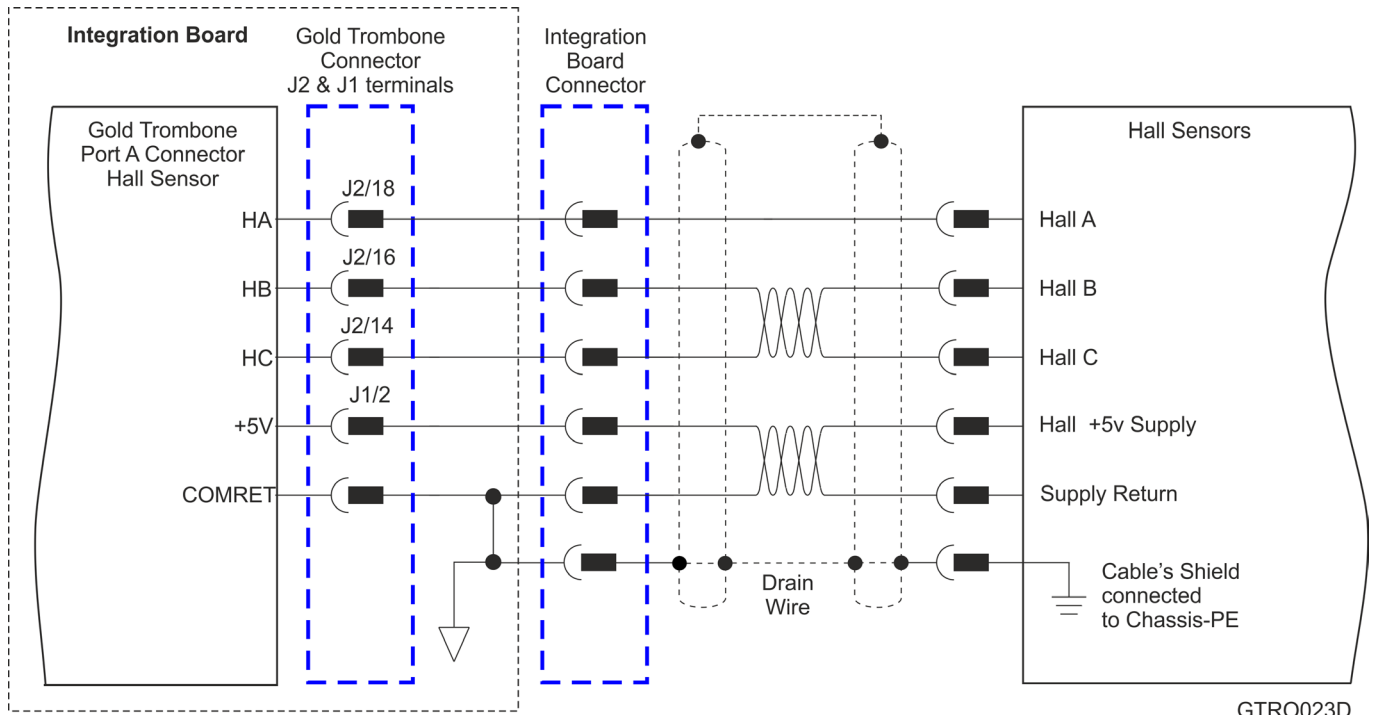

Figure 14: Port A Incremental Encoder Input – Recommended Connection Diagram



9.6.1.2. Hall Sensors



GTRO023D

Figure 15: Hall Sensors Connection Diagram



9.6.1.3. Absolute Serial Encoder

The following Absolute Encoder are supported:

- Endat 2.2
- Biss C and Biss B
- Panasonic
- Tamagawa
- SSI
- Sanyo Danki
- Hiperface

The following is the diagram connection of the Endat, Biss, SSI:

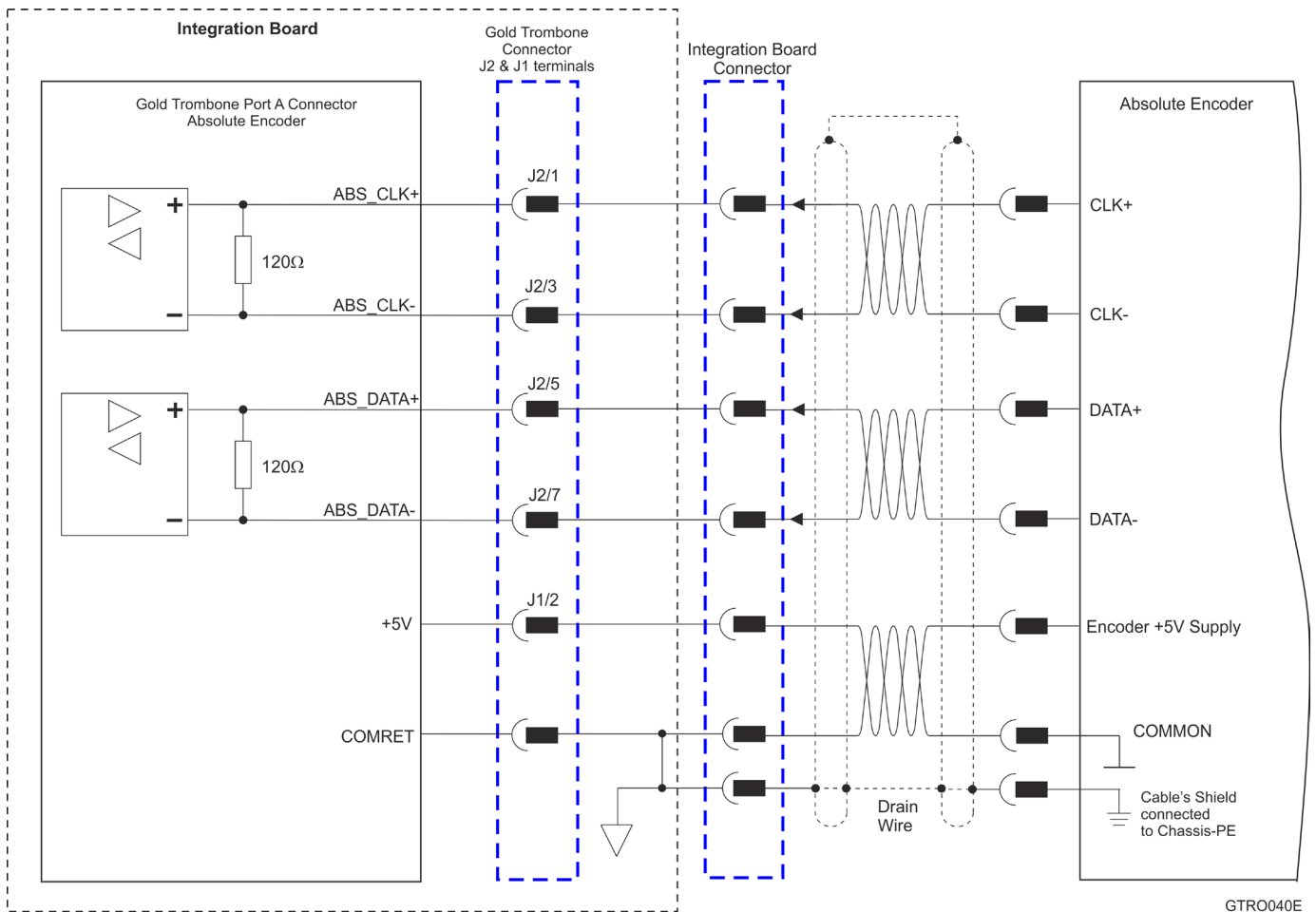

GTRO040E

Figure 16: Absolute Serial Encoder – Recommended Connection Diagram for Endat, Biss, SSI



The following is the diagram connection of the Panasonic, Tamgawai, Sanyo-Danki:

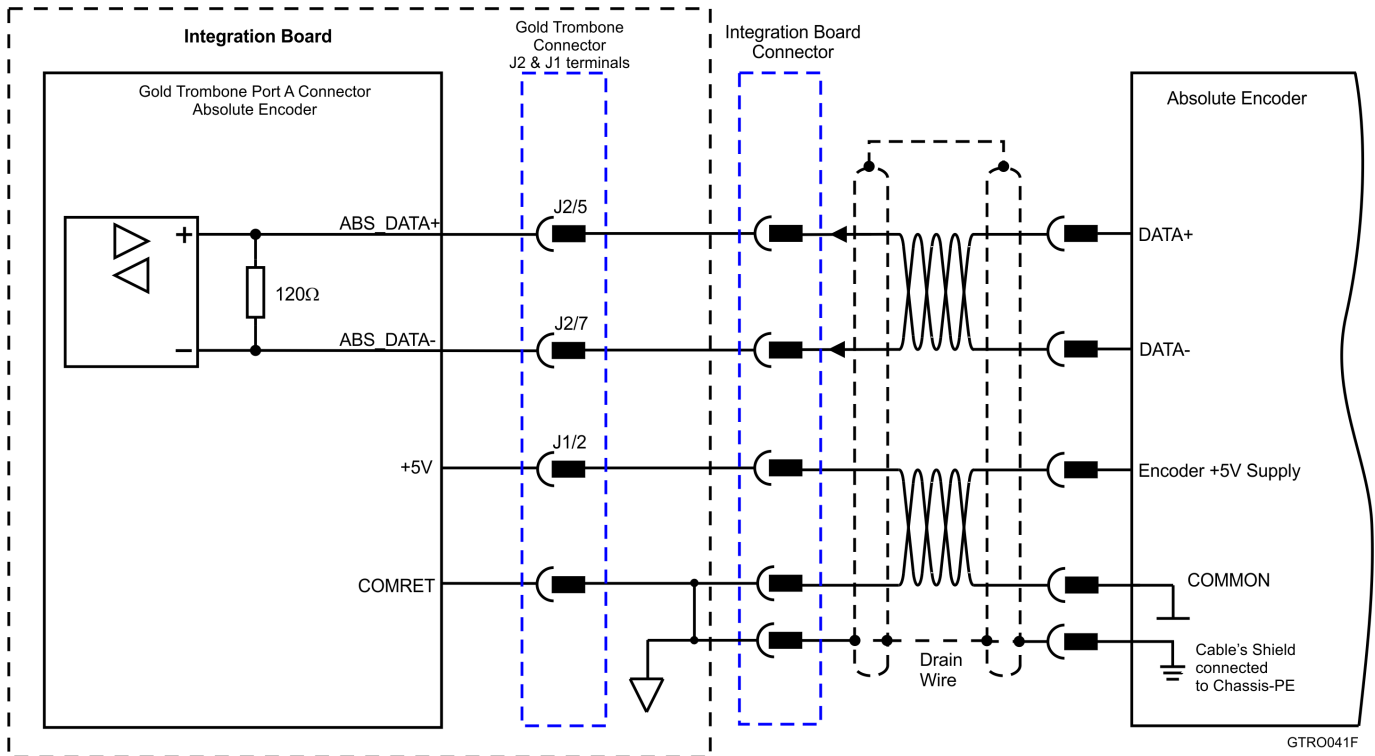

Figure 17: Absolute Serial Encoder – Recommended Connection Diagram for Panasonic, Tamgawai, Sanyo-Danki



9.6.1.4. Hiperface

The following figure describes the connection diagram.

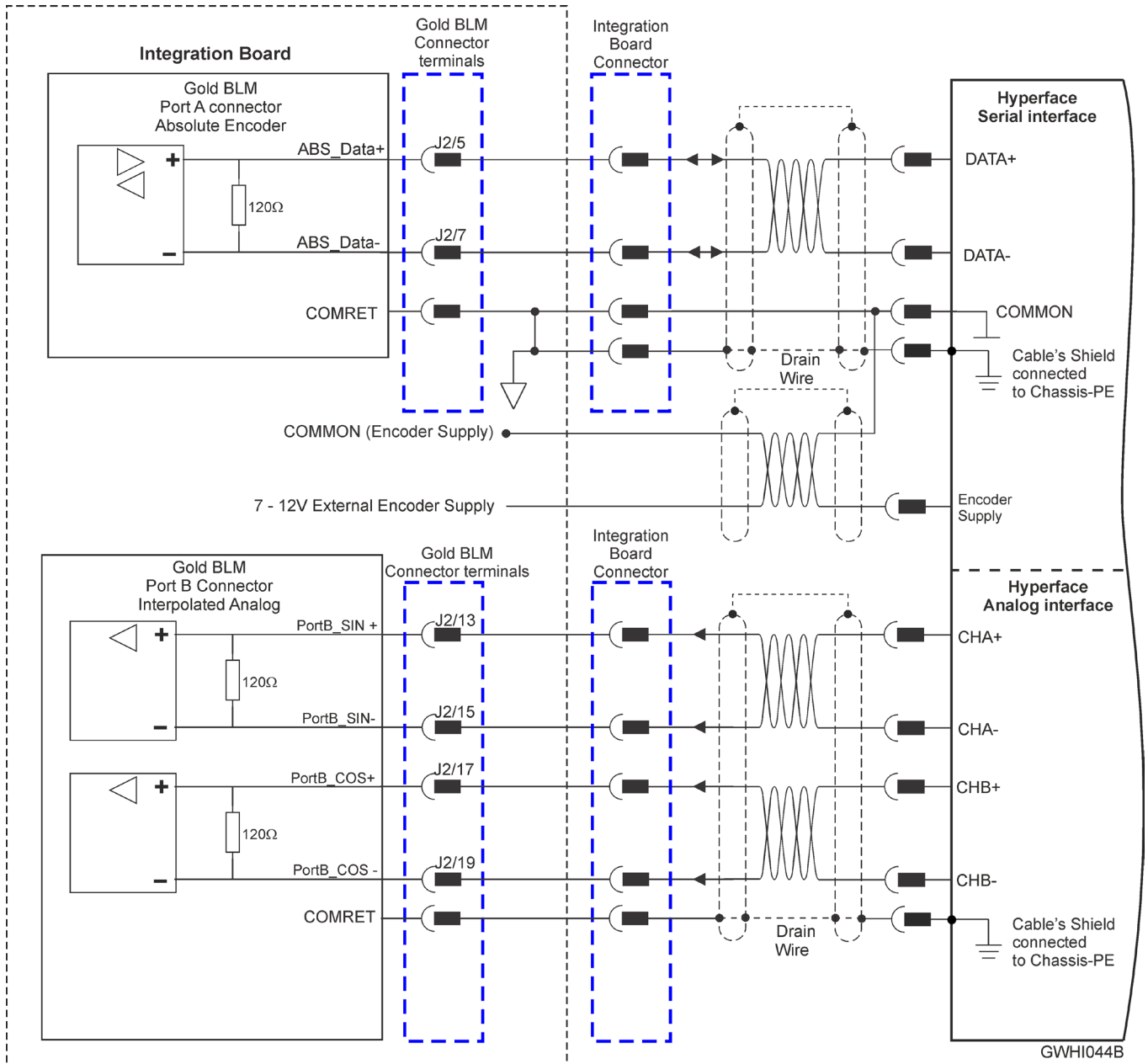

Figure 18: Absolute Serial Encoder – Recommended Connection Diagram for Stegmann Hiperface

Note: When the Hiperface protocol is used the RS232 is not available



9.6.2. Feedback Port B

Port B supports any of the following sensors:

- Incremental encoder, interpolated analog encoder or analog Hall sensors

Or

- Resolver (separate hardware option)

Differential PWM signal input can be connected to port B

Differential Pulse & Direction signal inputs can be connected to port B

9.6.2.1. Incremental Encoder

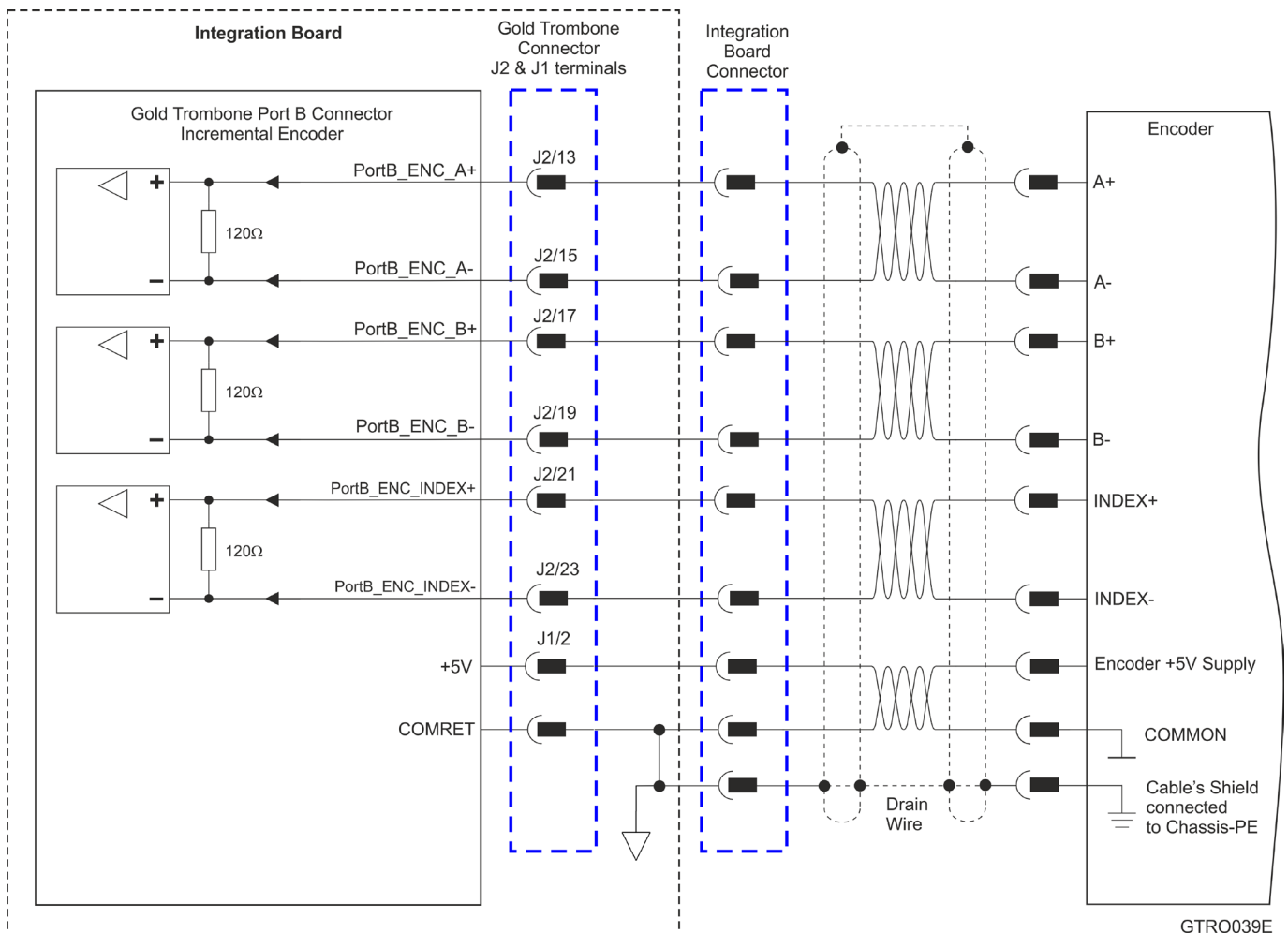

Figure 19: Port B Incremental Encoder Input – Recommended Connection Diagram



9.6.2.2. Interpolated Analog (Sine/Cosine) Encoder

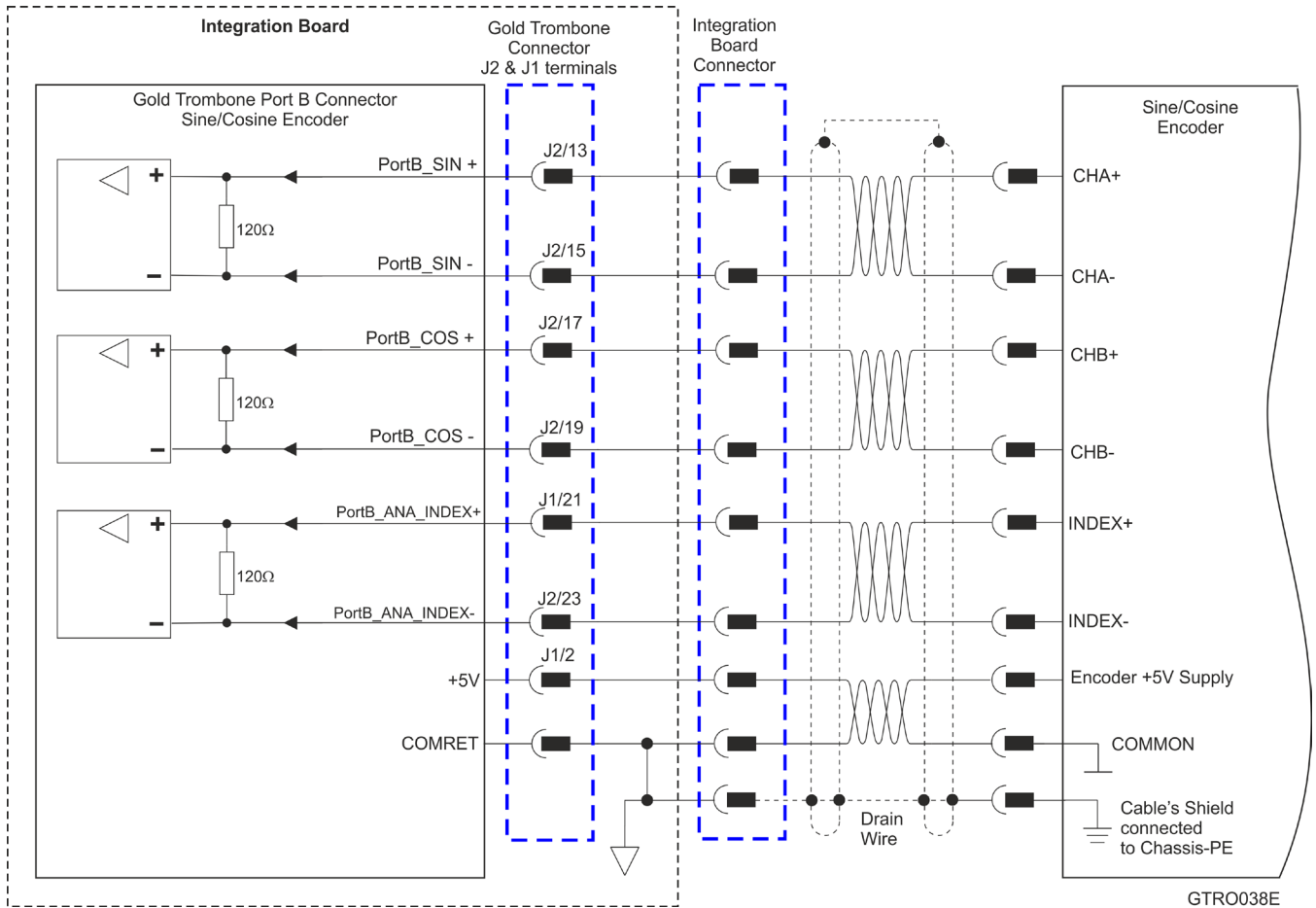

Figure 20: Port B - Interpolated Analog Encoder Connection Diagram



9.6.2.3. Resolver

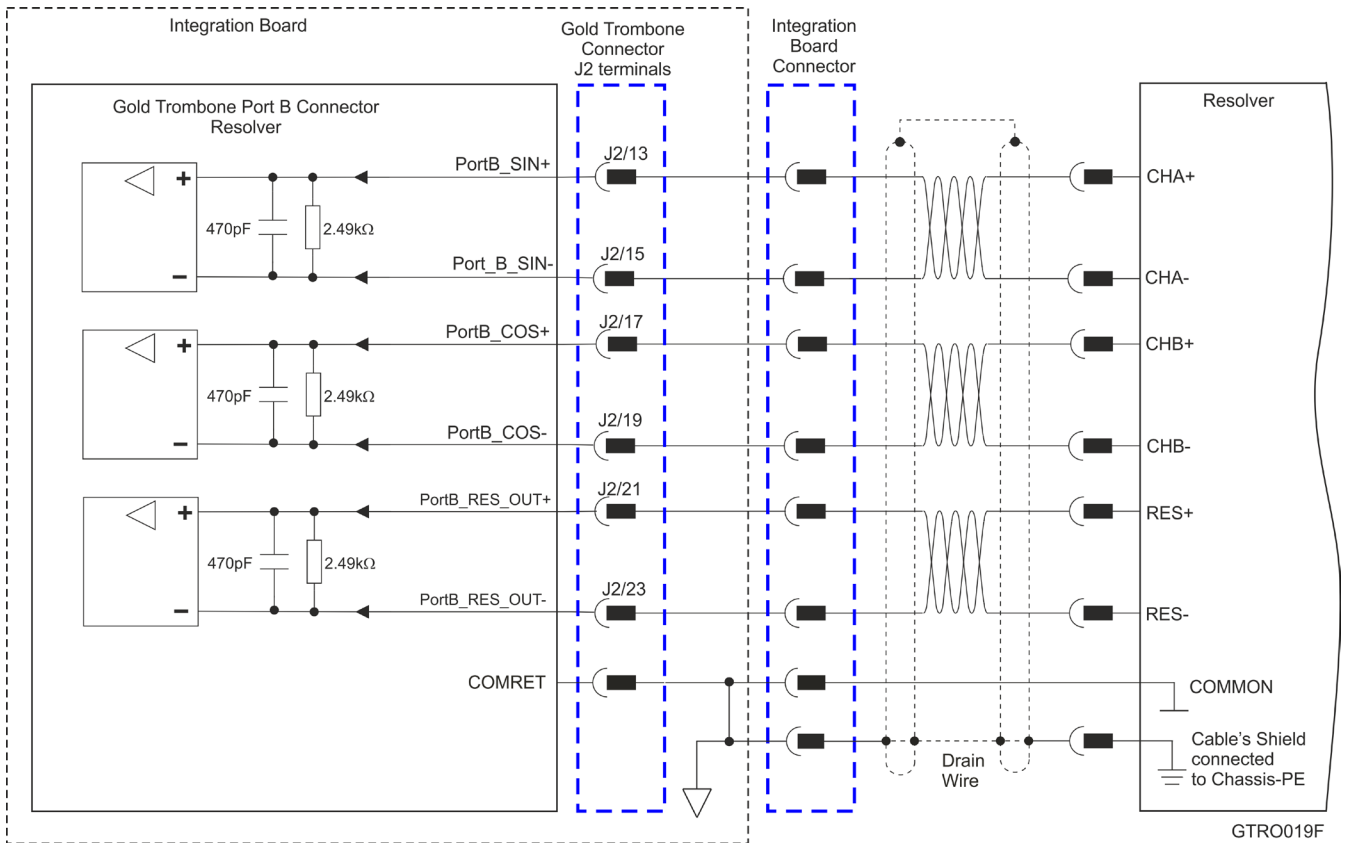

Figure 21: Port B – Resolver Connection Diagram

GTR0019F



9.6.3. Port C – Emulated Encoder Output

Port C provides emulated encoder output derived from port A or port B feedback inputs, or from internal variables.

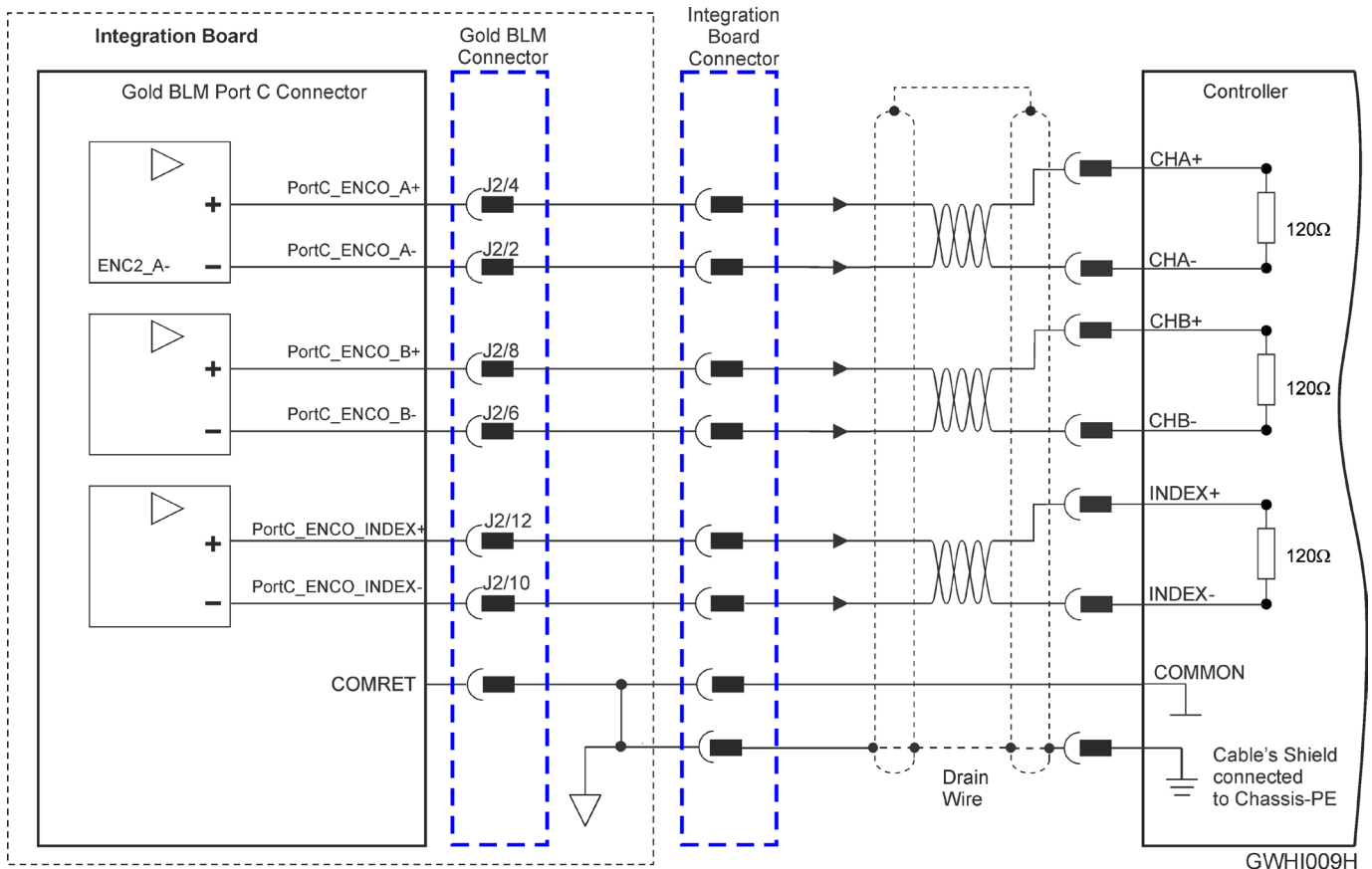

Figure 22: Emulated Encoder Differential Output – Recommended Connection Diagram



9.6.4. Analog Inputs

There are two possible types of Analog Inputs in the Gold Trombone:

- Analog Input 1 – Differential ± 10 V using Connector J2 in the Gold Trombone
- Analog Input 2 – Single ended using Connector J1 in the Gold Trombone

9.6.4.1. Analog Input 1

The following circuit (Figure 23) describes the internal interface of the Analog input.

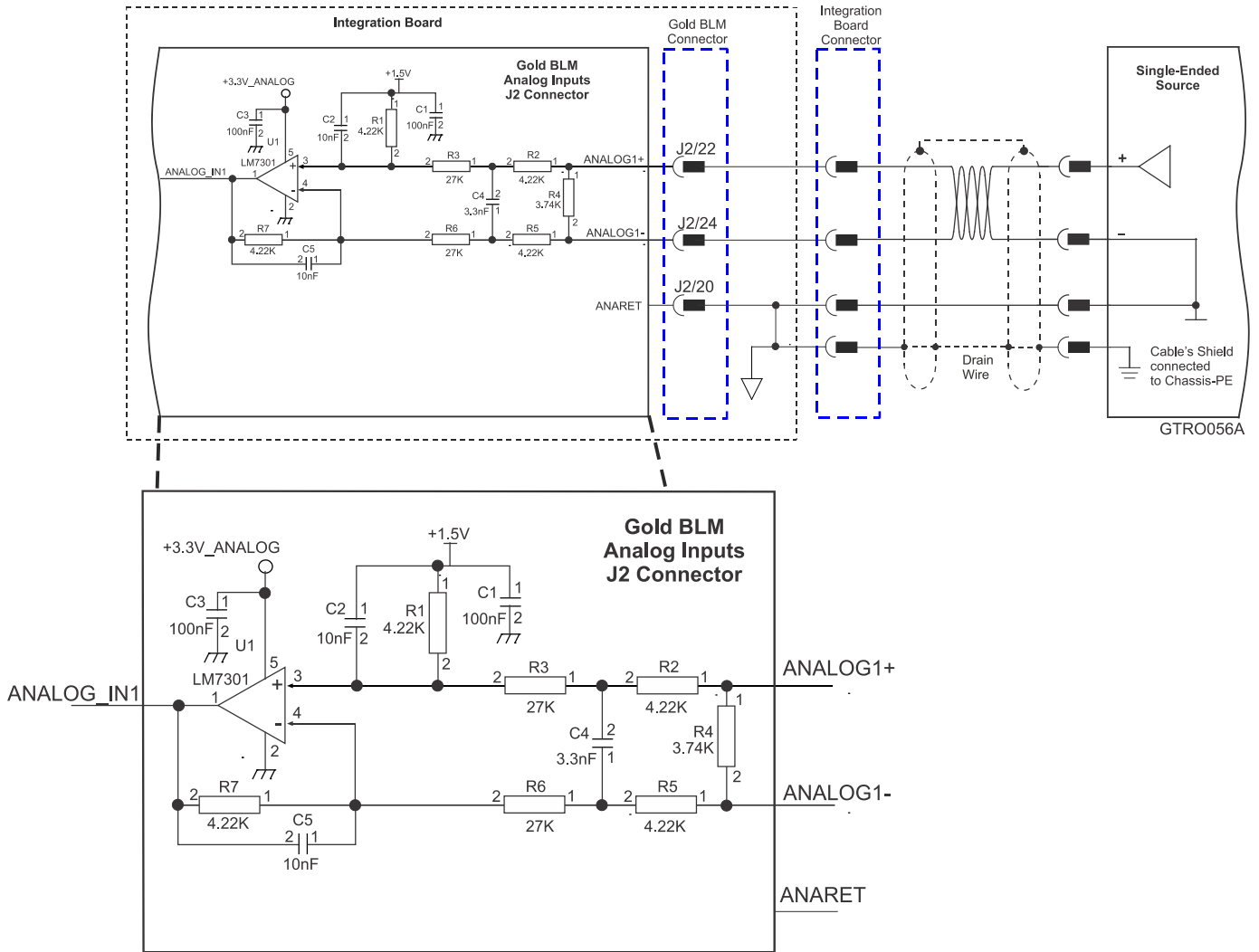

Figure 23: Analog Input with Differential ± 10 V



9.6.4.2. Analog Input 2

The Gold Trombone allows an additional single ended Analog input. Figure 24 describes the input interface of the Analog_input2 in the Gold Trombone. It also describes implementation examples for a differential analog input of 10V:

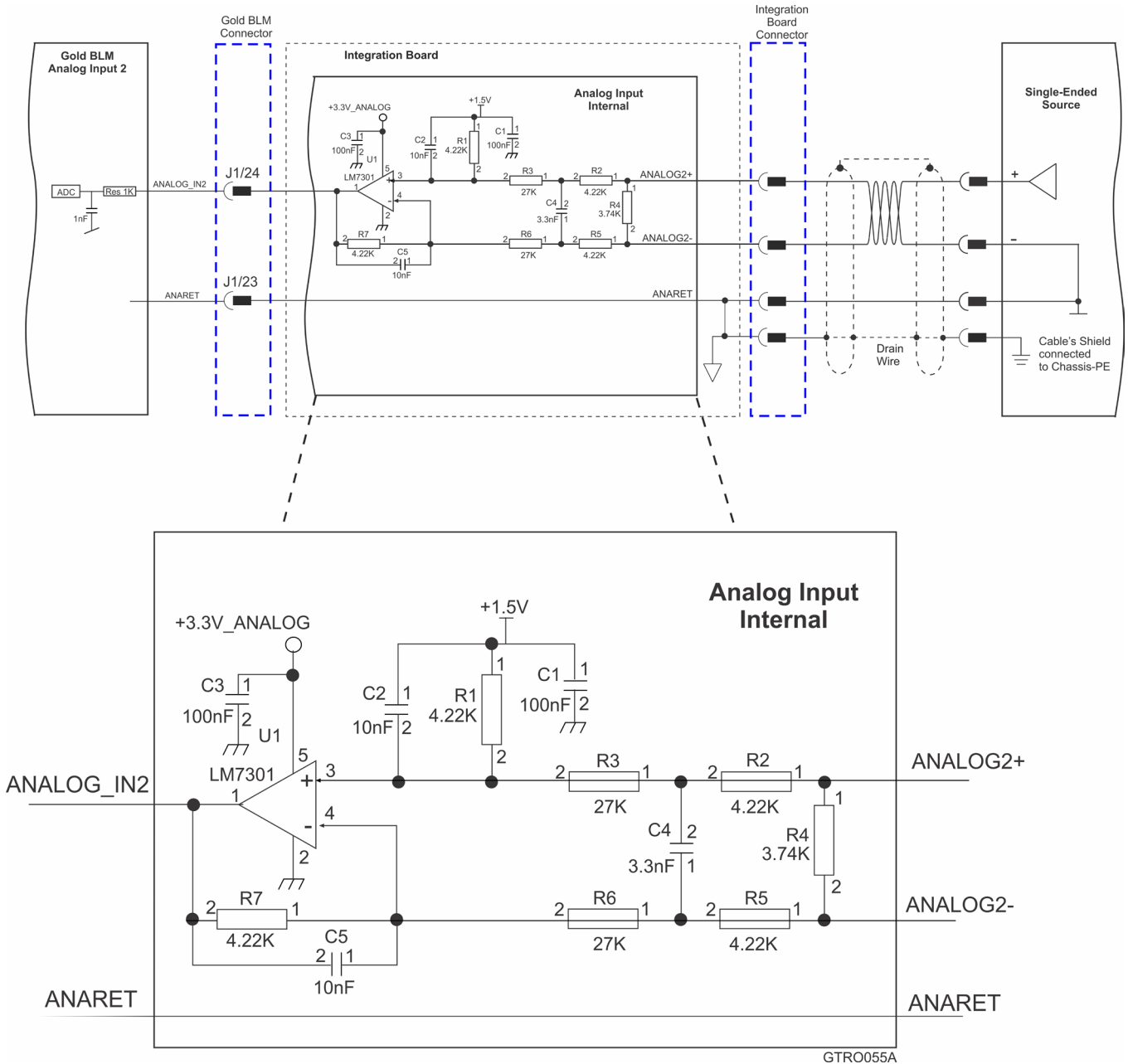

Figure 24: Analog Input 2 Example



9.6.5. RS232 TTL Logic Level

Figure 25 describes the standard RS232 connection diagram.

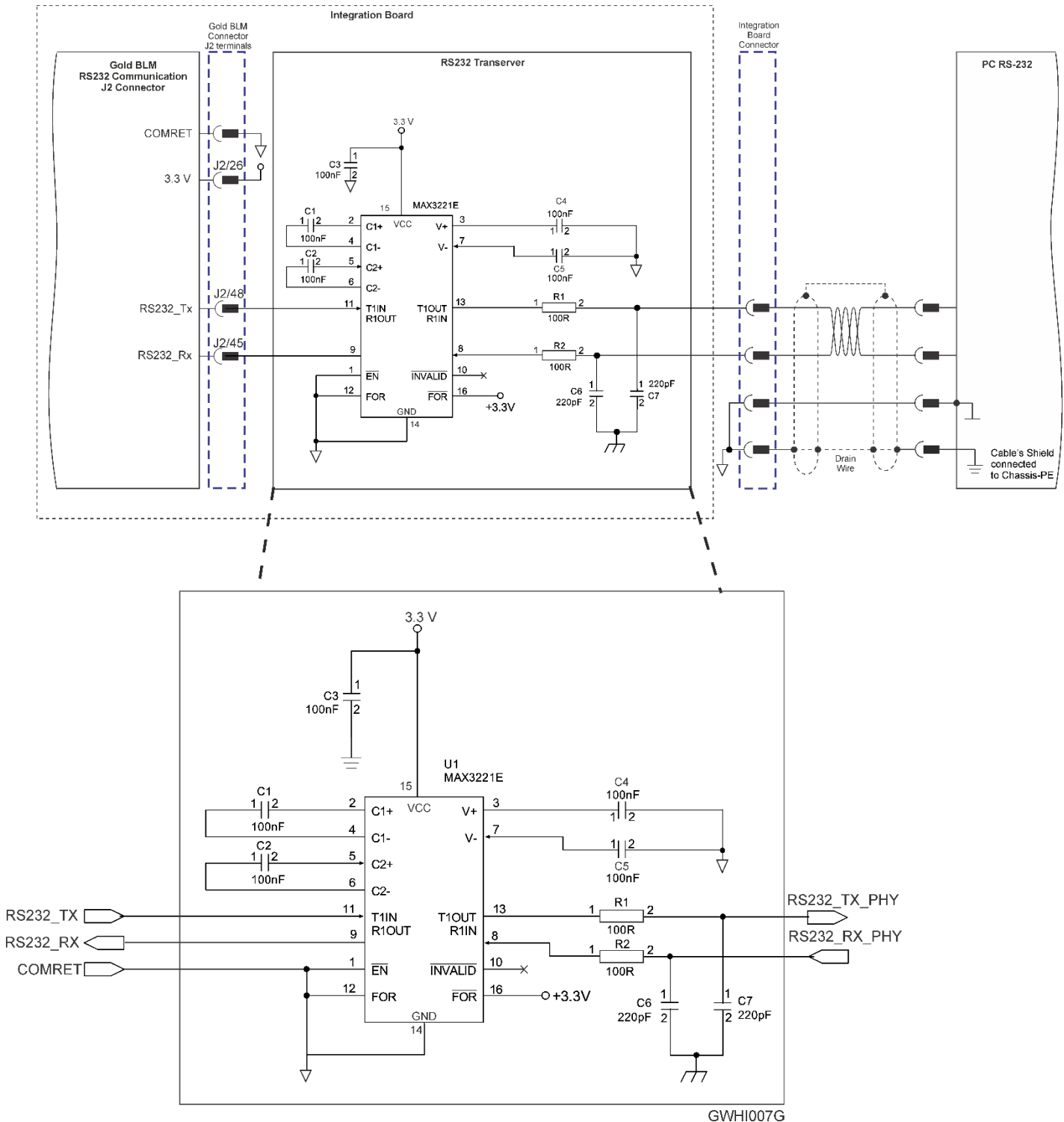

Figure 25: Standard RS232 Voltage Level incorporating RS232 TX/RX Transceiver Connection Diagram



9.6.6. USB 2.0

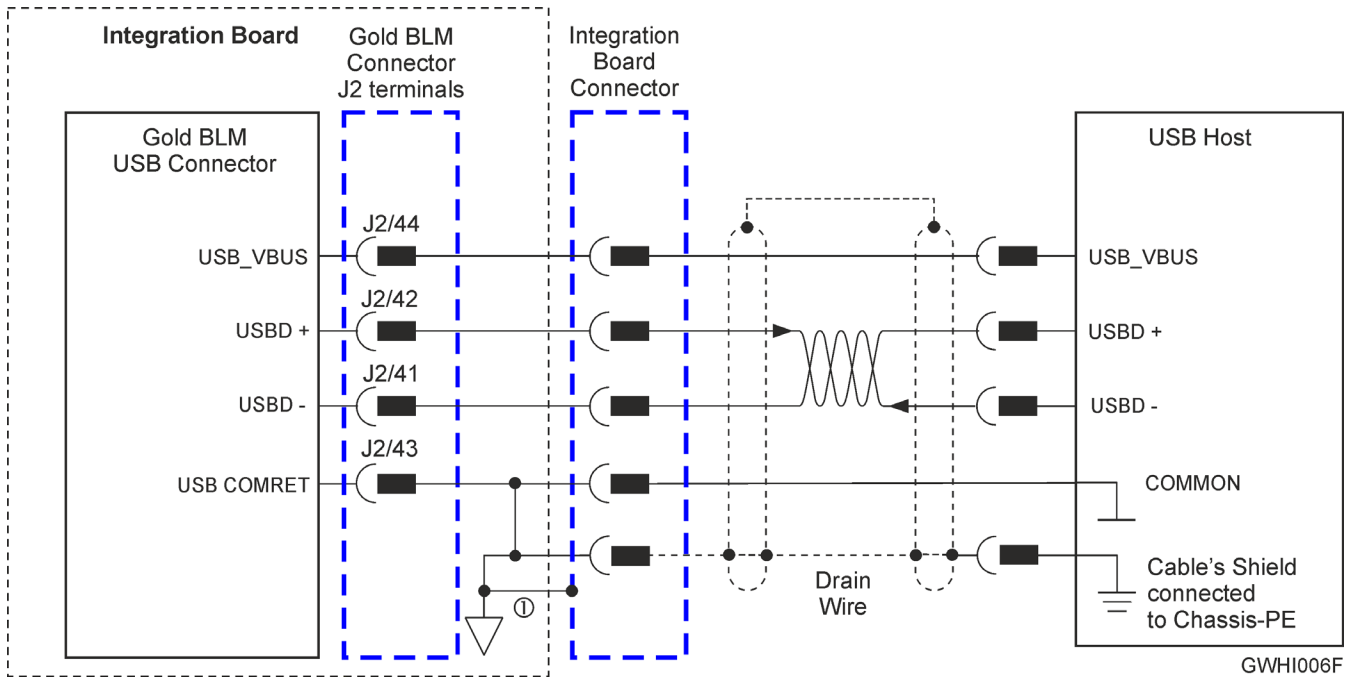

Figure 26: USB Network Diagram

Note ①: In the Gold Trombone the shield of the USB connector should be connected to the COMRET and not the PE.



9.6.7. EtherCAT/Ethernet

The Gold Trombone serves as an EtherCAT slave device, therefore it includes EtherCAT_IN and EtherCAT_OUT ports. It also includes LED indicators. The EtherCAT_IN port can be configured to an Ethernet port.

The following figure describes EtherCAT connection with a standard RJ-45 connector that includes transformer isolation.

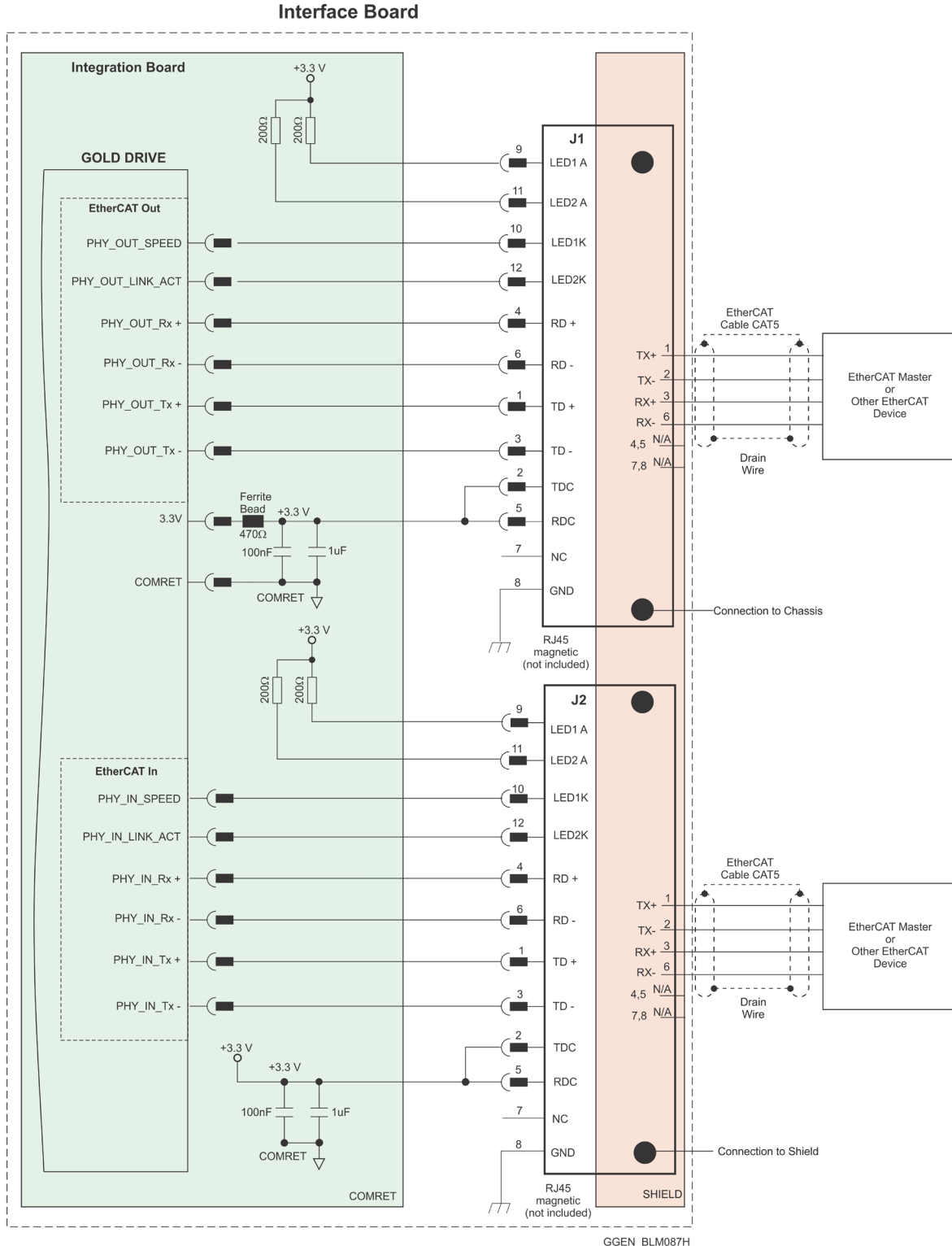
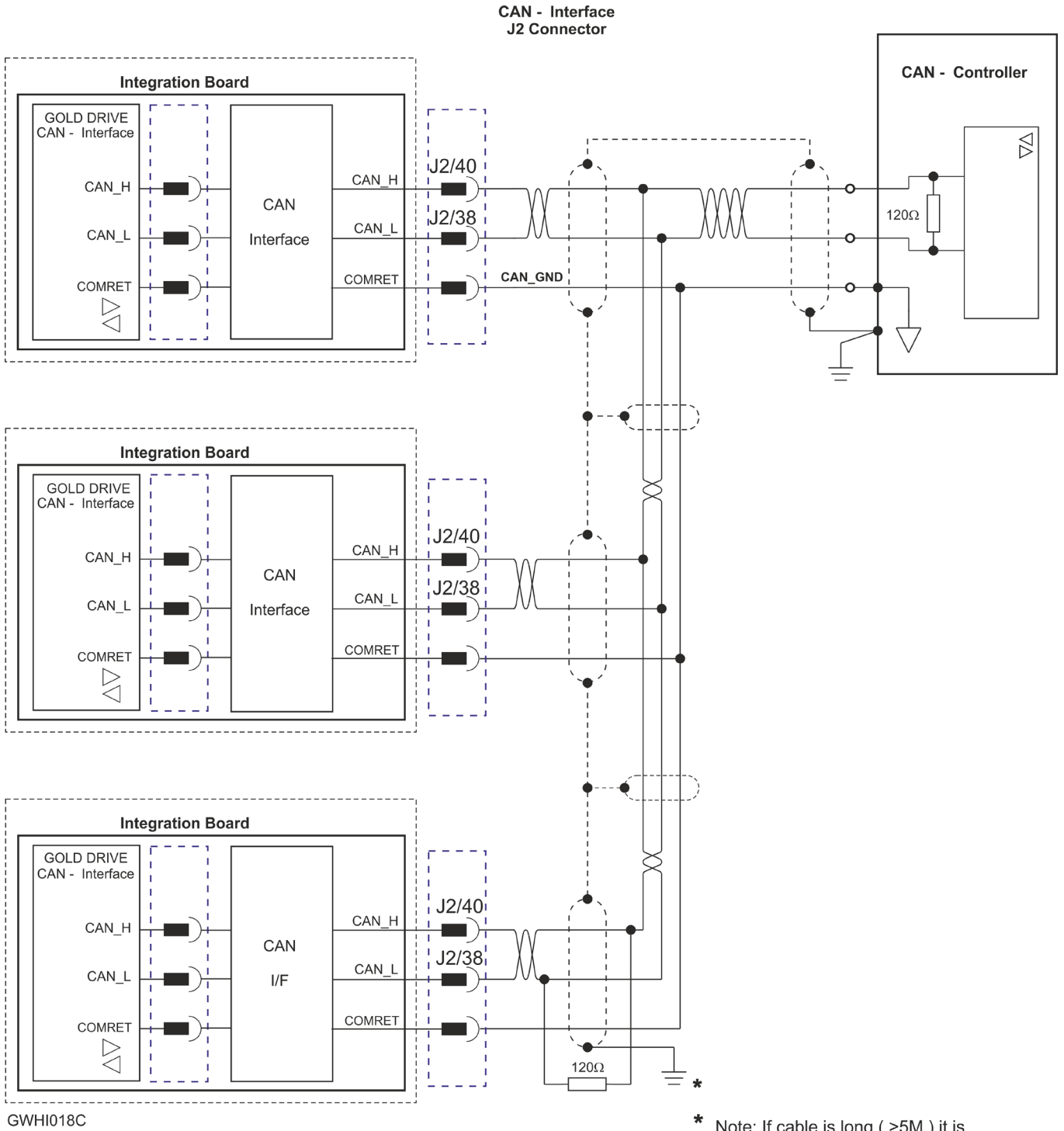

Figure 27: EtherCAT Connection Schematic with Diagram Sign of 3.3V



9.6.8. CAN

Figure 28 displays the CAN connectivity.



GWHI018C

* Note: If cable is long (>5M) it is recommended to ground at both ends

Figure 28: CANbus Connections

Important:

A 120 Ω termination resistor should be connected at each end of the network cable.



9.7. Connector J1 - Digital I/O, Analog Inputs, LEDs and STO

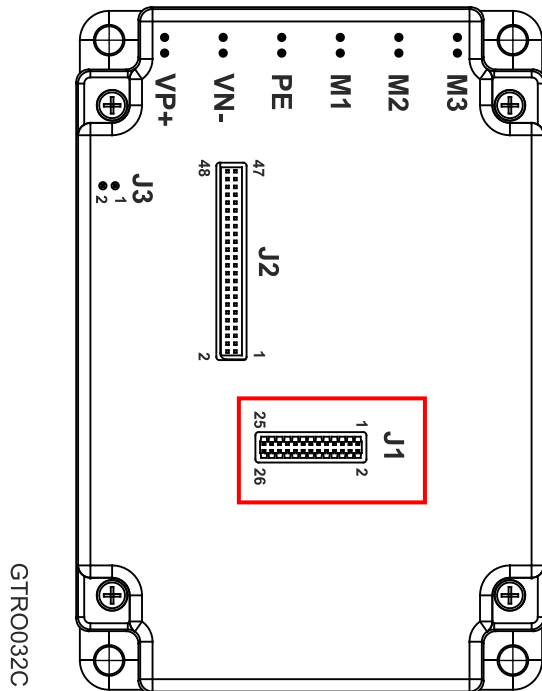

For full details on Digital and Analog I/Os, see Chapter 11 and 12 in the MAN-G-Board Level Modules Hardware Manual.

For full details on the LEDs, see Chapter 7 Drive Status Indicator, and section 14.2.6 EtherCAT Status Indicator in the in the MAN-G-Board Level Modules Hardware manual for full details.

For full details on STO, see Chapter 9 in the in the MAN-G-Board Level Modules Hardware manual for full details.

Connector Type: 1.27 mm pitch 0.41 mm sq

Pin (J1)	Signal	Function
1	COMRET	Common Return
2	+5VE	Encoder +5V supply
3	SB_Load	Serial Bus Load for extended IO (refer to MAN-G-Board Level Modules Hardware manual)
4	SB_Clock	Serial Bus_Clock (9.375Mhz) for extended IO (refer to MAN-G-Board Level Modules Hardware manual)
5	INRET1_6	Programmable digital inputs 1–6 return
6	IN1	Programmable digital input 1
7	IN2	Programmable digital input 2
8	IN3	Programmable digital input 3
9	IN4	Programmable digital input 4
10	IN5	Programmable digital input 5
11	IN6	Programmable digital input 6
12	STO_RET	Safety signal return
13	STO2	Safety 2 input (default 24 V)
14	STO1	Safety 1 input (default 24 V)
15	LED_ETHERCAT ERR	LED Status EtherCAT ERR (Cathode)



Pin (J1)	Signal	Function
16	LED_ETHERCAT RUN	LED Status EtherCAT RUN (Cathode)
17	LED2	Bi-color indication output 2 (Cathode)
18	LED1	Bi-color indication output 1 (Cathode)
19	COMRET	Common return
20	ANALOG_IN2	Analog input 2
21	OUT2	Programmable output 2
22	OUT1	Programmable output 1
23	OUT4	Programmable output 4
24	OUT3	Programmable output 3
25	VDDRET	VDD Supply Return
26	VDD	VDD Supply (5V up to 30V)

Table 6: Connector J1 Table Pinouts



9.7.1. Digital Inputs

9.7.1.1. TTL voltage level

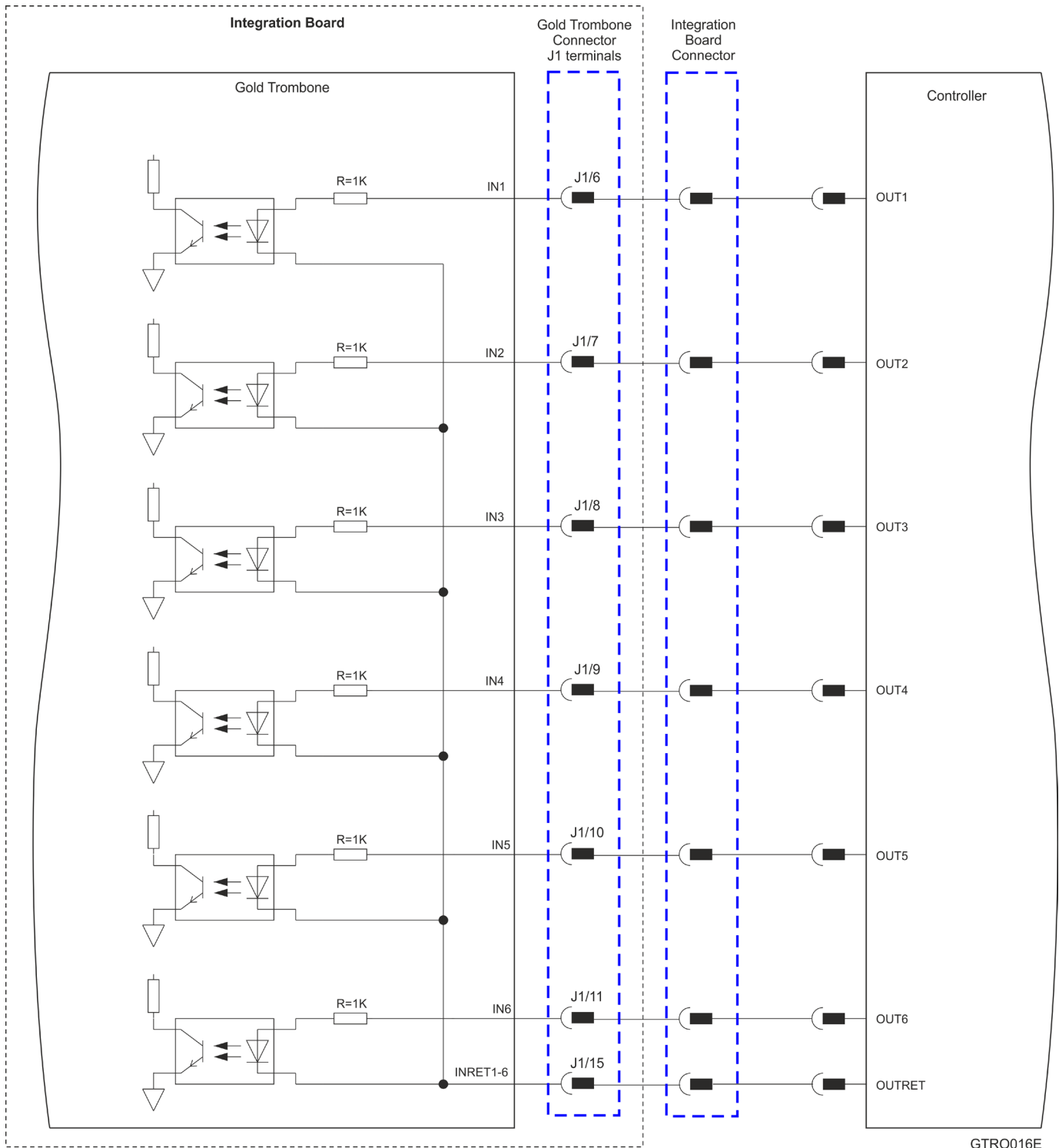

Figure 29: Digital Input TTL Mode Connection Diagram



9.7.1.2. PLC Voltage Level

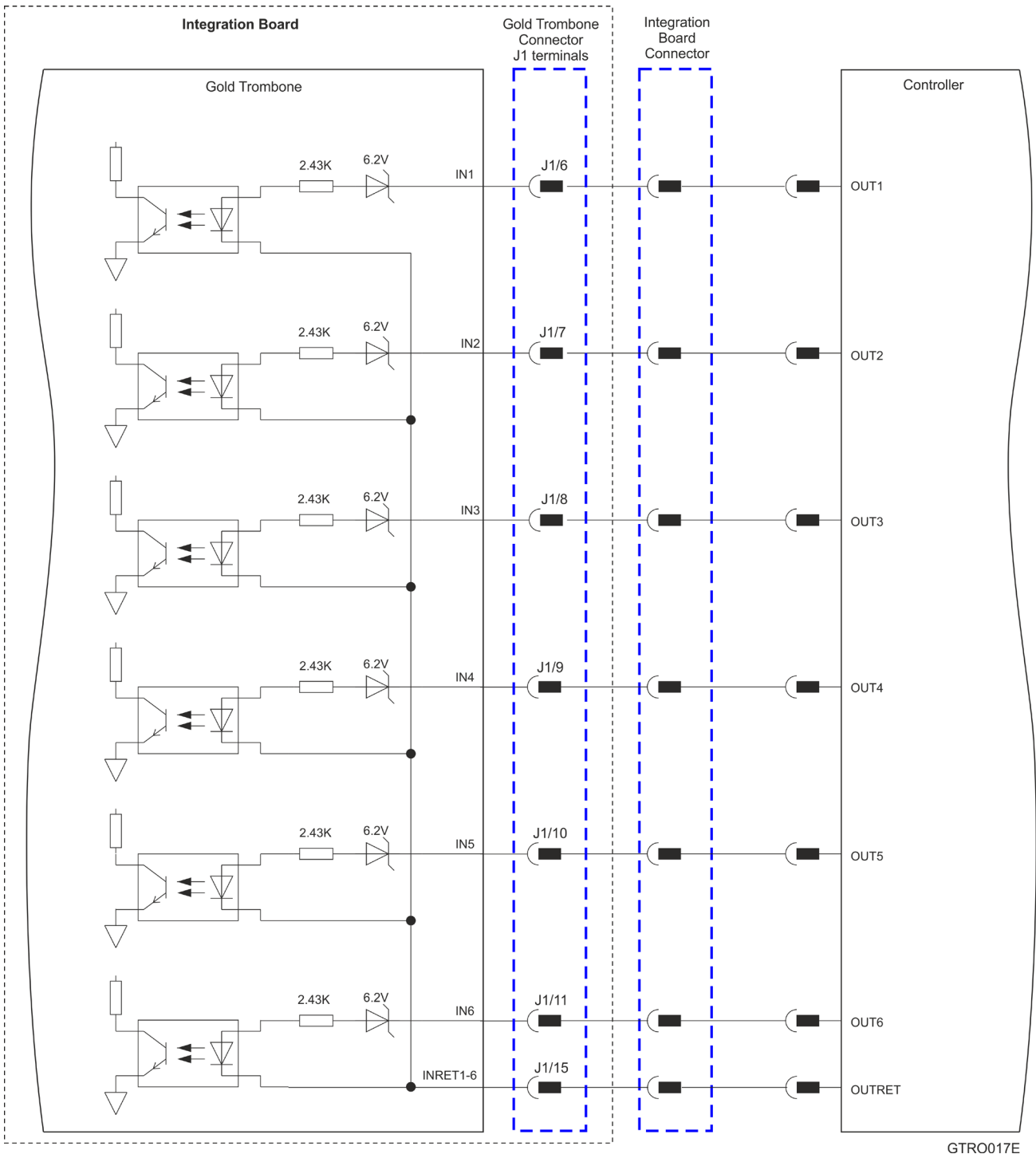

Figure 30: Digital Input PLC Mode Connection Diagram



9.7.2. Digital Outputs

9.7.2.1. TTL voltage level

The following diagram describes the TTL voltage level outputs:

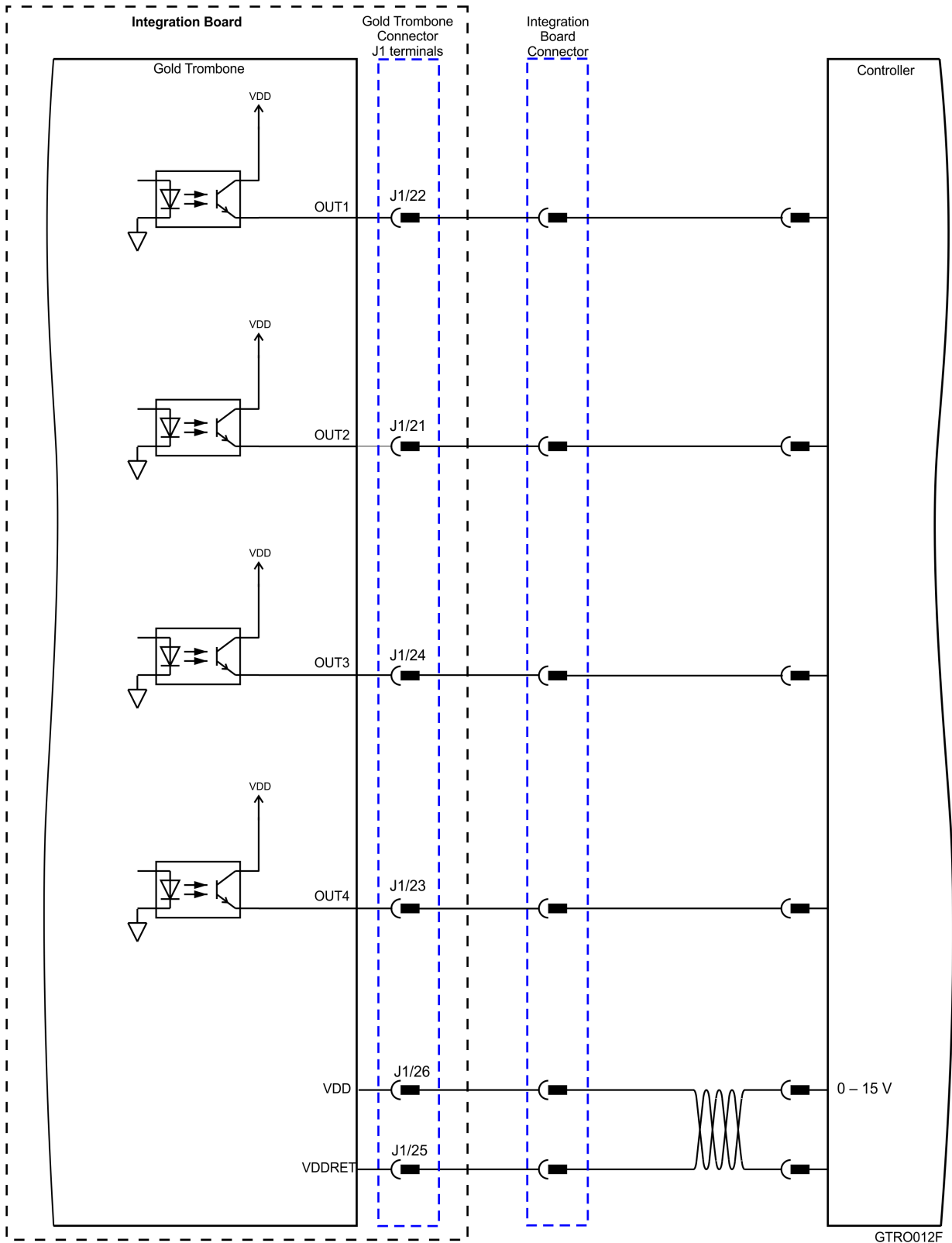

Figure 31: TTL Digital Output Connection Diagram for T or 1 Suffixes



9.7.2.2. PLC voltage level

The following diagram describes the PLC voltage level outputs:

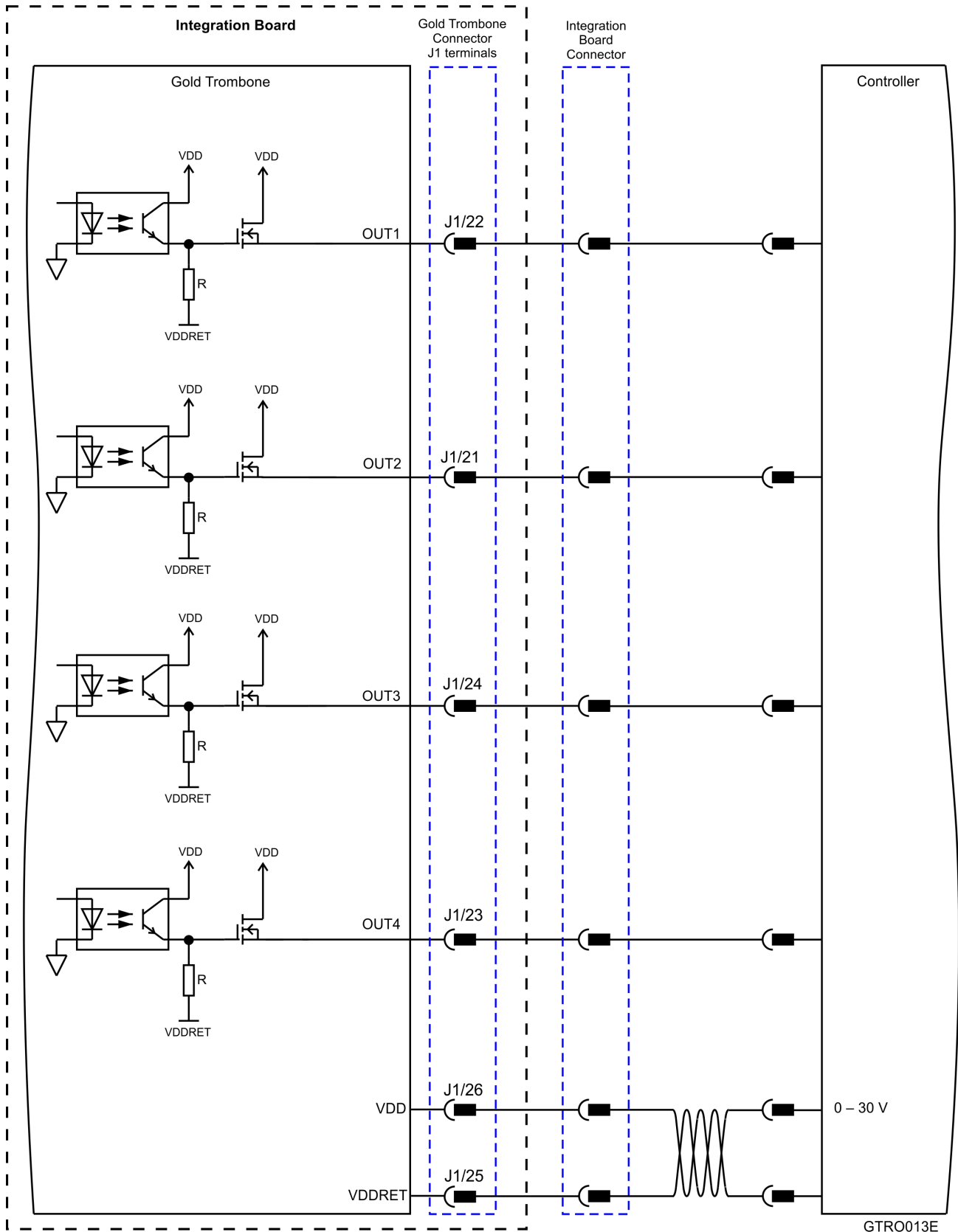

Figure 32: PLC Digital Output Connection Diagram For S or O Suffixes



9.7.3. Analog Inputs

For details of the Analog Input 2 – Single ended using Connector J1 in the Gold Trombone, refer to the section 9.6.4 Analog Inputs for details.

9.7.4. STO Input Interfaces

9.7.4.1. TTL Mode

The diagram below describes the TTL option connection for the STO input interfaces.

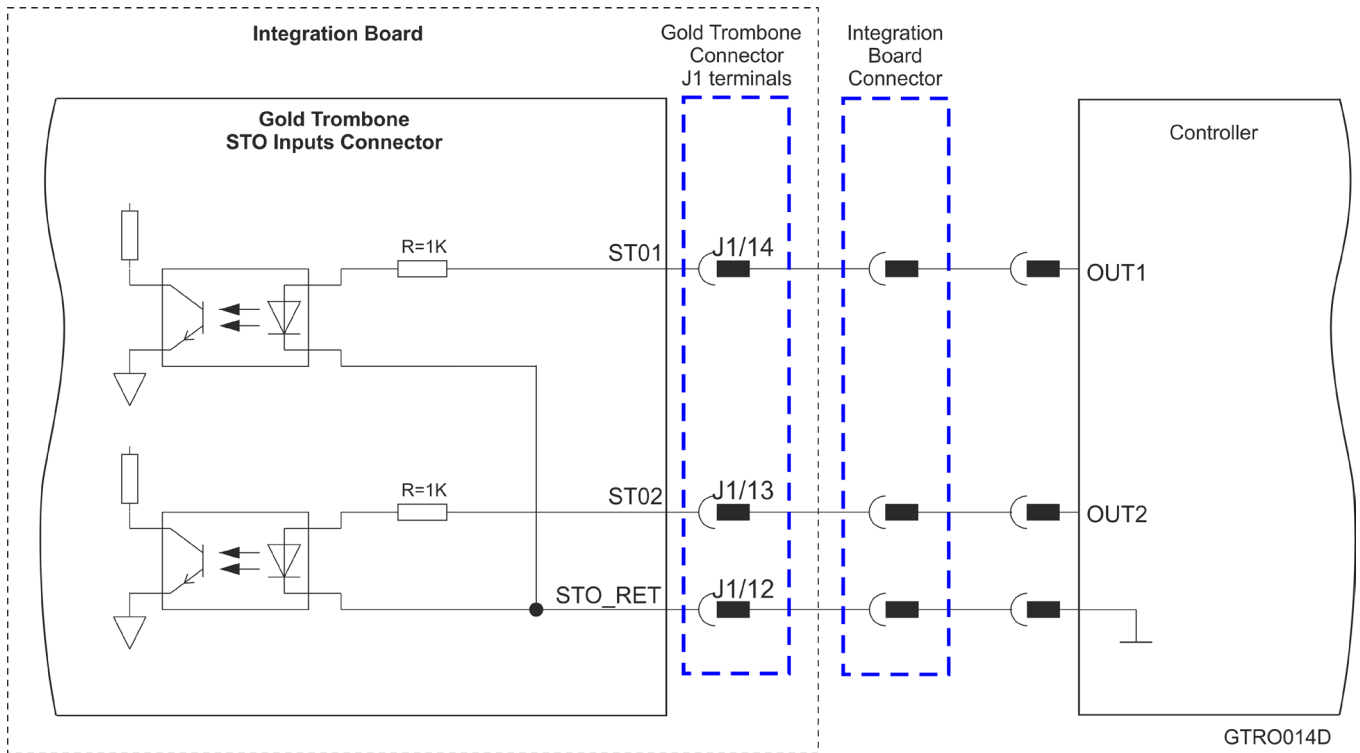

Figure 33: STO Input Connection – TTL Option for T or 1 Suffixes



9.7.4.2. PLC Source

The diagram below describes the PLC Source option connection for the STO input interfaces.

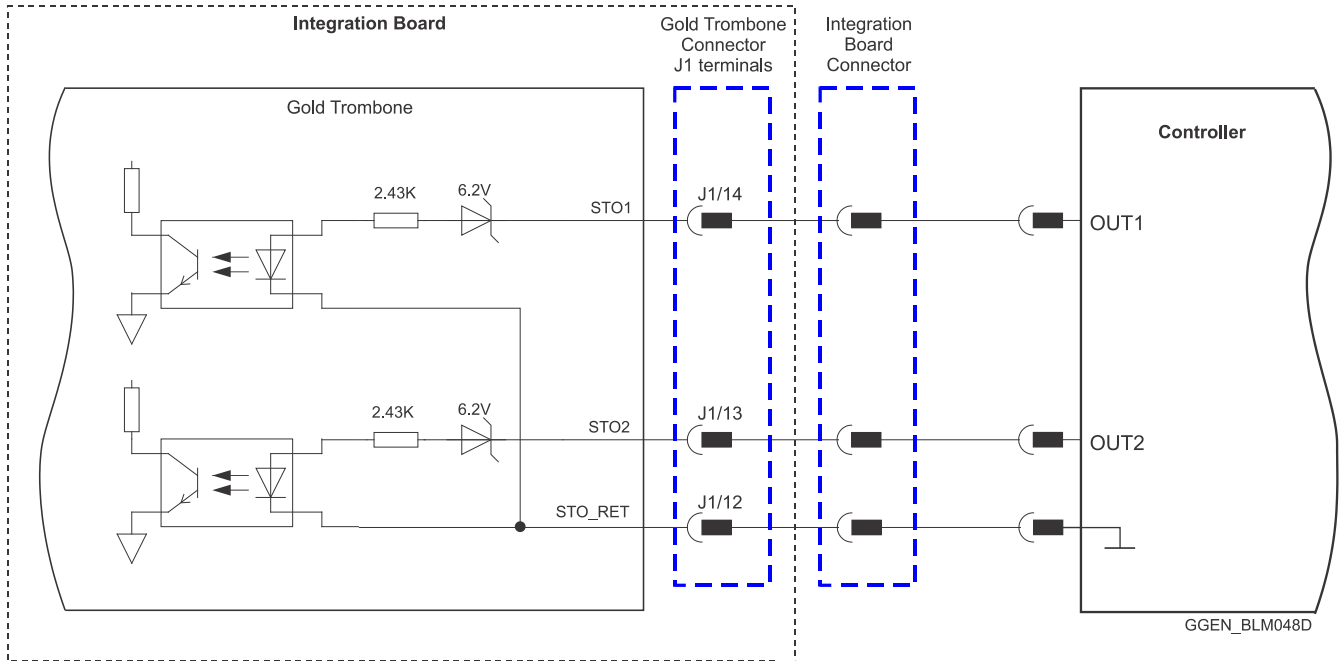

Figure 34: STO Input Connection – PLC Option for S or O Suffixes

9.7.5. EtherCAT Status Indicator

For details of the EtherCAT Status Indicator, refer to the section 14.2.6 EtherCAT Status Indicator in the in the MAN G Board Level Modules Hardware manual for full details.



Chapter 10: Powering Up

After the Gold Trombone is connected to its device, it is ready to be powered up.



Caution:

Before applying power, ensure that the DC supply is within the specified range and that the proper plus-minus connections are in order.

10.1. Initializing the System

After the Gold Trombone has been connected and mounted, the system must be set up and initialized. This is accomplished using the *EASII*, Elmo's Windows-based software application. Install the application and then perform setup and initialization according to the directions in the *EASII User Manual*.



Chapter 11: Heat Dissipation

The best way to dissipate heat from the Gold Trombone is to mount it so that its heat-sink faces up. For best results leave approximately 10 mm of space between the Gold Trombone's heat-sink and any other assembly.

11.1. Gold Trombone Thermal Data

- Heat dissipation capability (θ): approximately 5.5 °C/W
- Thermal time constant: approximately 600 seconds (thermal time constant means that the Gold Trombone will reach 2/3 of its final temperature after 10 minutes)
- Shut-off temperature: 86 °C to 88 °C (measured on the heat-sink)

11.2. Heat Dissipation Data

Heat Dissipation is shown graphically below:

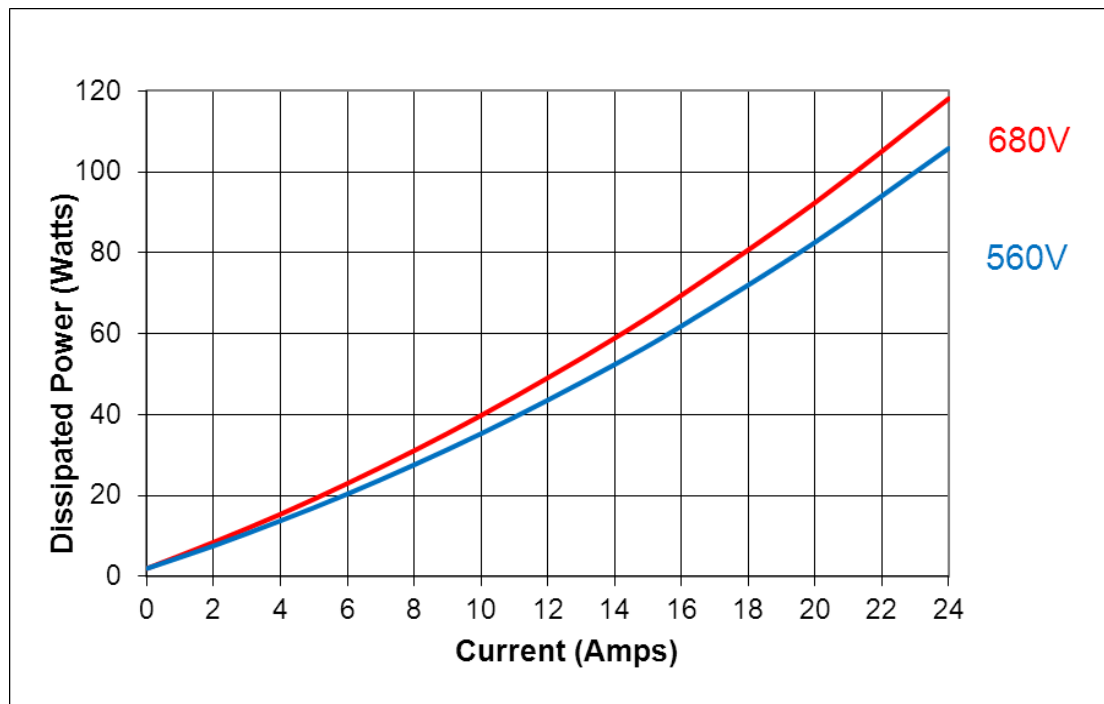

Figure 35: Dissipation versus Current Graph for 560 and 680 VDC

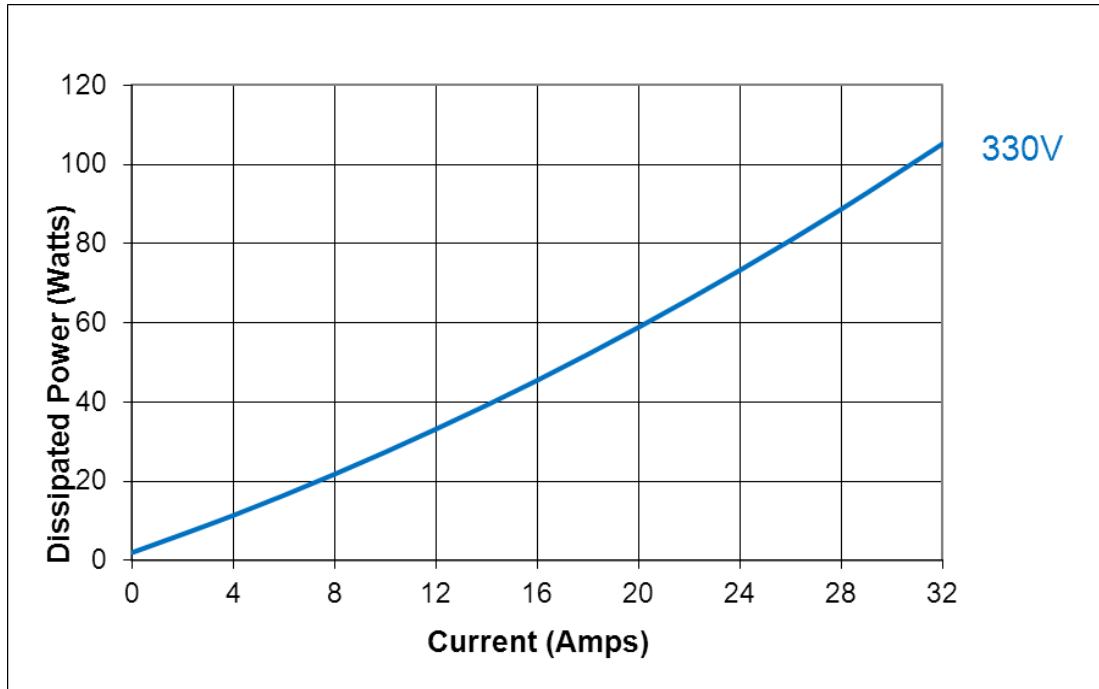

Figure 36: Dissipation versus Current Graph for 330 VDC

11.3. How to Use the Charts

The charts above are based upon theoretical worst-case conditions. Actual test results show 30% to 50% better power dissipation.

To determine if your application needs a heat sink:

1. Allow maximum heat sink temperature to be 80 °C or less (shunt down is 6 °C to 8 °C higher).
2. Determine the ambient operating temperature of the Gold Trombone as ≤ 40 °C.
3. Calculate the allowable temperature increase according to the following example: For an ambient temperature of 40 °C, $\Delta T = 80$ to 40°C = 40°C
4. Use the chart to find the actual dissipation power of the drive. Follow the voltage curve to the desired output current and then find the dissipated power.



Chapter 12: Dimensions

This chapter provides detailed technical information regarding the Gold Trombone.

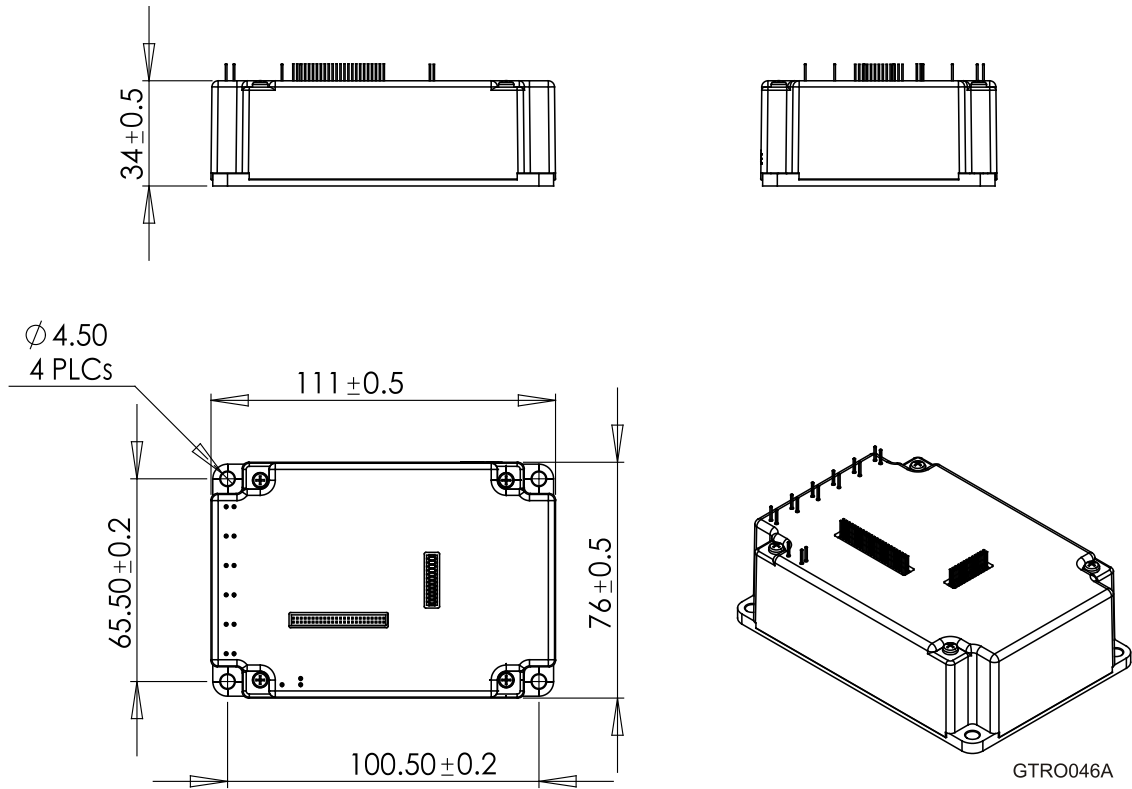



Inspiring Motion

Since 1988

For a list of Elmo's branches, and your local area office, refer to the Elmo site www.elmomc.com

